

Reproducible



Gospel Light's
KIDS@TIME

PARABLE QUEST

13 TRANSFORMING STORIES JESUS TOLD

This 13-Session Course Is Perfect for:

- Small and Large Churches • Summer Children's Programming
- Preschool and Elementary Children, Ages 3 to 12

 **Gospel Light**



GUIDELINES FOR PHOTOCOPYING

Permission to make photocopies of or to reproduce by any other mechanical or electronic means in whole or in part any page, illustration or activity in this product is granted only to the original purchaser and is intended for noncommercial use within a church or other Christian organization. None of the material in this product may be reproduced for any commercial promotion, advertising or sale of a product or service to any other persons, churches or organizations. Sharing of the material in this product with other churches or organizations not owned or controlled by the original purchaser is also prohibited. All rights reserved.

EDITORIAL STAFF

Senior Managing Editor, Sheryl Haystead • **Senior Editor**, Mary Gross Davis • **Editorial Team**, Debbie Barber, Janis Halverson, Lisa Key • **Designer**, Annette M. Chavez

Founder, Dr. Henrietta Mears • **Publisher**, William T. Greig • **Senior Consulting Publisher**, Dr. Elmer L. Towns • **Senior Editor, Theology and Biblical Content**, Dr. Gary S. Greig

Scripture quotations are taken from the *Holy Bible, New International Version*®. Copyright © 1973, 1978, 1984 by International Bible Society. Used by permission of Zondervan Publishing House. All rights reserved.

© 2010 Gospel Light, Ventura, CA 93006. All rights reserved. Printed in the U.S.A.

HOW TO USE THIS GUIDE

**IF YOU ARE A TEACHER OR A SMALL-GROUP LEADER,
FOLLOW THESE SIMPLE STEPS TO LEAD YOUR CLASS IN
AN EXPLORATION OF JESUS' PARABLES AND BIBLE VERSES
THAT CAN MAKE A DIFFERENCE IN THEIR LIVES.**

1. Read "Parable Quest Overview" on pages 9-10 and the "Parable Quest Scope and Sequence" on page 11 to get an understanding of the purpose and goals of this curriculum.
2. Look at "Advice and Answers for Schedule Planning" on pages 14-18, choose the schedule that best fits your situation and decide which centers you will include.
3. Read the teaching tips articles (pp. 34-42) for each center you will lead, taking note of the ways you can make each center an effective learning experience for the kids in your group.



**IF YOU ARE THE CHILDREN'S DIRECTOR
OR COORDINATOR OF PARABLE QUEST,
FOLLOW THE ABOVE STEPS AND ADD A FEW MORE!**

1. Pay special attention to "Getting and Keeping the Very Best Staff" on pages 19-21. Remember to start recruiting early—several months before *Parable Quest* begins.
2. Read "Outreach Ideas," "Partnering with Parents," "Decorating Ideas" and "Theme Ideas" on pages 26-33 for exciting ideas to motivate interest in *Parable Quest*, special ways to involve parents, eye-catching decorating ideas and more!
3. Print and photocopy the materials you need for each session and distribute to small-group leaders or teachers, or e-mail the lessons to them.



**Combining preschoolers and elementary-age children
in one small group of children? Get advice for effective
teaching of mixed ages by reading "Teach-
ing Preschoolers and Elementary Children
Together" on pages 24-25.**



CONTENTS

How to Use This Guide 3

COORDINATOR INFORMATION 7

This section contains practical information that can help you plan and lead the *Parable Quest* program.

Parable Quest Overview 9

Parable Quest Scope and Sequence 11

Leading a Child to Christ 12

Advice and Answers for Schedule Planning 14

Getting and Keeping the Very Best Staff 19

Publicity Guidelines and Schedule 22

Teaching Preschoolers and Elementary Children Together 24

Outreach Ideas 26

Partnering with Parents 27

Decorating Ideas 29

Theme Ideas 33

Bible Story Center Tips 34

Art Center Tips 36

Game Center Tips 37

Coloring/Puzzle Center Tips 39

Worship Center Tips 40

PARABLE QUEST LESSONS 43

In this section are 13 lessons to help your students learn about Jesus' parables and how God's Word can make a difference in their lives.

Lesson 1 Lost Coin 45

Lesson 2 Salt and Light 59

Lesson 3 Wise and Foolish Builders 73

Lesson 4 Sower 87

Lesson 5 Lost Sheep 101

Lesson 6 Unforgiving Servant 115

Lesson 7 Good Samaritan 129

Lesson 8 Persistent Friend 143

Lesson 9 Rich Fool 157

Lesson 10 Great Banquet	171
Lesson 11 Prodigal Son.....	185
Lesson 12 Pharisee and Tax Collector	199
Lesson 13 Talents	213

RESOURCES **227**

This section includes helpful resources that you can customize for use in your church.

Certificates	229
Family Talk.....	231
Parent Letters.....	232
Patterns.....	234
Planning Page.....	238
Publicity Flyers.....	239
Puzzle Answers	242
Song Charts	246

CD-ROM

On the CD-ROM you will find all the music for *Parable Quest*, and valuable resources such as modifiable flyers, lessons ready to e-mail, Bible story posters and rainforest sound effects.





COORDINATOR INFORMATION

This section contains concise and practical information that can help you plan and lead the *Parable Quest* program. Included in this section is an overview of the course, the scope and sequence, guidelines for recruiting, publicity suggestions, as well as tips for each of the activity centers in this program.

PARABLE QUEST OVERVIEW

Welcome to *Parable Quest*, a 13-lesson adventure for children ages 3-12. The fun and excitement of exploring the Amazon rainforest is combined with the discovery of what it means to follow Jesus on a life-changing adventure.

THE PURPOSE AND GOALS

The purpose of *Parable Quest* is to introduce children to 13 parables that Jesus told. Through these parables children will build a growing relationship with Jesus and discover how God's Word can make a difference in their lives every day. The everyday objects and real-life situations that Jesus described in His parables help children understand the principles of the Bible. This course is designed to not only give both preschool- and elementary-age children a knowledge of God's Word, but also the opportunity to respond to His truth by living out their Christian faith every day.

The sessions of *Parable Quest* are planned to help your team lead children in discovering 13 actions that will help them follow Jesus. Each lesson's Bible verse (simplified for preschoolers) gives a life-changing Bible command. (See p. 11 for a complete course overview.)

Thirteen significant parables told by Jesus are special features of this course. While some children may be familiar with the story action of the parables, they will still benefit from this course's focus on the truths of spiritual and eternal value demonstrated in each parable. For example, as children hear the truth of the Parable of the Lost Coin, they will gain a perspective on the rejoicing in heaven when they become part of God's family. From the Parable of the Wise and Foolish Builders, children will discover Jesus' way to have wisdom. And as children hear Jesus tell the Parable of the Pharisee and Tax Collector, they will realize the importance of being humble and showing respect to others.

In *Parable Quest* lessons, your children will be inspired to deepen and enrich not only their knowledge of God's Word, but also their understanding of living as a follower of Jesus every day.

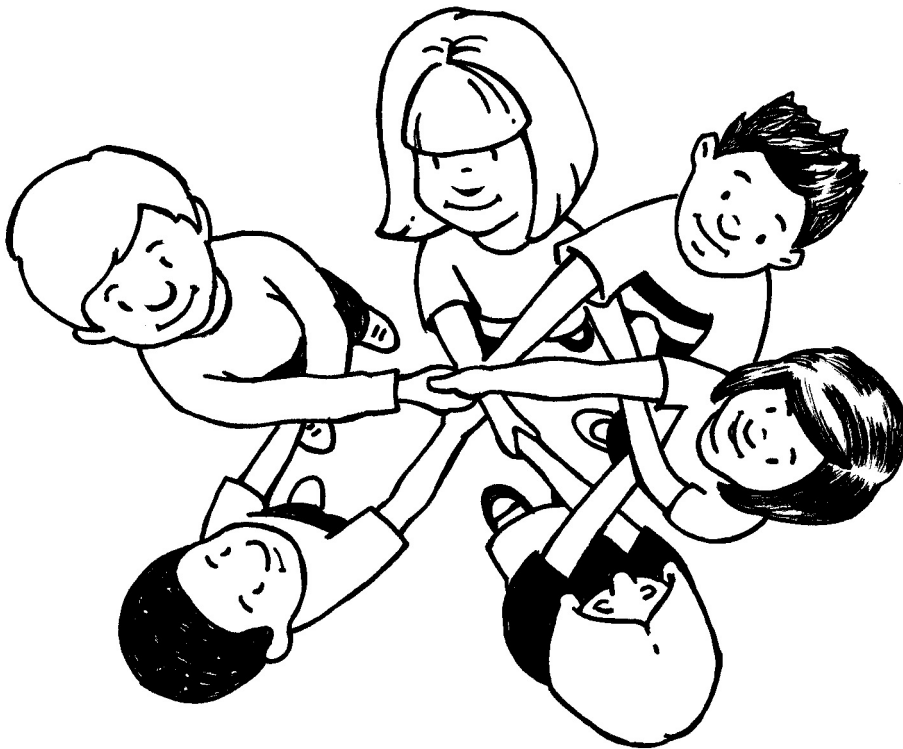

SPECIAL FEATURES

- Each Bible story offers creative storytelling techniques to involve children in an active way. In addition, a unique Adventure Box in each lesson suggests an item the teacher can use to help children visualize and understand the parable featured in the lesson. (See pp. 34-35 for a list of these items.)
- Because children learn in diverse ways, *Parable Quest* is filled with a variety of activities that appeal to children's many learning styles. In each lesson, the children may participate in active games and creative art activities that will help them express what they are learning.
- The Worship Center provides ideas for worship and prayer as well as lively, kid-appealing games and songs.
- In each lesson, Bonus Theme Ideas are suggested to help create even more rainforest excitement for your students and leaders—and to keep attendance and enthusiasm high. You'll find a variety of creative ideas such as fun rainforest science activities, decorating hints and snacks.
- Get a quick overview of each lesson's activities by referring to the Planning Page. This page also functions as a convenient supply list to aid in quickly collecting the materials your leaders and teachers need.
- *Parable Quest* CD-ROM provides each lesson ready to e-mail to teachers or to print out and make as many copies as you need. Also, the CD-ROM offers fresh and fun music that will keep your kids singing all week long about the life-changing adventure we can experience as we follow Jesus. Make a copy for every child to take home!

Best of all, you'll appreciate the flexibility of this course! Every church and every group of children is different. Whether you are a large church with separate groups for each age level or a small church that combines preschoolers and elementary-age children together in one group, this curriculum easily adapts to meet your needs. The activity and schedule choices provide you with the opportunity to customize each lesson to fit you and your church. You'll love the wealth of ideas that will help your team involve children and build relationships with them. *Parable Quest* takes you beyond just leading kids in fun activities as you guide them in spiritual growth.



	LESSON TITLE	LIFE FOCUS	BIBLE STORY	MEMORY VERSE	PRESCHOOL ADAPTATION
1	BELIEVE IN JESUS	When you believe in Jesus and become a part of God's family, everyone in heaven rejoices.	Lost Coin • Luke 15:8-10	"To all who received him, to those who believed in his name, he gave the right to become children of God." John 1:12	"Believe in Jesus and you will be God's child."
2	SHINE YOUR LIGHT	Our everyday actions of love and obedience to God show others who God is.	Salt and Light • Matthew 5:13-16	"Let your light shine before men, that they may see your good deeds and praise your Father in heaven." Matthew 5:16	"Do good things to show God's love."
3	OBEY THE WORD	The way to have wisdom and confidence is to obey God's commands.	Wise and Foolish Builders • Matthew 7:24-27	"Do not merely listen to the word, and so deceive yourselves. Do what it says." James 1:22	"Obey God's Word."
4	GROW IN GOD'S WAYS	Growing as followers of God begins when we love and obey God's Word.	Sower • Matthew 13:1-23; Mark 4:1-20; Luke 8:4-15	"Live a life worthy of the Lord and . . . please him in every way: bearing fruit in every good work, growing in the knowledge of God." Colossians 1:10	"Please God by doing good things and getting to know who God is."
5	DEPEND ON GOD'S LOVE	Nothing we do can change God's generous love for us.	Lost Sheep • Matthew 18:12-14; Luke 15:3-7	"I pray that you, being rooted and established in love, may have power, together with all the saints, to grasp how wide and long and high and deep is the love of Christ." Ephesians 3:17-18	"Discover how wide and deep is the love of Christ."
6	SHOW MERCY	Because there is no limit to God's forgiveness for us, we can always show His mercy to others.	Unforgiving Servant • Matthew 18:21-35	"Be kind and compassionate to one another, forgiving each other, just as in Christ God forgave you." Ephesians 4:32	"Be kind and forgive each other."
7	LOVE IN ACTION	Showing God's love means we do more than just talk about caring for others: we put our words into action.	Good Samaritan • Luke 10:25-37	"Let us not love with words or tongue but with actions and in truth." 1 John 3:18	"Love others with actions, not just words."
8	NEVER GIVE UP PRAYING	Never give up praying, because God promises to hear and answer our prayers.	Persistent Friend • Luke 11:1-13	"Call upon me and come and pray to me, and I will listen to you." Jeremiah 29:12	"Pray to God and He will hear you."
9	GET TO KNOW GOD	When we love God more than anything, we spend our time getting to know Him.	Rich Fool • Luke 12:16-21	"I seek you with all my heart; do not let me stray from your commands." Psalm 119:10	"I love you with all my heart. Help me obey you."
10	SAY "YES" TO GOD	Be ready to say "yes" to God's invitation so that you can enjoy life with Him now and forever.	Great Banquet • Luke 14:16-24	"Here I am! I stand at the door and knock. If anyone hears my voice and opens the door, I will come in and eat with him, and he with me." Revelation 3:20	"Jesus says, 'Listen! When you hear about my love for you, be my friend.'"
11	ASK FORGIVENESS	When we've disobeyed God, if we ask for forgiveness, God's constant love is shown by His forgiveness.	Prodigal Son • Luke 15:11-32	"If we confess our sins, he is faithful and just and will forgive us our sins and purify us from all unrighteousness." 1 John 1:9	"If we tell God we are sorry for our sin, He will forgive us."
12	BE HUMBLE	Show respect to others and be humble and patient in the way you treat them because God values each person.	Pharisee and Tax Collector • Luke 18:9-14	"Be completely humble and gentle; be patient, bearing with one another in love." Ephesians 4:2	"Be patient and show love to each other."
13	USE YOUR GIFTS	God created us as unique people who can use His gifts to serve others.	Talents • Matthew 25:14-30	"Each one should use whatever gift he has received to serve others." 1 Peter 4:10	"God made you and wants you to serve others."

PARABLE QUEST SCOPE AND SEQUENCE

LEADING A CHILD TO CHRIST

Many adult Christians look back to their childhood years as the time when they accepted Christ as Savior. As children mature, they will grow in their understanding of the difference between right and wrong. They will also develop a sense of their own need for forgiveness and feel a growing desire to have a personal relationship with God.

However, the younger the child is the more limited he or she will be in understanding abstract terms. Children of all ages are likely to be inconsistent in following through on their intentions and commitments. Therefore, they need thoughtful, patient guidance in coming to know Christ personally and continuing to grow in Him.

PRAY

Ask God to prepare the students in your group to receive the good news about Jesus and prepare you to communicate effectively with them.

PRESENT THE GOOD NEWS

Use words and phrases that students understand. Avoid symbolism that will confuse these literal-minded thinkers. Remember that each child's learning will be at different places on the spectrum of understanding. Discuss these points slowly enough to allow time for thinking and comprehending:

- a. God wants you to become His child. Do you know why God wants you in His family? (See 1 John 3:1.)
- b. You and I and all the people in the world have done wrong things. The Bible word for doing wrong is "sin." What do you think should happen to us when we sin? (See Romans 6:23.)
- c. God loves you so much, He sent His Son to die on the cross for your sins. Because Jesus never sinned, He is the only One who can take the punishment for your sins. On the third day after Jesus died, God brought Him back to life. (See 1 Corinthians 15:3-4; 1 John 4:14.)
- d. Are you sorry for your sins? Tell God that you are. Do you believe Jesus died to take the punishment for your sins? Tell God that, too. If you admit your sins and tell Him you do believe and accept Jesus' death to take away your sins—God forgives all your sin. (See 1 John 1:9.)
- e. The Bible says that when you believe that Jesus is God's Son and that He is alive today, you receive God's gift of eternal life. This gift makes you a child of God. This means God is with you now and forever. (See John 1:12; 3:16.)

Give students many opportunities to think about what it means to be a Christian; expose them to a variety of lessons and descriptions of the meaning of salvation to aid their understanding.

TALK PERSONALLY WITH THE STUDENT

Talking about salvation one-on-one creates the opportunity to ask and answer questions. Ask questions that move the student beyond simple yes or no answers or recitation of memorized information. Ask open-ended, what-do-you-think questions such as:

- "Why do you think it's important to . . . ?"
- "What are some things you really like about Jesus?"
- "Why do you think that Jesus had to die because of wrong things you and I have done?"
- "What difference do you think it makes for a person to be forgiven?"

When students use abstract terms or phrases they have learned previously, such as "accepting Christ into my heart," ask them to tell you what the term or phrase means in different words. Answers to these open-ended questions will help you discern how much the student does or does not understand.

OFFER OPPORTUNITIES WITHOUT PRESSURE

Children normally desire to please adults. This characteristic makes them vulnerable to being unintentionally manipulated by well-meaning adults. A good way to guard against coercing a student's response is to simply pause periodically and ask, "Would you like to hear more about this now or at another time?" Loving acceptance of the student, even when he or she is not fully interested in pursuing the matter, is crucial in building and maintaining positive attitudes toward becoming part of God's family.

GIVE TIME TO THINK AND PRAY

There is great value in encouraging a student to think and pray about what you have said before making a response. Also allow moments for quiet thinking about questions you have asked.

RESPECT THE STUDENT'S RESPONSE

Whether or not a student declares faith in Jesus Christ, there is a need for adults to accept the student's action. There is also a need to realize that a student's initial responses to Jesus are just the beginning of a lifelong process of growing in the faith.

GUIDE THE STUDENT IN FURTHER GROWTH

There are several important parts in the nurturing process.

- Talk regularly about your relationship with God. As you talk about your relationship, the student will begin to feel that it's OK to talk about such things. Then you can comfortably ask the student to share his or her thoughts and feelings, and you can encourage the student to ask questions of you.
- Prepare the student to deal with doubts. Emphasize that certainty about salvation is not dependent on our feelings or doing enough good deeds. Show the student places in God's Word that clearly declare that salvation comes by grace through faith. (See John 1:12; Ephesians 2:8-9; Hebrews 11:6; 1 John 5:11.)
- Teach the student to confess all sins. This means agreeing with God that we really have sinned. Assure the student that confession always results in forgiveness. (See 1 John 1:9.) God's forgiveness helps us want to do what's right instead of what's wrong.

THE PRESCHOOL CHILD AND SALVATION

- The young child is easily attracted to Jesus. Jesus is a warm, sympathetic person who obviously likes children, and children readily like Him. These early perceptions prepare the foundation for the child to receive Christ as Savior and to desire to follow His example in godly living. While some preschoolers may indeed pray to become a member of God's family by accepting Jesus as their Savior, expect wide variation in children's readiness for this important step. Allow the Holy Spirit room to work within His own timetable.
- Talk simply. Phrases such as "born again" or "Jesus in my heart" are symbolic and far beyond a young child's understanding. Focus on how God makes people a part of His family.
- Present the love of Jesus by both your actions and your words in order to lay a foundation for a child to receive Christ as Savior. Look for opportunities in every lesson to talk with a young child who wants to know more about Jesus.



ADVICE AND ANSWERS FOR SCHEDULE PLANNING

Begin your planning for *Parable Quest* by choosing when you will schedule the program. This 13-lesson curriculum can be used effectively for second-hour programs, midweek programs, Sunday School or summertime Sunday morning, weekday programs or home groups.

No matter when or where *Parable Quest* takes place, there are two main format options—Self-Contained Groups and the Learning Center Plan. Read the following descriptions and select the learning format that fits your needs.

SELF-CONTAINED GROUPS

If you are confined to a single room or have a small number of children, Self-Contained Groups may be your best option. In this format, groups of six to eight students are formed. Each group has a teacher who leads his or her group in the activities. (If the size of the group is larger, additional teachers or helpers are needed.)

The greatest benefit of Self-Contained Groups is that teachers are able to form meaningful relationships with the students because they remain together during the entire session.

Self-Contained Groups are often a good option for small churches.

LEARNING CENTER PLAN

The Learning Center Plan offers an exciting recruiting and schedule variation for *Parable Quest*. In this plan, each teacher prepares and leads only one activity. Guides (adults, teenagers or even responsible seventh and eighth graders) lead groups of students to rotate between the centers (Bible Story, Art, Game, etc.). In other words, each teacher leads only one part of the lesson. Each teacher's responsibility for only one center simplifies teacher preparation and often improves teaching effectiveness, as well as makes it easier to recruit teachers. The Learning Center Plan also keeps inexperienced teachers from feeling overwhelmed. Teachers who don't enjoy leading games or who are apprehensive about telling Bible stories can leave those tasks to others more skilled in those areas.

The Learning Center Plan is often a good option for medium or large churches.

If you want to combine preschool and elementary children in the same group, read "Teaching Preschoolers and Elementary Children Together" on pages 24-25.



WHAT DO STUDENTS DO AND WHO LEADS THEM?

- Students are placed in small permanent groups (six to eight children is the best size). As much as possible, form groups with children of similar ages.
- Each group has at least one guide who leads the group to various centers. (Color code name tags for easy group identification.)
- Each group, along with its guide(s), visits each center during each session. All groups participate at once in the Worship Center.

If you have large numbers of children, two groups may participate in one center at the same time.

WHAT DO TEACHERS DO?

- Each teacher takes responsibility for one center, remaining at the center and instructing each group as it visits the center. (Note: If both preschool and elementary-aged children visit the same center, teachers modify activities as shown in each lesson.)
- During the Worship Center, teachers (and guides) sit with students and participate with them in the activities.

WHAT ARE THE CENTERS?

- One room or outside area is designated for each of the *Parable Quest* learning centers. Post a large sign to identify each center.
- Decorate centers (see *Decorating Ideas* on pp. 29-32) and give centers fun names of areas that might be found in a rainforest such as the Canopy Adventure, Rainforest Trail, Toucan's Paradise, Roaring River, Jumpin' Jungle, Amazon Outpost or Rainforest Treehouse. Choose from the centers suggested in the following diagram:

WORSHIP CENTER



BIBLE STORY CENTER



ART CENTER



GAME CENTER

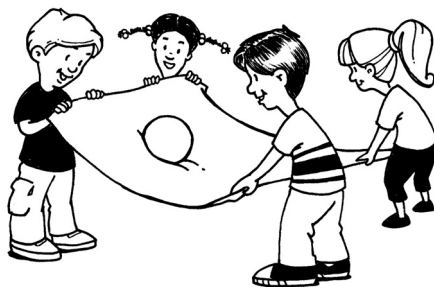

COLORING/PUZZLE CENTER



(Optional: The Bonus Theme Ideas offered in each session can be used as an additional learning center.)

HOW DO I PLAN THE TIME SCHEDULE?

• The centers in *Parable Quest* can be taught in any order, but each center should last the same amount of time. For example, in a one-hour program, groups would remain in each center for 15 minutes and groups would be able to participate in three centers. (Add 5 minutes to the first center each group attends to provide for a brief welcome time.)

• Allow 5 minutes for groups to move from center to center, following a preestablished route.

If you have more than one hour for each session, additional centers may be added or the time in each center may be lengthened (generally it is best to limit the time in each center to a maximum of 25 minutes in order to keep student interest high). If you have less than one hour for each session, use the Bible Story Center and one or two other centers of your own choosing.

Use the chart below as an example of how to schedule groups. As the number of children in your program grows, add teachers or helpers to each center to maintain a ratio of one leader for every six to eight children. You may also add duplicate centers.

	11:00-11:20	11:25-11:40	11:45-12:00
GROUP 1	WELCOME AND BIBLE STORY CENTER	WORSHIP CENTER	GAME CENTER
GROUP 2	WELCOME AND GAME CENTER	BIBLE STORY CENTER	WORSHIP CENTER

HOW DO I MAKE THE LEARNING CENTER PLAN RUN SMOOTHLY?

• Predetermine the route each group will travel, including room and building entrances and exits. Ask guides to walk their routes in advance to become familiar with all locations.

• Establish a signal (bell, air horn, music, etc.) for notifying groups when it's time to move to the next center.

• Provide labeled tables or other areas where students may leave their projects and belongings during the session.

• Provide color-coded name tags and/or hand-held flags to identify each group.

SCHEDULE OPTIONS

You can adapt the above sample schedule to the needs and interests of your church. Other centers can be added or substituted in order to meet the needs of younger or older students. In addition to the centers suggested in this course, many churches include centers for such things as snacks, recreational outdoor games (soccer, baseball, volleyball), children's choir and elective classes (cooking, wood-working, etc.).

When planning the schedule, remember to include a variety of activities in an order that will meet the needs of children. For example, if students have been sitting in the adult worship service before coming to *Parable Quest*, plan an active center at the beginning of the session. If students attend *Parable Quest* after being in Sunday School, provide a snack at the beginning of the session.

For help in planning each session's schedule, give each leader and teacher a copy of the planning page on page 238.

PARABLE QUEST

DATE(S)

LESSON # AND TITLE

TEACHING TEAM

TIME

CENTER

MATERIALS

TEACHERS

HELPERS

238

© 2010 Gospel Light. Permission to photocopy granted to original purchaser only. Parable Quest

<p>OPTION 1 (45-60 MINUTES)</p> <p>WORSHIP CENTER 15-20 minutes</p> <p>BIBLE STORY CENTER 15-20 minutes</p> <p>GAME OR ART CENTER 15-20 minutes</p>	<p>OPTION 2 (60-75 MINUTES)</p> <p>WORSHIP CENTER 15 minutes</p> <p>BIBLE STORY CENTER 15-20 minutes</p> <p>GAME CENTER 15-20 minutes</p> <p>ART CENTER 15-20 minutes</p>	<p>OPTION 3 (75-90 MINUTES)</p> <p>ADULT WORSHIP SERVICE 15 minutes</p> <p>GAME CENTER 15-20 minutes</p> <p>BIBLE STORY CENTER 15-20 minutes</p> <p>ART CENTER 15-20 minutes</p> <p>WORSHIP CENTER 15 minutes</p>	<p>OPTION 4 (75-90 MINUTES)</p> <p>GAME CENTER 15-20 minutes</p> <p>BIBLE STORY CENTER 15-20 minutes</p> <p>ART CENTER 15-20 minutes</p> <p>WORSHIP CENTER 15 minutes</p> <p>SNACK TIME 15 minutes</p>
----------------------------------------------------------------------------------------------------------------------------------------------------------------------------	------------------------------------------------------------------------------------------------------------------------------------------------------------------------------------------------------	--------------------------------------------------------------------------------------------------------------------------------------------------------------------------------------------------------------------------------------------------	---------------------------------------------------------------------------------------------------------------------------------------------------------------------------------------------------------------------------------------

Note: If you are teaching only preschoolers, plan your centers for a maximum of 15 minutes and consider adding additional centers. If you are teaching only elementary-age children, consider expanding your centers from 20 to 25 minutes.

GETTING AND KEEPING THE VERY BEST STAFF

One of the most important elements in staffing a successful program is planning how you will recruit and organize your staff. However you do it, keep in mind that the best learning and the most fun take place when there is a teacher or helper for every six to eight children.

The optimum plan for staffing is to have the same teachers in place for the entire course. Both teachers and children benefit from regular interaction. Having long-term teachers creates a wonderful opportunity for spiritual growth in students as they build relationships with adults who are faithful in demonstrating God's love.

While it may be easier to recruit teachers to teach one session at a time, such short-term staffing creates other problems. Many churches have found that rotating teachers frequently not only makes learning and growth difficult for children, but it also creates a heavy workload in administration (distributing curriculum, orienting a constant stream of new teachers, etc.).

Here are some options if long-term commitment is difficult in your situation.

- Ask teachers to teach for a shorter time period—four weeks at a time instead of 13 weeks.
- Find two teams of teachers and helpers who will each teach for two weeks at a time. Then plan to rotate the two teams so that they alternate teaching two weeks at a time. During the course of the program, teachers and children become familiar with each other and can benefit from regular interaction.
- If you must rotate some teachers on a weekly basis, make sure that you have a number of consistent people who can greet and interact with children and parents on a weekly basis.

RECRUITING TIPS

Recruiting teachers and helpers is one of the key tasks to making *Parable Quest* an effective and fun learning experience for the children of your church and community. Keep the following tips in mind as you seek the volunteers and then match their talents to the tasks to be done:

- Pray for guidance in finding the people God wants to serve in this ministry.
- Start early—at least three months before the *Parable Quest* program begins!
- Keep the leaders of all your children's ministries aware of and praying about staffing needs.
- Develop a written job description for each staff position which includes all responsibilities, physical demands and commitment.
- Make a list of potential teachers and helpers. Consider a wide variety of sources for volunteers: church membership list, new members' classes, suggestions from adult teachers or leaders, lists of previous and current teachers, and survey forms. Get recommendations from present teachers. Don't overlook singles,

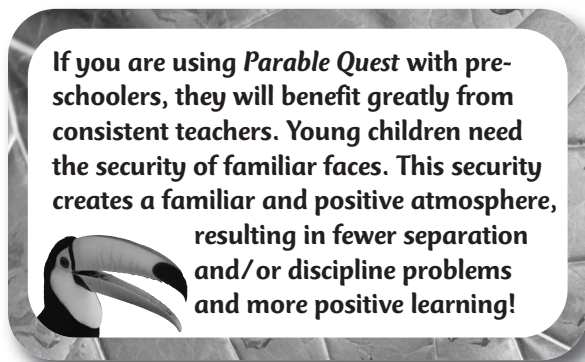

senior citizens, youth and college students. Some churches ask parents to teach during the summer months, giving school-year teachers a break. Be sure to follow your church's established procedures for screening volunteers.

- Look for team members with interests and abilities in specific areas. For example, the teaching team for 24 children might consist of three adults: one who prepares and leads the Bible Story Center each week, one who prepares and guides the Game Center and a third who prepares and leads the Worship Center. While each team member has the primary responsibility to lead only one center, all team members are involved throughout the session as helpers.
- Recruit a separate team of teachers and leaders for each center. Each team might consist of two or more adults who enjoy teaching together, or consider asking a family with teenagers to work together to form a teaching team.
- Prayerfully prioritize your prospect list. Determine which job description best fits each person's strengths and gifts.
- Personally contact the prospects. Sending a personal letter, e-mail or a flyer (see p. 21) to each prospect or calling the prospect are good first steps. Follow up to answer any questions or to see if the prospect has made a decision. Show the prospect the *Parable Quest* manual and *Parable Quest* CD-ROM. Ask the prospective volunteer what he or she would most enjoy doing as a leader or teacher in *Parable Quest*.
- Provide new volunteers with all the needed materials, forms, helpful hints and training that will help them to succeed. For all teachers and helpers, you may want to schedule one or more training meetings at which you distribute curriculum, review the schedule and procedures, sing the songs together, etc. If your church is able, provide schedules and other training articles on your church website for volunteers to access at any time.
- During the volunteer's time of service, make sure the volunteer knows who will be available to answer questions or lend a helping hand. Look for specific actions and services contributed by the volunteer and offer your thanks!
- Plan a thank-you brunch or dinner for teachers and their families. Even if they don't attend, they'll be grateful for your appreciation!
- Create and regularly update a bulletin board display that shows pictures of volunteers leading activities with kids.

RECRUITING ANNOUNCEMENTS

The team members who will be your *Parable Quest* teachers and helpers will appreciate clear, concise information about the program—and a little added inspiration couldn't hurt! Two attention-grabbing recruiting announcements are on the next page.

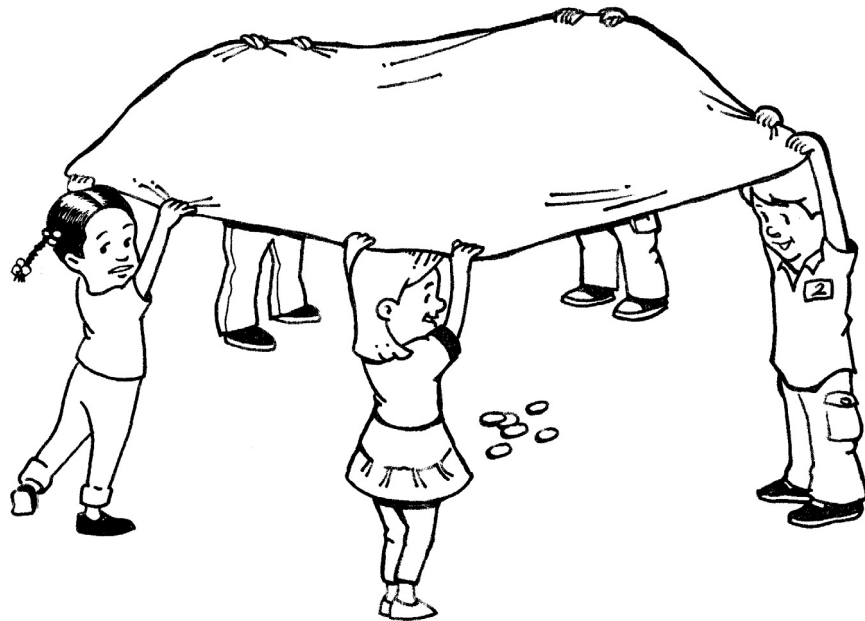

Lead Kids on a Rainforest Adventure!

Join now for the satisfaction of leading kids to discover truths from Jesus' parables! (You might learn something new yourself!) We're now taking applications for leaders and teachers who can show God's love to kids, use their imaginations and have fun helping kids understand what it means to follow Jesus on a life-changing adventure!

Parable Quest starts on _____ and continues through _____
at _____

Contact name@email.com



JOIN OUR ADVENTURE TEAM!



(date)
(time)

Be a part of our team of crack rainforest guides, leading kids on a 13-week discovery of truths from Jesus' parables!

Parable Quest has fresh new songs, fun games, worship activities and great Bible stories that will give kids new ways to discover more about Jesus! But that's not all! Our rainforest guides will keep kids coming back for more adventure through awesome art projects, tasty snacks, wacky games and more!

Act now to ensure your spot as one of our rainforest guides!

PUBLICITY GUIDELINES AND SCHEDULE

Well-planned publicity is critical to the success of any event, so take time to carefully schedule each part of your publicity plan. Publicity ideas are endless (bulletin-board displays, banners, coloring poster contests, parent letters, etc.), but be sure to include these basics: church bulletin and newsletter announcements, posters and flyers. Here is a suggested schedule:

PUBLICITY SCHEDULE

12 WEEKS BEFORE:

- Determine the exact dates on which each publicity piece will be released.
- Assign publicity tasks.

8 WEEKS BEFORE:

- Print a teaser announcement in your church bulletin and/or newsletter.

6 WEEKS BEFORE:

- Display posters in well-traveled areas at your church facility and in your community.

4 WEEKS BEFORE:

- Print information about *Parable Quest* in your church newsletter and mail flyers to children. Send mass e-mails if possible.
- Print announcements in your church bulletin on a weekly basis.

1 TO 3 WEEKS BEFORE:

- Continue bulletin announcements.
- Make verbal announcements during church worship services.



PUBLICITY IDEAS

POSTERS AND FLYERS

Use the posters and flyers on pages 239-241 to get the attention of children and families and invite them to participate in *Parable Quest*. You may also use the art on pages 234-237 to make your own posters and flyers, telling information about *Parable Quest*. Display the posters in a variety of locations around your church.

CHURCH WEBSITE

Add information about *Parable Quest* to your church's website. Consider adding an online registration feature and a course outline and schedule that will help parents become familiar with the course. Create interest in *Parable Quest* by adding a photo of several kids and teachers dressed in jungle explorer clothes (vests, jungle hats, boots, backpacks, etc.).

INFORMATION BOOTH

Decorate a booth or table in the church lobby from which to recruit teachers and helpers and preregister children. Decorate the booth or table as a jungle outpost or other rainforest motif (see "Decorating Ideas" on pp. 29-32). Prepare publicity flyers, registration forms and volunteer sign-up sheets for use at the booth.

KICKOFF EVENT

Prepare for and publicize the upcoming *Parable Quest* course with a kickoff event. Schedule the kickoff event two to three weeks before *Parable Quest* begins. Invite children and their parents to discover what the fun is all about. Publicize the event by distributing flyers to families in your church and community. Transform your church parking lot or a large multipurpose room into a rainforest. Set up three or four fun rainforest activities and offer a snack or two. Choose ideas from the Bonus Theme Ideas suggested in each lesson. Place a registration booth near the center of all the action so it is convenient for parents to register their children. Display flyers and posters at the booth.

- Each activity needs at least one adult or older teenager to be in charge. Encourage all adult and teen helpers to dress in theme-related clothing.
- Consider asking individual families in your church to sponsor activities. Each family would be responsible for purchasing supplies, setting up the activity and leading the activity during the event. In addition to having people who lead activities, have several helpers greet parents and encourage children to try an activity that is lacking participation.
- Each activity needs a designated area. In most situations, the activities can be set up outside, preferably on a lawn. One simple way to mark each area is with stakes in each corner. Then tie a rope from stake to stake, marking the boundaries of the area. If using a parking lot, draw boundaries for each area with chalk. Each activity area needs a large sign identifying the activity. Awnings and tents may also be used to designate activity areas. Restrooms need to be open and clearly marked.

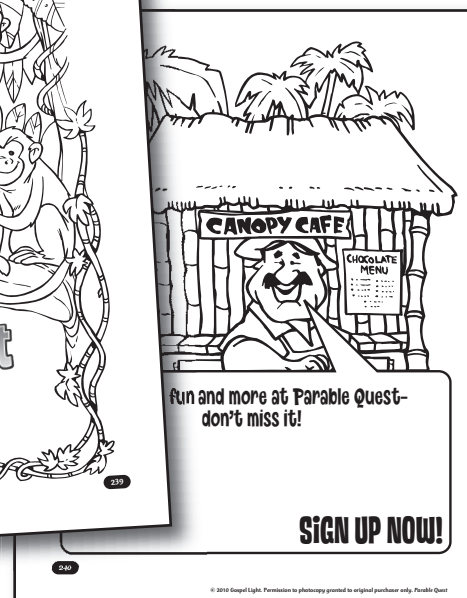

TEACHING PRESCHOOLERS AND ELEMENTARY CHILDREN TOGETHER

Whenever possible, it's recommended that you group preschool children (Ages 3 to Kindergarten) and elementary age children (Grades 1-6) separately for *Parable Quest*. Teaching is most effective when children are grouped with others at similar developmental levels. While there is some benefit in mixing children of various ages together, it is difficult to prevent the oldest children from feeling that the activities are "baby" stuff because the younger kids are also involved. Even among children of similar ages, you are likely to find a variety of skills and abilities.

However, if there aren't enough children to form separate groups for preschool- and elementary-age children, you may need to combine children of both age levels together. The tips and ideas in *Parable Quest* will help you combine children from a wide variety of ages and still provide effective teaching.

GAME AND ART CENTER TIPS

- Use the games and art activity ideas suggested for the age level of the majority of children in your class. If needed, modify the games and art activities as suggested in each lesson for either older (Grades 1 to 6) or younger (Ages 3 to Kindergarten) children. The modifications use the same or similar materials so that you don't have to collect and prepare an entirely new set of materials. If you are using this material with younger preschoolers, additional modification to the games and art activities may be needed, depending on the skill level of the children in your class.
- Use the Bible memory verse that corresponds to the age of the majority of children in the group. However, in individual conversations with children, use the age-appropriate Bible memory verse, suggestions and discussion questions found in the lesson.
- Have the older children help lead the games or have younger children cheer on their teams as the older children play.

Lesson 1

Game Center

FOR OLDER CHILDREN • LIKE 6:8-10

COLLECT
Bible, bandanna for each group of up to 10 children.

DO

1. Ask one child to be "It." Have the rest of the group form a circle (up to 10 children in a circle) holding hands. Place the end of the bandanna in the back pocket of one of the players. (Optional: Have child loosely tuck end of bandanna into his or her waistband at the back.)
2. Circle begins rotating in one direction. At your signal, "It" hops around the outside of the circle trying to grab the bandanna. When the bandanna is caught or after several unsuccessful tries, "It" joins the circle and a new "It" is chosen. (Tips: Practice the game action a few times before playing the first round. Do not signal "It" to move until bandanna is on the other side of the circle.)
3. Before "It" can take his or her turn, lead children in circle to say the words of John 1:12 with each child saying a word of the verse. For each round, vary the manner in which "It" moves (tip toe, jump, take baby steps, walk heel-to-toe, etc.).

TALK ABOUT

- When a player in this game captured the bandanna, he or she was glad. Every day you might feel glad for a lot of reasons, but today we're talking about something that can make us feel glad for our whole lives: Being part of God's family and living as His child helps us feel glad.
- In our Bible story today, Jesus says that God is joyful when we become a part of His family. Why do you think God is joyful? (God loves each person so much that He wants everyone to live as His children.)
- Read John 1:12. What does this verse say is the result of believing in Jesus? What do you think it means to say that you are a child of God? (A child of God believes that Jesus is God's Son. A child of God accepts God's love and forgiveness. A child of God loves and obeys God.)
- We can ask God's help in understanding what it means to believe in Jesus. Lead children in prayer, asking God's help in believing in the good news of Jesus.

FOR YOUNGER CHILDREN

Children form circles of up to six children each. When you signal "go," children begin passing bandanna around the circle. When you signal "stop," child holding bandanna waves it in the air. Call out "God loves (Mason)" and lead all children in cheering and clapping. Repeat until each child has been named.

GOD'S WORD
"To all who received him, to those who believed in his name, he gave the right to become children of God."
John 1:12

FOR YOUNGER CHILDREN
"Believe in Jesus and you will be God's child."

GOD'S WORD & ME
When you believe in Jesus and become a part of God's family, everyone in heaven rejoices!

52

© 2010 Gospel Light. Permission to photocopy granted to original purchaser only. Parable Quest

BIBLE STORY CENTER TIPS

- Even if children of varying ages are combined for art and game activities, consider keeping the Bible Story Center as a center through which small groups of children of similar ages rotate. Then the leader of the center can tailor the story to each particular group, ensuring that all children are taught the Bible story on their own level.
- If you have primarily elementary-age children, use the Bible Story Center Option for Older Children. However, provide for preschoolers the lesson's coloring page as a way to involve them and extend their interest in the story.
- If you have mostly preschoolers, use the Bible Story Center Option for Younger Children. Invite elementary-age children to participate by acting out the story or drawing Bible story murals.

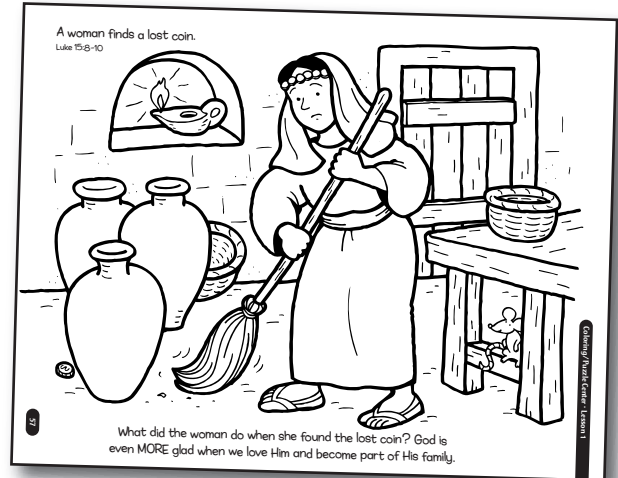

WORSHIP CENTER TIPS

- While preschoolers are not likely to feel comfortable volunteering for the fun team games and other activities, they will still enjoy cheering for their teams.
- Make sure that the teachers and helpers of the preschoolers sit among the children to provide security and attention.
- Set aside space for preschoolers to sit at the front of the Worship Center area so that they are able to see.
- Make a copy of the music on the *Parable Quest* CD-ROM for each child to take home. Familiarity with the songs will help preschoolers feel comfortable in the large-group setting. Although preschoolers may not be able to remember all the words of a song, they will easily catch on to and sing the song's chorus and can still participate by doing motions and/or by clapping or by playing rhythm instruments such as shakers or bells.

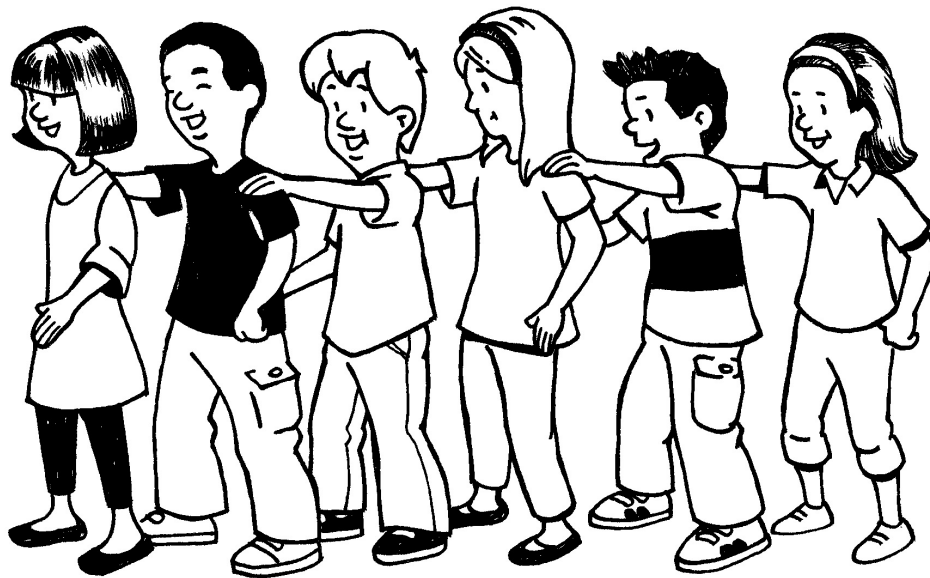

OUTREACH IDEAS

Because *Parable Quest* is packed with loads of exciting hands-on learning activities, you won't want any student to miss it! And because this program is also a great place for unchurched kids to learn about God in a relaxed, inviting atmosphere, you'll want to publicize it—even beyond your church! Here are ideas to help you not only plan to invite children to participate in *Parable Quest*, but also to follow up on visitors.

INVITATION IDEAS

- Keep accurate enrollment records for your ongoing children's programs. Several weeks prior to the beginning of *Parable Quest*, send postcards or flyers (see pp. 239-241), or make phone calls to children who have either stopped attending your church or who have visited recently.
- Offer a small prize to any child who brings a friend to attend *Parable Quest*. (Note: Adapt one of the flyers on pp. 239-241 for use as invitations children can give to friends.) Each week be prepared to welcome visitors by having a greeter(s) who can help visitors find the appropriate classrooms, make name tags available, and record contact information on registration forms. Consider recognizing visitors each session during the Worship Center. (Note: Prepare enough name tags so that visitors have same tags as other children.)
- Plan with the adult ministry coordinator to offer a parenting or other special-interest class at the same time children will be participating in *Parable Quest*.
- Make a large outdoor banner or paint a large sign (see pattern on p. 234) and hang it in a visible place outside your church.
- Mount flyers in businesses frequented by children and their families (grocery stores, laundromats, etc.) and on community bulletin boards.

FOLLOW-UP

- Invite parents to attend a special celebration as part of the final *Parable Quest* session (see invitation on p. 233). Children sing songs for their parents, families may tour classrooms and everyone enjoys a snack or barbeque. Encourage teachers and leaders to make a special effort to introduce themselves to parents and look for natural opportunities to build friendships, answer questions about the church, etc.
- During the 13 weeks of *Parable Quest*, encourage teachers and leaders to contact their students, including absentees, visitors or irregular attendees. Provide already-stamped postcards, prepared mailing labels, and address and phone lists.
- Take one or more photos of children during *Parable Quest* and ask leaders and teachers to personally deliver photos to children's homes at the end of the program. You may also e-mail photos to parents. (Obtain parent permission for use of photos.)
- Make a *Parable Quest* Memory CD with lots of photos showing the variety of activities in which children participated. Send each CD to children who attended and include an invitation to other upcoming church programs.
- Pray for the teachers, leaders and helpers and remind them to pray for the children in their groups, asking God to bring to their minds appropriate ways to keep in touch with the children and to nurture them in Christ.

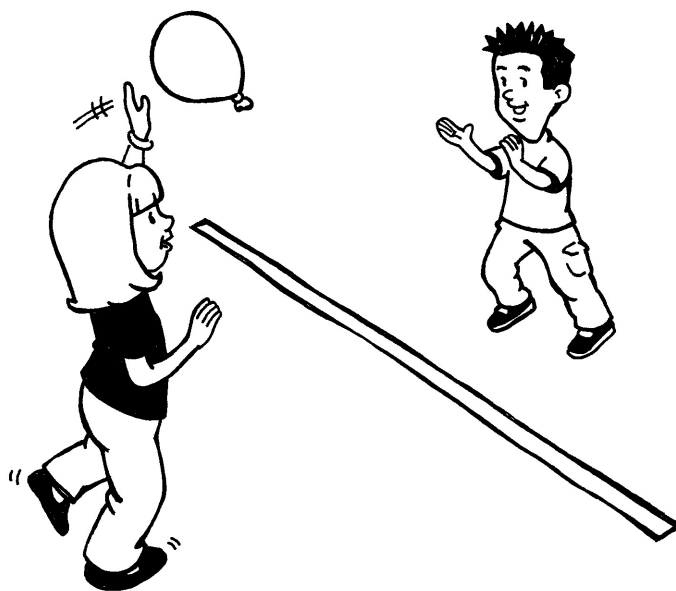

PARTNERING WITH PARENTS

In Deuteronomy 6:7, God commanded parents to teach their children about Him “when you sit at home and when you walk along the road, when you lie down and when you get up.” The most important learning in life takes place not in churches, schools or scout troops but in families. The hours and days parents and children spend together are the prime opportunities for building long-lasting spiritual foundations!

Choose one or more of the following ideas for ways you can help parents in their awesome responsibility of spiritually teaching their children.

- Send home the Parent Letter (p. 232) to each parent at the beginning of the program and include a copy of the *Parable Quest* Scope and Sequence so that parents are aware of the content and goals of this course.
- Offer a free or low-cost kid-friendly Bible to parents when they register their children for *Parable Quest*. Especially if your program will attract visitors or unchurched children, it's wise not to assume that every family will have a kid-friendly Bible.
- If you don't use the Coloring Page or Puzzle Page in each session, send them home with children each week. Include an introductory letter with the first lesson's Coloring or Puzzle Page, explaining that these pages can provide an opportunity for parent and child to talk about Jesus' parables and how the Bible verses can make a difference in each family's life.

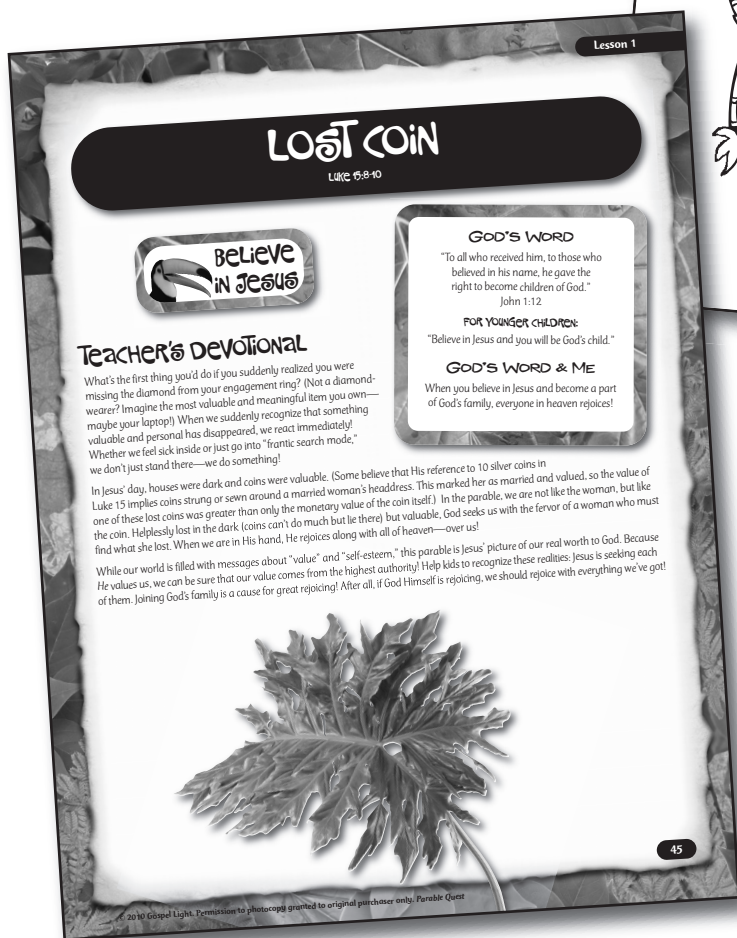
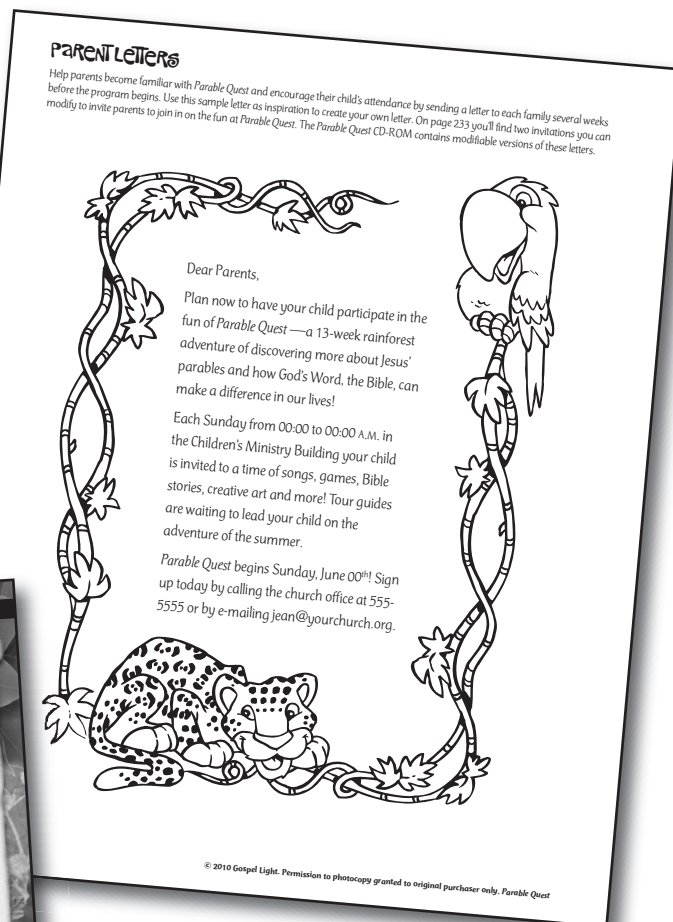

- Consider giving each parent a copy of the first page of each session. As parents read the devotional, they will develop an understanding not only of how they can model and demonstrate the focus of the session but also how they can talk with their children about the session's Bible truth.

- Give parents of elementary-age children a copy of the Family Talk page (p. 231) and the *Parable Quest* Scope and Sequence page (p. 11). Encourage parents to use these with their children each week to read and study either the session's Bible story references or the Bible Memory Verse. You may choose to give a small prize or candy to each child who brings a completed Family Talk page to each session.

- Make a copy of the music on the *Parable Quest* CD for families to listen to at home or in the car.

- Ask parents to support *Parable Quest* by providing a special snack or by preparing the materials for an art activity or game. Invite the parent to join in on the fun! (See invitation on p. 233.) Observing the way in which teachers and leaders talk with children about the session's Bible content will model for parents effective ways of spiritual education. (Note: You may want to invite each parent to schedule a session when they will observe a full class session with his or her child.)

- For the length of *Parable Quest*, invite parents to attend a parent support/prayer group that meets together twice a month or weekly to pray for their children, their teachers and each other. Enlist several parents to serve as hosts for this group. Hosts call parents to invite them to participate, arrange meeting space (homes, if possible), provide coffee, snacks, etc.

- Establish a group Bible memory verse contest in which all parents and children work together to memorize a certain number of the memory verses from *Parable Quest*. If the goal is met, promise a party at which children create and eat snacks and play fun games (see Bonus Theme Ideas in each lesson). Using the patterns on pages 234-237, make a fun poster on which to record the number of verses memorized (large sheet of paper to which each parent and each child who can say a verse adds a spot to a large jaguar cut-out, or a large sheet of poster board to which each parent and each child who can say a verse adds a leaf to a vine). (Avoid identifying individual memory efforts.) Display the poster in a central area and have several people serve as Bible memory listeners. During arrival or dismissal, parents and children repeat verses.

- Plan Family Days several times throughout the course as suggested on the Bonus Theme Ideas pages in various lessons.

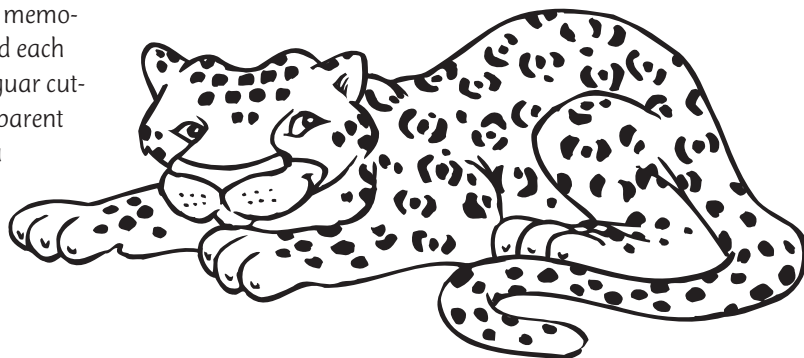
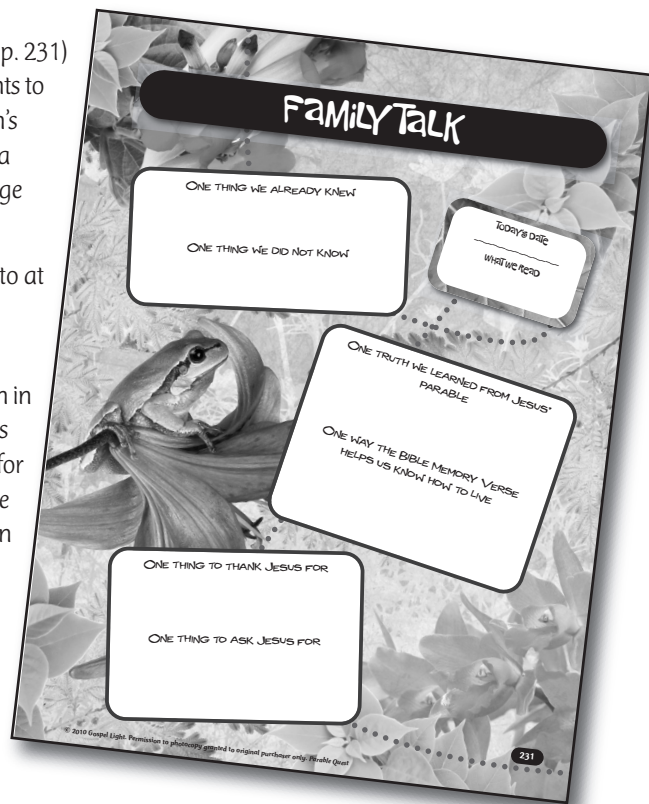

DECORATING IDEAS

No matter where you choose to hold your program, decorating the rooms where the action will take place can add fun and excitement to the proceedings! Children and teachers both will enjoy spending time in a theme-related atmosphere. A few simple decorations can transform an ordinary classroom into part of an exciting rainforest. Use a variety of real items and/or painted backdrops. Use the patterns on pages 234-237 to help you create the perfect atmosphere for both fun and learning. Recruit people who love to plan and prepare for a party as your decorating team.

If you cannot leave decorations on the walls from week to week, you may attach painted backdrops to rolling bulletin boards to be brought in during the sessions. You may also make murals on large sheets of butcher paper. Roll up murals after each session.

CREATE A PLACE

Name and label one or more rooms as different areas of the rainforest, especially if you are using a center method with this course. Places such as The Rainforest River, Rainforest Critters, Jumping Jungle Room, Toucan's Treetop, Tropical Treehouse and Wild Waterfall can create enthusiasm for this course. Decorate each room (or outdoor location) appropriately. Here are three ideas (see sketches on pages 30-32):

• WILD WATERFALL

Create a setting that will help your kids feel like adventurous explorers of a mysterious rainforest river. Enlarge the Rainforest Backdrop Pattern (p. 30) onto butcher paper, fabric, cardboard, muslin, Styrofoam or wood. Talk with someone in your church or community who is familiar with painting backdrop scenes and determine which material would work best for your backdrop. Paint and attach backdrop to the wall. Set out live or artificial tropical plants and trees around the room. For even more fun, place green light bulbs in lamps, plug in strings of green mini-lights or tape green cellophane over fluorescent light figures and windows to cast a rainforest glow.

• RAINFOREST CRITTERS

Play games or create art projects at Rainforest Critters, featuring the sights of an amazing collection of animals and bugs. To create an intriguing display of animals, begin by enlarging the Rainforest Canopy Backdrop Pattern (p. 31) onto butcher paper (or other material), paint and attach to the wall. Hang artificial flowering vines around doorways and walls. Place plastic and stuffed toy rainforest birds and animals around the room. In a corner, or at the base of a decorated wall, lay brown butcher paper or drop cloth. Place a layer of cocoa chip mulch (available at plant nurseries) on top. Arrange some logs and branches. Set plastic toy frogs or other reptiles on logs.

• TOUCAN'S TREETOP

Decorate a room or large area as Toucan's Treetop. Enlarge the Horizon Backdrop Pattern (p. 32) onto butcher paper (or other material), paint and attach to one wall. Above the mural attach blue butcher paper sky. Paint a rainbow in the sky. Glue puffs of fiberfill on sky for clouds. Decorate the room with hanging birds (see patterns on pp. 234-237). (Optional: Cover tables with toucan or sky print fabric. To add one or more trees, make textured trunks and limbs by twisting and scrunching brown butcher paper or brown plastic tablecloth material (found on the roll at fabric stores) and attach to wall. Paint butcher paper to look like tree tops and attach to wall above trunk. Glue on green tissue paper or streamers to add additional foliage.







THEME IDEAS

The Bonus Theme Ideas offered in every session will add an unforgettable dimension to *Parable Quest*. Here are additional ways to fill your church with the sights and sounds of a rainforest adventure.

SCENERY

Use the decorating ideas on pages 29-32 to decorate the classrooms and activity centers.

Set up a decorated entrance such as vines or artificial plants around the doorway where children enter every day as they arrive at *Parable Quest*. Issue each child a rainforest-themed nametag (see pattern on p. 234).

SOUNDS

The *Parable Quest* CD-ROM provides lively songs to help your students learn Bible truths. These memorable songs help students and adults alike discover that they are on a life-changing adventure when they understand how Jesus and God's Word can make a difference in their lives.

At the beginning and end of each Worship Center segment, ask a volunteer to dress as a jungle explorer and ring a bell, play a trumpet or blow an air horn. You may also use this sound to signal transition times in your schedule.

Groups of children will enjoy creating their own chants or cheers to say while moving between centers or while entering the assembly area.

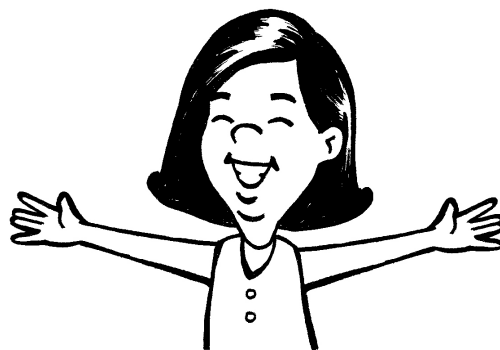

SPECIAL DAYS

Build interest and create enthusiasm for *Parable Quest* by asking students, teachers and helpers to bring in or wear items to enhance the fun. Consider doing one or more of the following:

- **Hat Day** Children and leaders wear fun, funny and fantastic hats that they bring from home or that they make at *Parable Quest* using a variety of art supplies.
- **Funny Hair Day** Encourage everyone involved in *Parable Quest* to come up with his or her most outrageous hairstyle.
- **Rainforest Clothing** Ask children and leaders to wear clothing representing typical rainforest explorers (t-shirts with animal designs, jungle hats, vests, etc.).
- **Color of the Day** Using the color of your choice, children and leaders wear the color of the day in their clothing or even their hair!
- **Wacky Sunglasses Day** Encourage everyone involved in *Parable Quest* to wear sunglasses—the more colorful the better!

STAFF NAMES AND GROUP NAMES

- **Director** Expedition Leader, or a name of a fun rainforest explorer such as Jungle Janis, Toucan Tom, etc.
- **Teachers and Helpers** Rainforest Guides, or let each teacher and helper create their own nicknames.
- **Group Names** Type of rainforest animals (Jaguars, Monkeys, Butterflies, Toucans, etc.). (Optional: Give each group a sheet of poster board to make a sign for their group. Groups carry signs as they rotate from center to center.)

CURRICULUM RESOURCES

Familiarize yourself with the Bonus Theme Ideas provided for each lesson. Each session includes a variety of ideas for decorating, snacks, rainforest activities, etc.

BIBLE STORY CENTER TIPS

Since many of Jesus' parables are well known and may be familiar to the children in your program, be ready to acknowledge their awareness of the parables. Keep their interest by inviting children to tell the story details; be ready to supplement what they forget and to clarify the story as needed. You may also ask children to think about why this story of Jesus has become so well known—what was Jesus trying to say that is so important to us today? Best of all, if children are familiar with the parable, move quickly beyond the facts to the life application of the parable's truth. Use the discussion questions provided in this curriculum and make good use of the time to lead children in a significant discussion about how to put God's Word into practice.

Most of us can still remember a childhood story told by a good storyteller. What makes a good storyteller so memorable? A good storyteller draws listeners into the story, helping them imagine the story themselves and thus making it their own. You may not feel like one of the world's great storytellers, but fortunately, effective storytelling is a skill that you can develop by following the suggestions in this curriculum and by practicing a few simple principles. Here are some ideas and tips to help you become more confident and memorable!

A GOOD BEGINNING AND ENDING

A good beginning is essential, because it is much easier to capture an audience than it is to recapture them after their attention has wandered.

ADVENTURE BOX

To help you make the most of the opening minutes of the Bible story, each story in *Parable Quest* makes use of an Adventure Box. The Adventure Box can be any wooden or cardboard box with the word "Adventure" written on it and tied up with a rope or yarn. Each lesson suggests several storytelling items to be placed in the Adventure Box and brought out during the story to keep children's interest. For younger children, there is also a fun rainforest activity (no materials required) that will help you gather children together. For older children, a fun game is suggested that will help you connect an element of the Bible story with a familiar childhood experience.

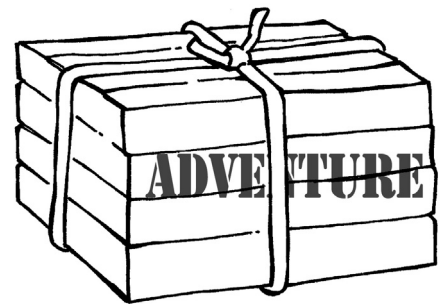

SUGGESTED MATERIALS FOR YOUNGER CHILDREN'S ADVENTURE BOX

For every lesson, place a Bible in the Adventure Box. In addition, place the following items:

- Lesson 1: Flashlight, whisk broom, a small cooking pan with lid and 10 coins.
- Lesson 2: Salt shaker, a small flashlight and a large bowl.
- Lesson 3: Flat rock, a rectangular cake pan containing a shallow layer of sand, a small box or a toy house, cup of water.
- Lesson 4: Four resealable plastic bags, each bag containing one of the following: hard-packed dirt, rocky soil, weedy soil and potting soil.
- Lesson 5: Paper plates (one for each child) on which you have drawn a simple sheep's face.
- Lesson 6: Toy or paper crown and three paper plates on which are drawn a sad face, a happy face and an angry face.
- Lesson 7: Four toy people, several lunch-size bags filled with newspaper and taped shut to represent hills, and four or five blocks with which to build an inn.
- Lesson 8: Blanket or shawl, an unsliced loaf of bread, bread knife and bread board.
- Lesson 9: Resealable bag containing grain [rice, oats or wheat], a child's toy barn [or blocks you can use to build a small barn] and a toy person representing a farmer.
- Lesson 10: Fancy-looking invitation card, a fancy plate, cup and utensils.
- Lesson 11: Sack of real or plastic coins, several party items (hats, streamers, cups, plates, etc.) and stuffed animal pig.
- Lesson 12: Wooden or cardboard blocks and two toy people.
- Lesson 13: Large grocery bag, a medium-sized grocery bag and a small grocery bag, each stuffed nearly full with newspaper.

SUGGESTED MATERIALS FOR OLDER CHILDREN'S ADVENTURE BOX

For every lesson, place a Bible in the Adventure Box. In addition, place the following items:

- Lesson 1: Flashlight, whisk broom, a small cooking pan with lid and 10 coins.
- Lesson 2: Salt shaker, either a small flashlight or a candle and matches, and large ceramic bowl.
- Lesson 3: Flat rock, rectangular cake pan containing a shallow layer of sand, a small box or a toy house, cup of water.
- Lesson 4: Four pots, each pot containing one of the following: hard-packed dirt, rocky soil, weedy soil and potting soil.
- Lesson 5: Bag of 100 cotton balls, large plastic bowl and stuffed toy sheep.
- Lesson 6: Toy or paper crown, a large paper bag stuffed with newspaper and stapled shut, a small lunch bag stuffed halfway with paper and stapled shut.
- Lesson 7: Signs with "Boo!" "Groan" and "Yeah" written on them for use in melodrama.
- Lesson 8: Blanket or shawl, a flashlight, an unsliced loaf of bread, a bread knife, a bread board, a plastic snake or scorpion.
- Lesson 9: Resealable bag containing grain [rice, oats or wheat] and a set of interlocking blocks.
- Lesson 10: Fancy-looking invitation card, a fancy plate, cup and utensils.
- Lesson 11: Sack of plastic or real coins, several party items [hat, streamers, cups, plates, snacks], stuffed animal pig, Bible-times robe and a fancy ring.
- Lesson 12: Two Bible-times costumes or headdresses (fabric squares and cloth strips).
- Lesson 13: Five grocery bags and real or plastic coins.

BIBLE STORY CONCLUSION

Each story also provides a conclusion—a brief summary of the basic focus of the story and how the Bible truth presented in the story connects with everyday life. This conclusion is called God's Word and Me. In the conclusion, a brief prayer is suggested. For elementary-age children, several discussion questions are provided for you to use in helping them express their understanding of the Bible story and the Bible verse. If the Bible story is told in a large group of more than 16 children, form small groups for the discussion time.

STORYTELLING TIPS

- Practice telling the story aloud. Tell the story to yourself or someone in your family. Make notes or briefly outline the story.
- Have your open Bible at hand while you are telling the story. Tell older children in which book of the Bible the story may be found. If appropriate, you may plan to read some of the story directly from your Bible. Referring to the Bible reinforces the idea that the Bible stories are true and are found in the Bible. With preschoolers, frequently repeat that the stories are true and are written in the Bible for us to read.
- While the Bible story is being told, other teachers and helpers sit separately among the children. Encourage them to fully participate with children, reacting appropriately and having fun! Their listening presence will encourage children to listen attentively as well, and they can help redirect children's attention back to the storyteller if needed.
- Use dramatic facial expressions and vary your tone of voice according to the story action. When possible, add drama and excitement to the story by telling the story from the perspective of a person in Bible times, dress in Bible-times costumes or paint or draw symbols while telling the Bible story.
- If students indicate a familiarity with the story, ask volunteers to tell some of the story action. Be sure to clarify and supplement information as needed.
- Keep your story brief. A good rule of thumb for a beginning teacher is to limit your story to one minute for each year of the children's age. If you have more than one age level in your group, target for the middle of the group, but be ready to shorten the story if the younger ones are restless.
- Work at maintaining eye contact with your children throughout the story. Know your story well enough that you can glance at your Bible and your notes and then look up.

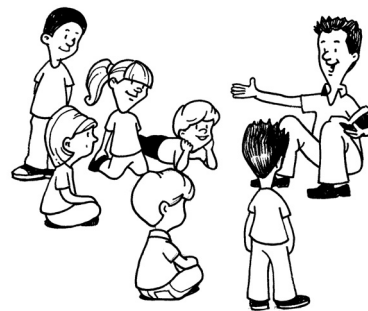

ART CENTER TIPS

The Art Center is a place where children can become absorbed in a creative activity as a way of expressing their understanding of how the lesson's focus relates to their lives. Each art activity incorporates discussion of the Bible story and/or the Bible verse. In each art activity, the questions you ask and the comments you make will encourage students to apply Bible truth to everyday life. When students' hands are busy, they often talk freely!

CHOOSE THE APPROPRIATE ACTIVITY

In each session, an art activity is provided for older children (elementary age) and for younger children (preschool age). Provide two centers, one for each age level. If you cannot provide two centers, choose the activity for which you have the most children. Each activity also includes a way to modify the activity (using the same or similar materials) for either younger or older children.

BEFORE YOU BEGIN

Preparation is the key to making an art experience a joyful, creative one. No one enjoys a long stretch of waiting for a stapler or scissors. So make sure you have the following supplies on hand: newspaper (to protect surfaces), functional scissors, usable glue bottles and sticks, working markers, usable crayons and chalk, an adequate supply of tape, paint smocks (or men's old shirts) and butcher paper or newsprint end rolls (ask at your local newspaper office).

BEFORE EVERY ACTIVITY

Before students arrive at your center, cover the work table(s) with newspaper or plastic table cover, securing it with masking tape, if needed. Set out materials in an orderly fashion, making sure you have enough materials for the number of children who will visit the Art Center.

If table space is limited, set out materials on a nearby shelf or supply table. Allow students to get and return materials to the appropriate places.

If most of your students are younger, use older students as helpers (for distributing supplies, stapling, etc.) during the Art Center time.

AS CHILDREN CREATE

While children are working on their art creations, look for natural opportunities to ask the questions listed at the bottom of each Art Center page to help children relate the Bible story and/or the Bible verse to their daily lives. As children create, they are relaxed and eager to talk. Guided discussion will take the activity beyond art to discovery of Bible truth.

Avoid making value judgments as children create ("That's nice." or "How pretty!"). First, any child who then doesn't hear such a positive judgment will be crushed. Second and most important, focusing on the visual appeal of the artwork will not help children better understand the lesson. How a child's work *looks* is far less important than the child's *process* of creating that work and how the child can better understand the lesson. Comment on colors, lines and ideas you see represented. **Jenna, I see you used lots of colors on your project. Tell me about your work.** As you invite children to tell you about their work, many opportunities will arise for you to ask the discussion questions printed in bold type at the bottom of the page or to make comments that will help children understand the lesson focus.

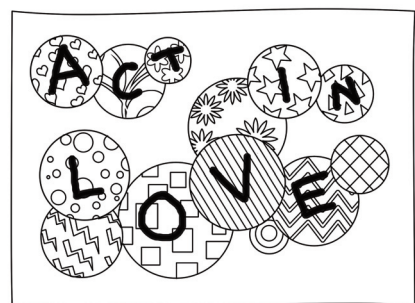
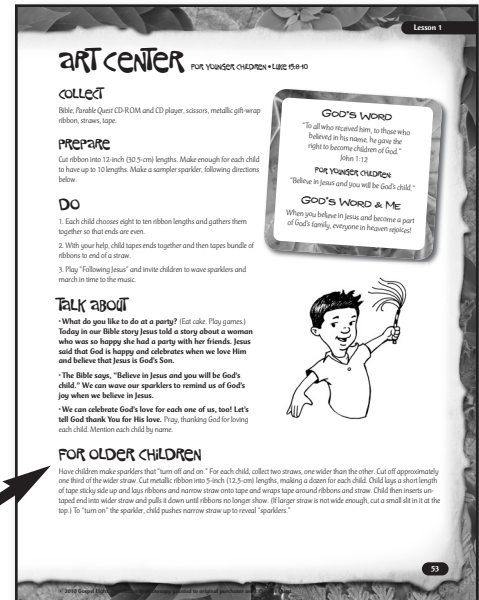

GAME CENTER TIPS

The Game Center can be the perfect place for your students to let off steam, work out the wiggles and be open to guided discussion that relates the Bible story and/or Bible verse to students' lives.

CHOOSE THE APPROPRIATE GAME

In each session, a game is provided for older children (elementary age) and for younger children (preschool age). Provide two centers, one for each age level. If you cannot provide two centers, choose the game for which you have the most children. Each game also includes a suggested modification (using the same or similar materials) for either younger or older children.

CREATING A PLAY AREA

Before leading a game, give yourself ample time to set up the play area. You may have little space in your classroom for a play area, so consider alternatives: outdoors, a gymnasium or a vacant area of the church from which sound will not carry to disturb other programs.

Once you have chosen the area, plan what you will need.

- Will you need to move furniture?
- Will you need to mark boundaries? Use chalk or rope outdoors; yarn or masking tape works indoors. (Remove masking tape from carpets after each session.)
- How much space will you need? Carefully review the game procedures to plan what amount and shape of space will be needed.

From time to time, take stock of your classroom area. Is it time to remove that large table or unused bookshelf? Should the chairs be rearranged or the rug put in a different place? Small changes in arrangement can result in more usable space!

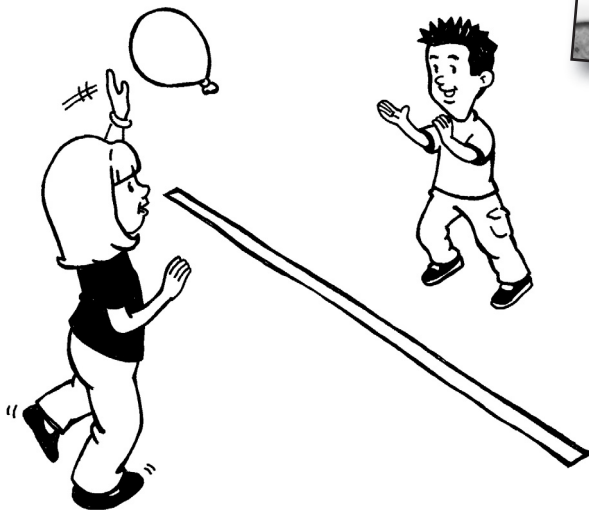

GAME CENTER FOR YOUNGER CHILDREN • LUKE 15:8-10 Lesson 1

COLLECT
Bible, adhesive labels, marker, coins, large piece of green fabric.

PREPARE
Write numbers on each label to make a set of matching numbers. Number enough labels so that each child will have one. (Note: Depending on the number of children in your group and the size of fabric, you may need to have additional pieces of fabric.)

DO

1. Place coins on the floor and spread out large piece of green fabric over the coins. Give each child a numbered adhesive label to wear. Gather children around the fabric. **Let's pretend that we are in our rainforest and a canopy or covering of leaves is over our heads!** Children pick up the fabric by the edge and hold it high over their heads.
2. Call out one of the numbers written on labels. Children wearing label with that number run under the fabric, pick up a coin and run back to their places.
3. Continue until each child has had a turn to collect a coin. Repeat game as time and interest permit.

TALK ABOUT

- In our Bible story today, Jesus told a story about a woman who lost a valuable coin. When she found the coin, she was happy and she celebrated. The Bible says that God is even MORE happy and joyful when we believe that Jesus is God's Son.
- God loves us so much! God wants each one of us to be part of His family. The Bible says, "Believe in Jesus and you will be God's child."
- God's love is for everyone. Who are some of the people God loves? (Help children name friends and family members.)
- We are glad to know that God loves us. We're glad to know that Jesus is God's Son. Pray briefly, Dear God, thank You for Your love. Thank You that we can be part of Your family. In Jesus' name, amen.

FOR OLDER CHILDREN
When numbers are called, all children let go of the fabric. Children try to collect the coins and return to their places before the fabric falls to the floor.

GOD'S WORD
"To all who received him, to those who believed in his name, he gave the right to become children of God."
John 1:12

FOR YOUNGER CHILDREN:
"Believe in Jesus and you will be God's child."

GOD'S WORD & ME
When you believe in Jesus and become a part of God's family, everyone in heaven rejoices!

© 2010 Gospel Light. Permission to photocopy granted to original purchaser only.

51

FORMING GROUPS OR TEAMS

To keep students' interest high and to keep cliques from forming, use a variety of ways to determine teams or groups.

- Group teams by clothing color or other clothing features (wearing a sweater, wearing tennis shoes, etc.).
- Place equal numbers of two colors of paper squares in a bag. Students shake the bag and draw out a square to determine teams.
- Group teams by birthday month (for two teams, January through June and July through December); adjust as needed to make numbers even.
- Group teams by the alphabetical order of their first or last names.
- Group teams by telling them to stand on one foot: Those standing on a right foot form one team; those standing on a left foot form the other team.

After playing a round or two of a game, announce that the person on each team who is wearing the most (red) should rotate to another team. Then play the game again. As you repeat this rotation process, vary the method of rotation so that students play with several different students each time.

LEADING THE GAME

Explain rules clearly and simply. It's helpful to write out the rules to the game. Make sure you explain rules step-by-step.

Offer a practice round. When playing a game for the first time with your group, play it a few times just for practice. Students will learn the game's structure and rules best by actually playing the game.

GUIDING CONVERSATION

Your comments and questions during the game can turn the game into Bible learning! Make use of the discussion questions provided in the curriculum throughout the game time. You might ask a game's winners to answer questions or to consult with each other and answer as a group. You might discuss three questions between the rounds of a game or ask a question at the beginning of the round, inviting answers when the round is over.



COLORING/PUZZLE CENTER TIPS

The Bible story coloring and puzzle pages provided for each lesson in *Parable Quest* provide an activity that you can use in several ways. These pages may be used as the basis of a separate activity center in which the youngest children (preschoolers and early elementary age) complete the coloring page and the older children (older elementary age) work on the puzzle. The coloring pages illustrate the lesson's Bible story. The puzzle pages help children think further about the lesson's life application as they review the Bible story or Bible verse or discover a life-related challenge. Both pages lead to opportunities for discussion about ways to obey God's Word.

Alternatively, these pages can be used to supplement an existing center. For example, a Bible story coloring page can be provided for younger children to help them think and talk about ways to put God's Word into practice. Or children who complete an art activity before others can be challenged to complete the coloring or puzzle page. Coloring and puzzle pages can also be kept for use when an activity runs short.

The coloring and puzzle pages may also be sent home with children on a weekly basis as a way of extending their Bible learning into the home. In addition, the coloring pages can be copied onto transparencies, projected and traced onto butcher paper and used for wall murals or bulletin boards.

PREPARATION

- It's easiest to copy all the pages needed at one time, rather than photocopying on a weekly basis. Store the pages in marked folders for easy use.
- If you plan to use markers for the coloring pages, photocopy those pages onto heavier stock to avoid marker bleed-through.
- Provide a variety of art materials for coloring; in addition to crayons and markers, colored pencils and watercolors add interest.
- Have the puzzle answer sheets (pp. 242-245) available for children who are working on the Bible puzzle pages.

DISCUSSION OPPORTUNITIES

While students are coloring or working on the puzzles, ask the questions suggested on the coloring or puzzle pages. Using these questions will help you connect the coloring or puzzle activity to the Bible story or Bible verse. Encourage student participation by introducing each question with a statement such as **I'm looking for four students wearing red to answer this question.** Another way to attract the interest of students is to say, **Someone whose name begins with the letter J can answer this question.**

Consider storing each child's coloring and/or puzzle pages in a folder or in a binder. As time permits, refer to these pages as a way of reviewing past lessons. At the end of *Parable Quest*, give pages to children to take home.

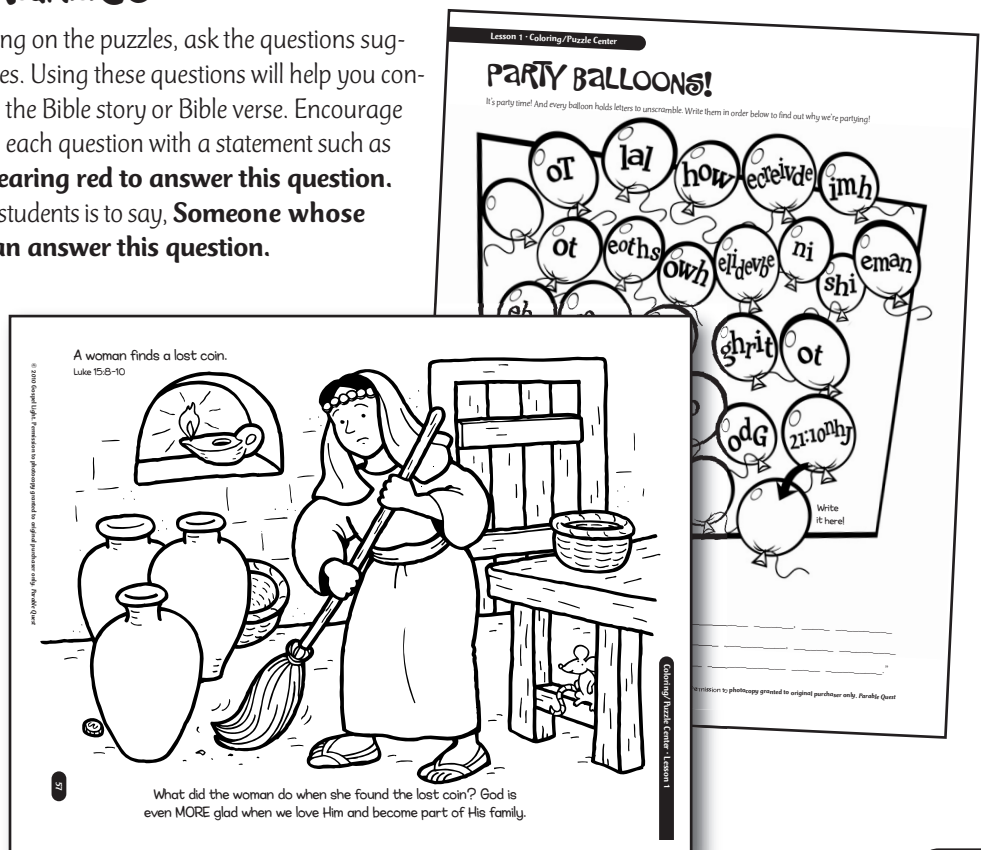

WORSHIP CENTER TIPS

The Worship Center is a large-group gathering time for preschool- and elementary-age children that is best scheduled at the beginning or the end of each session. The goal is to help children participate in meaningful worship and build enthusiasm for discovering more about Jesus' parables and how the Bible verses can make a difference in children's lives. Fun games, lesson-related music, saying or reading God's Word and prayer are all provided in the Worship Center.

Plan to have an enthusiastic youth-group-type leader guide the Worship Center activities. Ask him or her to dress in theme-related clothing—perhaps with a unique hat, vest or t-shirt, etc.—to help establish his or her character. Consider giving a name to the leader (Jaguar Jack, Rita River, etc.) to catch kids' attention.

Playing either "Following Jesus" or "Rainforest Sounds" as children gather for the Worship Center will help catch children's interest for *Parable Quest*.

GAMES

Each week a wacky game is suggested that will catch everyone's attention and involve children in team-building camaraderie. Often the game requires representatives from two or more teams. The number of children on a team may vary, depending on group size. Although not all children (especially preschoolers) will feel comfortable getting up in front to lead or participate in a game, they will enjoy being part of a team and cheering for their teammates.

WORSHIP TIMES

Adults sometimes see children's worship time as occupying kids with frenzied repetitions of "Father Abraham" or as simply teaching children to worship in the same way as adults. But children need informal worship opportunities at their own level of understanding. Worship experiences designed to meet children's needs help them respond in love and praise to their heavenly Father.

Worship is indeed a time to show reverence and respect for God, but it doesn't mean always sitting still and being quiet. The activities offered in the Worship Center involve children and help them interact with each other and with teachers in singing praise to God and hearing His Word.



A PLACE OF WORSHIP

Worship is also enhanced by setting apart a place especially for praising Him. To create a space in your classroom for the Worship Center, prayerfully consider the ages and abilities of the children in your group, the kind of worship experience appropriate for them and the time and space available.

Consider ideas such as displaying a contemporary picture of Jesus, spreading a rug on the floor upon which children sit, and playing a theme-related song as a signal to begin worship.

If taking an offering, singing a particular response or placing candles on an altarpiece are part of your church's adult worship, occasionally add those elements to the Worship Center as well. Give a simple explanation to help children understand why each of these acts is part of worship.

Keep in mind that the Worship Center is not just a place for entertainment or observation; your goal is to see every child participate in a positive way that is in keeping with his or her development.

MUSIC JUST FOR YOU!

Consider making copies of the music on the *Parable Quest* CD-ROM to help your students become familiar with the songs used during *Parable Quest*. A variety of musical styles are represented, making it easy for you to customize your worship time to include your students' favorites.

LEADING SONGS

Each of the upbeat songs on the *Parable Quest* CD-ROM is designed to help children be aware of the opportunities they have every day to live as Jesus' followers.

Children may participate by singing, clapping, playing rhythm instruments, holding up word charts, operating the overhead projector or adjusting the CD player. Help children understand that all these activities have one goal: to honor and praise God. Your example of sincere worship sets the tone—it is the strongest teaching about worship the children will receive.

Learning new songs can be difficult for some teachers. Listen to the song on the *Parable Quest* CD-ROM. Then play the song again and sing along. Practice it several times (listen to it while driving in the car, while you cook, etc.). You may want to choose three or four favorite songs from the *Parable Quest* CD-ROM and repeat them at each session, rather than teaching a variety of new songs. The younger the children are, the more repetition should be provided.

To teach a new song to children, print the words on a large chart or use the song charts in this book (pp. 246-254) to make a transparency to project on an overhead projector or to make PowerPoint slides. Project the words on a place where they may be seen easily by all the children.

As you play the song, sing along with the song, inviting children to join in with you. It is usually a good idea to sing only one stanza and/or chorus the first time through. If you are using an overhead, cover the entire transparency with a blank sheet of paper. As you sing, move the paper to reveal words one line at a time. Creating motions for some of the words or phrases in the songs will also help children learn the songs.

CHOOSING ADDITIONAL SONGS

If your church chooses to lead children in additional worship songs, select songs with the same prayer and sensitivity with which you'd plan adult worship. Utilizing simple worship choruses and hymns from among your own church's favorites will prepare children for the transition to adult-level worship in a gradual, age-appropriate manner. In this way, children will become familiar with a body of songs used in adult worship.

Whatever songs you use, be sure to explain any words or concepts that are unfamiliar to children. If unfamiliar words are used, take the time to give a brief definition of the word. Use a children's Bible dictionary if needed. For example, **The word "holy" means to be chosen or set apart. When we sing that God is holy, it means that He is perfect and without sin.** If you cannot put the words or concepts of a song in terms a child can truly understand, recognize that the song is probably appropriate only for adult worship.

BIBLE VERSE

The fun verse activity provided encourages students to hear and/or say the Scripture in a creative way that invites their participation. While children may often memorize the verse as part of this activity, Bible memory is not the primary goal. Instead, the goal is simply the interactive reading or hearing of God's Word.

If the reading abilities of children and the number of teachers permit, children may find and read the verse in Bibles as part of this activity.

Consider printing out each week's verse on a computer banner for easy reading. If possible, use PowerPoint slides to display the verse. Copy stores can make posters on poster board for you.

PRAYER TIME

Prayer is an integral part of worship. Don't deny children this privilege because they seem unable to hold still with folded hands and bowed heads for long periods of time. Instead, involve children in prayer in ways that will help them understand that prayer is something they can do. Don't insist that students pray in a particular posture; keep prayer times short and make them times of high involvement. Remember that your prayers give the students in your class a model for prayer that they will follow. Keep your prayers brief and use simple words. Long sentences and long prayers make prayer seem boring and not something for a child.

Each Worship Center provides prayer activity ideas for large-group prayer at the end of the Worship time. Invite children to pray silently, aloud, to say sentence prayers, record requests and answers in a prayer journal, or list prayer requests on a large sheet of paper (allow children to pray with eyes open so that they are able to read and recall requests).

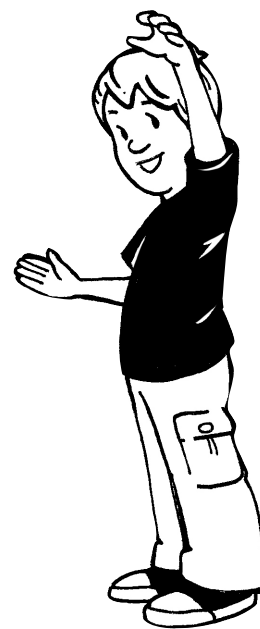
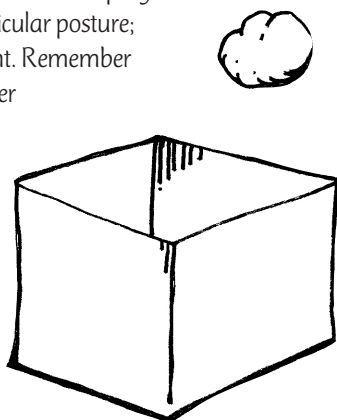



PARABLE QUEST LESSONS

In this section are each lesson's instructions. Before each session, print, photocopy and distribute the lesson to each teacher and leader. Or you may e-mail the lessons to teachers and leaders.

LOST COIN

LUKE 15:8-10



TEACHER'S DEVOTIONAL

What's the first thing you'd do if you suddenly realized you were missing the diamond from your engagement ring? (Not a diamond-wearer? Imagine the most valuable and meaningful item you own—maybe your laptop!) When we suddenly recognize that something valuable and personal has disappeared, we react immediately! Whether we feel sick inside or just go into “frantic search mode,” we don't just stand there—we do something!

In Jesus' day, houses were dark and coins were valuable. (Some believe that His reference to 10 silver coins in Luke 15 implies coins strung or sewn around a married woman's headdress. This marked her as married and valued, so the value of one of these lost coins was greater than only the monetary value of the coin itself.) In the parable, we are not like the woman, but like the coin. Helplessly lost in the dark (coins can't do much but lie there) but valuable, God seeks us with the fervor of a woman who must find what she lost. When we are in His hand, He rejoices along with all of heaven—over us!

While our world is filled with messages about “value” and “self-esteem,” this parable is Jesus' picture of our real worth to God. Because *He* values us, we can be sure that our value comes from the highest authority! Help kids to recognize these realities: Jesus is seeking each of them. Joining God's family is a cause for great rejoicing! After all, if God Himself is rejoicing, we should rejoice with everything we've got!

GOD'S WORD

“To all who received him, to those who believed in his name, he gave the right to become children of God.”

John 1:12

FOR YOUNGER CHILDREN:

“Believe in Jesus and you will be God's child.”

GOD'S WORD & ME

When you believe in Jesus and become a part of God's family, everyone in heaven rejoices!



PLANNING PAGE

Choose which centers you will provide and the order in which children will participate in them (see pp. 14-18 for schedule tips and pp. 24-25 for guidelines in combining older and younger children). Also plan who will lead each center (for staffing tips see pp. 19-21). Use the reproducible planning sheet (p. 238) to record your plans.

BIBLE STORY CENTER

BIBLE STORY

Lost Coin • Luke 15:8-10

ADVENTURE BOX (YOUNGER CHILD)

Use props (flashlight, whisk broom, a small cooking pan with lid and 10 coins) to demonstrate story action

ADVENTURE BOX (OLDER CHILD)

Child uses props (flashlight, whisk broom, a small cooking pan with lid and 10 coins) to act out the story

GAME CENTER

YOUNGER CHILD OPTION

Collect coins from under a rainforest canopy and talk about God's joy when we believe in Him

MATERIALS

Bible, adhesive labels, marker, coins, large piece of green fabric

OLDER CHILD OPTION

Play a fun game, trying to grab a bandanna, and then talk about the joy that believing in Jesus brings

MATERIALS

Bible, bandanna for each group of up to 10 children

ART CENTER

YOUNGER CHILD OPTION

Make and wave ribbon sparklers while listening to music that expresses joy because of believing in Jesus

MATERIALS

Bible, *Parable Quest* CD-ROM and CD player, scissors, metallic gift-wrap ribbon, straws, tape

OLDER CHILD OPTION

Make sparkly balls to play catch with while saying the words of John 1:12

MATERIALS

Bible; 2-inch [5-cm] Styrofoam ball, six 2-foot (0.6-m) metallic ribbons and a 6-inch [15-cm] foil square for each child; scissors; several pens; glue

COLORING/PUZZLE CENTER

YOUNGER CHILD OPTION

Review the Bible story while completing coloring page

MATERIALS

Lesson 1 Coloring Page (p. 57) for each child, crayons

OLDER CHILD OPTION

Review John 1:12 while completing puzzle page

MATERIALS

Lesson 1 Puzzle Page (p. 58) for each child, pencils

WORSHIP CENTER

FOR THE YOUNGER AND OLDER CHILD

Participate in large-group activities to review Bible verse and to worship God together

MATERIALS

Bibles, *Parable Quest* CD-ROM and CD player, song charts (pp. 246-247)

BONUS THEME IDEAS

Bonus Theme Ideas can be used at any time during this session: as an additional activity center, to extend the session for a longer time, or for added theme excitement.

RAINFOREST FLOWERS

Set out Fruit Roll-Ups® and/or Fruit Streamers® in a variety of colors (including green). Children use scissors to cut fruit snacks into leaf and flower shapes, arranging the shapes on waxed paper. (Tip: Suggest children cut geometric shapes [circles, squares, rectangles and triangles] to use in creating rainforest flowers.) Create a few leaves and flowers yourself and take advantage of this time to build relationships with children. After showing off their creations, children eat and enjoy!

Post a note alerting parents to the use of food. Also, check registration forms for possible food allergies.



TOUCAN SHOUTOUTS!

On a bulletin board or wall, attach a length of light blue butcher paper. Make tree and toucan cutouts using the patterns on page 235-236. Attach tree and toucan to butcher paper, placing the toucan on a tree branch. From brightly colored paper, cut a large conversation balloon. Print this lesson's shoutout "Believe in Jesus" on the conversation balloon and attach it near the toucan. For each lesson, create a similar conversation balloon using a different paper color for the conversation balloon.

RAINFOREST IN A BAG

For every child, gather the lower half of a 2-liter soda bottle, a small plant (philodendron or other tropical plant) and a gallon-sized resealable storage bag. Also collect pebbles, spoons and potting soil. Have water available in pitchers or watering cans. **Today you can create a rainforest in a bag. During Parable Quest we can watch our rainforests grow.** Child puts approximately 1-inch (2.5-cm) of pebbles into the bottle half and then adds about twice as much potting soil as pebbles. After using a spoon to make a small hole in the soil, child places plant in the hole and covers with soil. Child gently pours water into the bottle until he or she can see water collecting in the pebbles and then places bottle into the bag and seals the bag. Set "rainforests" in an area with indirect light.

BIBLE STORY CENTER

FOR YOUNGER CHILDREN • LUKE 15:8-10

INTRODUCTION

Welcome your rainforest explorers by saying **Hello, (Madison)** and leading all children to clap on each syllable of child's name. Repeat for each child in the group. Then show Adventure Box. **What do you think is in our Adventure Box today? Let's find out!** Untie box. Remove items from box and use them to demonstrate story action as you tell the story and/or lead children in suggested motions.



ADVENTURE BOX

In a cardboard or wooden box labeled "Adventure," place a Bible, and one or more of these props: flashlight, whisk broom, a small cooking pan with lid and 10 coins. Tie rope or brown yarn around the box or crate.

TELL THE STORY

Do you like to hear stories? I do! The Bible tells us that Jesus told MANY stories while He was living on Earth. We can read Jesus' stories right here in the Bible. *(Show Bible.)*

Some people were glad to hear what Jesus said. But other people were NOT. *(Lead children to shake head no.)*

In fact, some of them were angry at Jesus. These angry people thought that Jesus should ONLY talk to people who did good things. But Jesus knew that God had sent Him to show love to ALL people. *(Lead children to spread out arms.)* So one day Jesus told a story to help people understand how much God loves EVERYONE. This is what Jesus said.

"Once there was a woman who had 10 silver coins. *(Invite children to hold up hands and count fingers.)* These coins were worth a lot of money. She may have gotten them when she got married. But one day the woman noticed that one of her coins was MISSING!

"The woman was very worried! She lit a lamp, so she could see all around her house. She looked in every corner! *(Pretend to look all around the room.)* Then she took a broom and carefully swept the floor. *(Pretend to sweep.)* She looked under the bed. She looked in her clothes. She looked inside the jars, cups, dishes and pots. *Where could it be?* she wondered.

"Finally, the woman found the coin! She was VERY happy and VERY excited! She ran to tell all her friends, 'I found my coin! I found my coin! Please celebrate with me!' All her friends and neighbors were glad, too—they celebrated with her." *(Invite children to clap hands and cheer with you.)*

Jesus said that when we believe that Jesus is God's Son and become part of His family, God celebrates just like the woman did.

GOD'S WORD & ME

The woman was joyful because she found her coin. The Bible says that God is even MORE happy and joyful when we believe that Jesus is God's Son. God loves us so much! God wants each one of us to be part of His family. The Bible says, "Believe in Jesus and you will be God's child." Pray, Thank You, God, for loving us. We love You and we are glad to be Your children. In Jesus' name, amen.

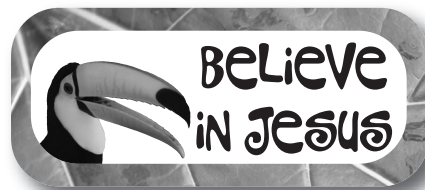

BIBLE STORY CENTER

FOR OLDER CHILDREN • LUKE 15:8-10

INTRODUCTION

Introduce the story by leading children to play a game of “Who’s Got the Button?” substituting a coin for a button. To play the game, children stand in a circle with hands behind their back. One child stands in the middle of the circle. Secretly give a coin to one child in the circle. At your signal, children begin passing the coin behind their backs. Child in the middle tries to guess who has the coin. After a correct guess or three incorrect guesses, a new child takes a turn to be in the middle. **Today we’re going to hear why Jesus told a story about someone who lost a valuable coin.**

What do you think is in our Adventure Box today? Let’s find out!

Untie box. Remove items from box and invite a child to use them to demonstrate story action as you tell the story. (Optional: Ahead of time, videotape a woman dressed in Bible-times clothing telling the story and pantomiming the story action. Show video during the Bible story.)

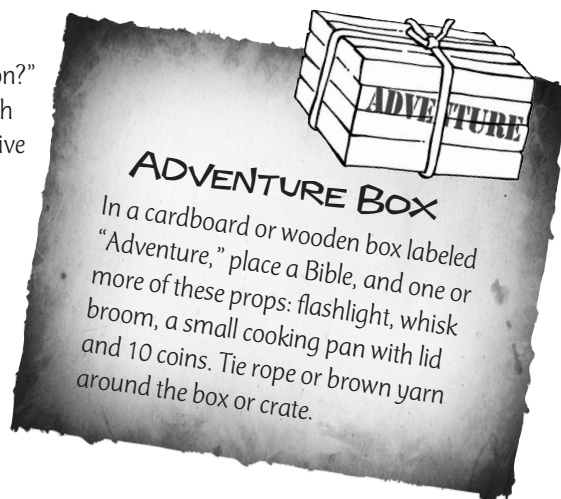

TELL THE STORY

Jesus told many stories while He was living on Earth. Some people were glad to hear what Jesus said. But other people, especially the religious leaders, were not. The religious leaders were called Pharisees. One day, the Pharisees were talking about Jesus.

“If Jesus is so wonderful, why does He waste His time eating with people who have not followed God’s laws? They are sinners,” they muttered.

Jesus knew the Pharisees didn’t understand that God wanted Him to show His love to all people. So Jesus told this story to help them understand that God loves and values every person He has made!

A woman had 10 silver coins. These coins were valuable and worth a lot. They were probably the special coins she had gotten when she got married. One day the woman noticed that one of her coins was MISSING!

Oh no, she probably thought. What will I do? What would you have done if you were that woman?

(Child who volunteers uses the props to pantomime the actions of the woman. Encourage volunteer to use dramatic facial expressions and actions.)

The woman lit a lamp. Then she took her broom and began to carefully sweep the floor of her small, dark house. She probably looked under the beds and behind all the furniture. She looked in the pockets of all her clothes and looked down inside the deepest jars. She shined her light into every cup and dish and pot!

Now, the woman could have looked once and then said, “Oh, well, I give up!” After all, she had nine more coins of equal value! But no, she looked and looked and LOOKED. She didn’t STOP looking until, SUDDENLY, she found her coin. She was SO happy! She ran to tell her friends.

“I found my coin! I found my coin! Please, come help me celebrate!” she called out. And all her friends and neighbors were glad and celebrated with her!

Before we become members of God’s family, we are lost like that coin! We are valuable to God. He treasures us! But God did not give up looking because we were lost. No, He sent Jesus to make it possible for us to be part of God’s family forever. Jesus did that by dying on the cross to take the punishment for the sins, or wrong things we’ve done. But Jesus didn’t STAY dead. He came back to life to prove that even death doesn’t have power over Him!

When we ask God to forgive our sins and we join God’s family, He is even happier than the woman who found the coin she had lost! Jesus said that God His Father—and everyone else in heaven—is joyful and celebrating every time another person comes to join His family!

GOD'S WORD & ME

If you are part of God's family, did you know that God and everyone in heaven celebrated when you joined His family? That's because we matter to God. He'll never stop looking for us and never stop loving us! If you are not part of God's family yet, or if you have questions about becoming a member of God's family, today would be a good time to think about that and talk to your parents or me about your questions. Let children know when you will be available to talk with them.

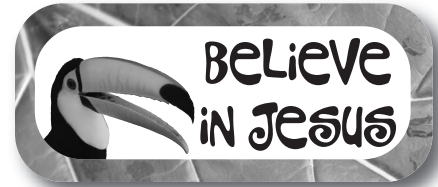

- **What are ways we know God loves us?** (Made us. Cares for us. Gave us families. Sent Jesus to die for our sins.)
- **What are some things a kid your age might say are sins or wrong things to do?** (Tell a lie. Hit someone when angry. Steal. Say bad words.) **When we become part of God's family, the wrong things we do are forgiven, and God will help us follow Him.**
- **What does our verse say God gives us when we believe in Jesus?** (The right to become His children.) **That's right! John 1:12 says, "To all who received him, to those who believed in his name, he gave the right to become children of God."**

Pray with children, asking God's Spirit to help them know how much God loves them and to help them understand God's offer of salvation through Jesus. Invite children interested in talking about joining God's family to meet with you after class (see page 12 for "Leading a Child to Christ").



GAME CENTER

FOR YOUNGER CHILDREN • LUKE 15:8-10

COLLECT

Bible, adhesive labels, marker, coins, large piece of green fabric.

PREPARE

Write numbers on each label to make a set of matching numbers. Number enough labels so that each child will have one. (Note: Depending on the number of children in your group and the size of fabric, you may need to have additional pieces of fabric.)

DO

1. Place coins on the floor and spread out large piece of green fabric over the coins. Give each child a numbered adhesive label to wear. Gather children around the fabric. **Let's pretend that we are in the rainforest and a canopy or covering of leaves is over our heads!** Children pick up the fabric by the edge and hold it high over their heads.
2. Call out one of the numbers written on labels. Children wearing label with that number run under the fabric, pick up a coin and run back to their places.
3. Continue until each child has had a turn to collect a coin. Repeat game as time and interest permit.

TALK ABOUT

- In our Bible story today, Jesus told a story about a woman who lost a valuable coin. When she found the coin, she was happy and she celebrated. The Bible says that God is even **MORE** happy and joyful when we believe that Jesus is God's Son.
- God loves us so much! God wants each one of us to be part of His family. The Bible says, "Believe in Jesus and you will be God's child."
- God's love is for everyone. Who are some of the people God loves? (Help children name friends and family members.)
- We are glad to know that God loves us. We're glad to know that Jesus is God's Son. Pray briefly, Dear God, thank You for Your love. Thank You that we can be part of Your family. In Jesus' name, amen.

FOR OLDER CHILDREN

When numbers are called, all children let go of the fabric. Children try to collect the coins and return to their places before the fabric falls to the floor.

GOD'S WORD

"To all who received him, to those who believed in his name, he gave the right to become children of God."

John 1:12

FOR YOUNGER CHILDREN:

"Believe in Jesus and you will be God's child."

GOD'S WORD & ME

When you believe in Jesus and become a part of God's family, everyone in heaven rejoices!

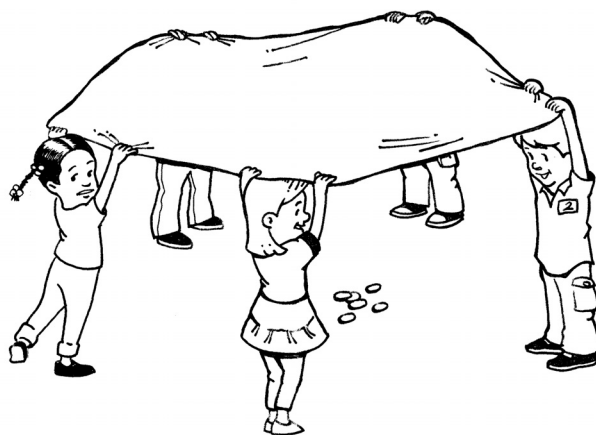

GAME CENTER

FOR OLDER CHILDREN • LUKE 15:8-10

COLLECT

Bible, bandanna for each group of up to 10 children.

DO

1. Ask one child to be "It." Have the rest of the group form a circle (up to 10 children in a circle) holding hands. Place the end of the bandanna in the back pocket of one of the players. (Optional: Have child loosely tuck end of bandanna into his or her waistband at the back.)
2. Circle begins rotating in one direction. At your signal, "It" hops around the outside of the circle trying to grab the bandanna. When the bandanna is caught or after several unsuccessful tries, "It" joins the circle and a new "It" is chosen. (Tips: Practice the game action a few times before playing the first round. Do not signal "It" to move until bandanna is on the other side of the circle.)
3. Before "It" can take his or her turn, lead children in circle to say the words of John 1:12 with each child saying a word of the verse. For each round, vary the manner in which "It" moves (tip toe, jump, take baby steps, walk heel-to-toe, etc.).

TALK ABOUT

- **When a player in this game captured the bandanna, he or she was glad. Every day you might feel glad for a lot of reasons, but today we're talking about something that can make us feel glad for our whole lives. Being part of God's family and living as His child helps us feel glad.**
- **In our Bible story today, Jesus says that God is joyful when we become a part of His family. Why do you think God is joyful?** (God loves each person so much that He wants everyone to live as His children.)
- **Read John 1:12. What does this verse say is the result of believing in Jesus? What do you think it means to say that you are a child of God?** (A child of God believes that Jesus is God's Son. A child of God accepts God's love and forgiveness. A child of God loves and obeys God.)
- **We can ask God's help in understanding what it means to believe in Jesus.** Lead children in prayer, asking God's help in believing in the good news of Jesus.

FOR YOUNGER CHILDREN

Children form circles of up to six children each. When you signal "go," children begin passing bandanna around the circle. When you signal "stop," child holding bandanna waves it in the air. Call out "God loves (Mason)" and lead all children in cheering and clapping. Repeat until each child has been named.

GOD'S WORD

"To all who received him, to those who believed in his name, he gave the right to become children of God."

John 1:12

FOR YOUNGER CHILDREN:

"Believe in Jesus and you will be God's child."

GOD'S WORD & ME

When you believe in Jesus and become a part of God's family, everyone in heaven rejoices!

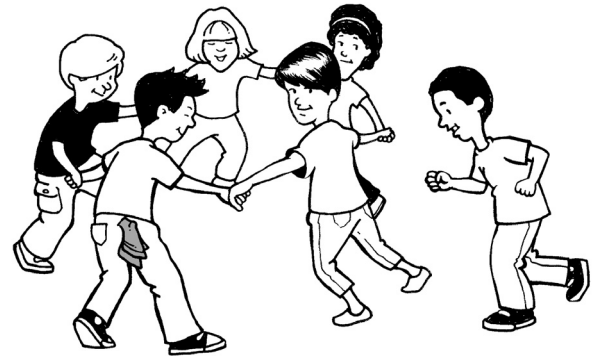

ART CENTER

FOR YOUNGER CHILDREN • LUKE 15:8-10

COLLECT

Bible, *Parable Quest* CD-ROM and CD player, scissors, metallic gift-wrap ribbon, straws, tape.

PREPARE

Cut ribbon into 12-inch (30.5-cm) lengths. Make enough for each child to have up to 10 lengths. Make a sampler sparkler, following directions below.

DO

1. Each child chooses eight to ten ribbon lengths and gathers them together so that ends are even.
2. With your help, child tapes ends together and then tapes bundle of ribbons to end of a straw.
3. Play "Following Jesus" and invite children to wave sparklers and march in time to the music.

TALK ABOUT

- **What do you like to do at a party?** (Eat cake. Play games.) Today in our Bible story Jesus told a story about a woman who was so happy she had a party with her friends. Jesus said that God is happy and celebrates when we love Him and believe that Jesus is God's Son.
- The Bible says, "Believe in Jesus and you will be God's child." We can wave our sparklers to remind us of God's joy when we believe in Jesus.
- We can celebrate God's love for each one of us, too! Let's tell God thank You for His love. Pray, thanking God for loving each child. Mention each child by name.

FOR OLDER CHILDREN

Have children make sparklers that "turn off and on." For each child, collect two straws, one wider than the other. Cut off approximately one third of the wider straw. Cut metallic ribbon into 5-inch (12.5-cm) lengths, making a dozen for each child. Child lays a short length of tape sticky side up and lays ribbons and narrow straw onto tape and wraps tape around ribbons and straw. Child then inserts untaped end into wider straw and pulls it down until ribbons no longer show. (If larger straw is not wide enough, cut a small slit in it at the top.) To "turn on" the sparkler, child pushes narrow straw up to reveal "sparklers."

GOD'S WORD

"To all who received him, to those who believed in his name, he gave the right to become children of God."

John 1:12

FOR YOUNGER CHILDREN:

"Believe in Jesus and you will be God's child."

GOD'S WORD & ME

When you believe in Jesus and become a part of God's family, everyone in heaven rejoices!



ART CENTER

FOR OLDER CHILDREN • LUKE 15:8-10

COLLECT

Bible; 2-inch [5-cm] Styrofoam ball, six 2-foot (0.6-m) metallic ribbons and a 6-inch [15-cm] foil square for each child, scissors, several pens, glue.

PREPARE

Make a sample sparkly ball, following directions below.

DO

1. Give each child a Styrofoam ball.
2. Child chooses six ribbons and ties ends together in a knot (see sketch a). Trim off excess above knot. Child uses pen to poke a hole in ball, squeezes a small amount of glue into hole and inserts knot of ribbon into the hole (see sketch b).
3. Wrap a foil square around the ball (see sketch c). Children say words of Bible verse as they play catch with the sparkly balls.

TALK ABOUT

- **What do you think are the most important words in John 1:12? Why? What's the main message someone needs to know from this Bible verse?**
- **How would knowing this verse make a difference in someone's life?** (Remind them of God's love. Tells them what to do to be part of God's family.)
- **Why would you tell someone to become God's child?** (God is like a perfect father. God has promised to help His children.)
What do you know about Jesus that makes you want to believe in Him?
- **What do people need to do to become part of God's family?** Pray, asking God to help each child understand what it means to believe in Jesus and how to join God's family.

FOR YOUNGER CHILDREN

Photocopy Lesson 1 Pattern Page (p. 56) and cut it apart. Make enough copies so that each child can choose one of the greetings on the page. Give each child a sheet of construction paper to fold into a card. Child chooses greeting, glues it inside card, decorates and takes home to give to friend or family member.

GOD'S WORD

"To all who received him, to those who believed in his name, he gave the right to become children of God."

John 1:12

FOR YOUNGER CHILDREN:

"Believe in Jesus and you will be God's child."

GOD'S WORD & ME

When you believe in Jesus and become a part of God's family, everyone in heaven rejoices!

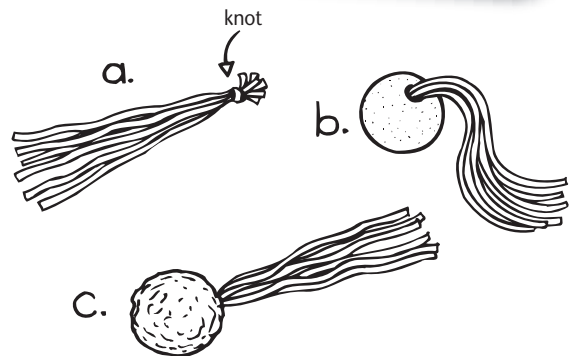

WORSHIP CENTER

LUKE 15:8-10

COLLECT

Bibles, *Parable Quest* CD-ROM and CD player, song charts (pp. 246-247).

TEAM GAME

Invite four to six volunteers to stand in front of group. Secretly assign to each volunteer a rainforest animal (jaguar, pink dolphin, monkey, frog, toucan, butterfly, snake, bat, tarantula, etc.). At your signal, each volunteer poses as a statue of the animal. Children in audience try to guess identity of each animal. Repeat with new volunteers and other animals. (Optional: While volunteers are posing, announce that you are going to try to make these statues move. Choose one of the statues and make up a funny description of him or her, trying to make the volunteer move, make noise or smile. As you continue, children watch to see if any "statue" moves, makes noise or smiles.)

BIBLE VERSE GAME

Children form circle. Count off to 10 around the circle. Each child numbered 10 says the words of John 1:12 aloud. (Optional: Child may choose one other person in the circle to ask for help.) After numbering off around the entire circle, call out "Scramble." Children scramble to find new places and reform the circle. Number off again. Repeat activity as time and interest permit.

SONG

You, or another leader, lead children in singing "Following Jesus," adding motions and/or clapping if desired.

PRAYER

Today we've been talking about God's love for us and how He celebrates when we become members of His family. Let's see if we can go through the alphabet saying the name of a friend or family member that begins with each letter of the alphabet. If we can't think of a name, then everyone must do five jumping jacks. Begin by calling out the letter "A." (Optional: With older children, challenge them to see how fast they can call out the names.) Then lead children in prayer, thanking God for His love and for making it possible for us to become members of His family.

SONG

You, or another leader, lead children in singing "God Gave," adding motions and/or clapping if desired.

GOD'S WORD

"To all who received him, to those who believed in his name, he gave the right to become children of God."

John 1:12

FOR YOUNGER CHILDREN:

"Believe in Jesus and you will be God's child."

GOD'S WORD & ME

When you believe in Jesus and become a part of God's family, everyone in heaven rejoices!

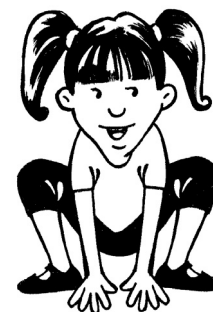

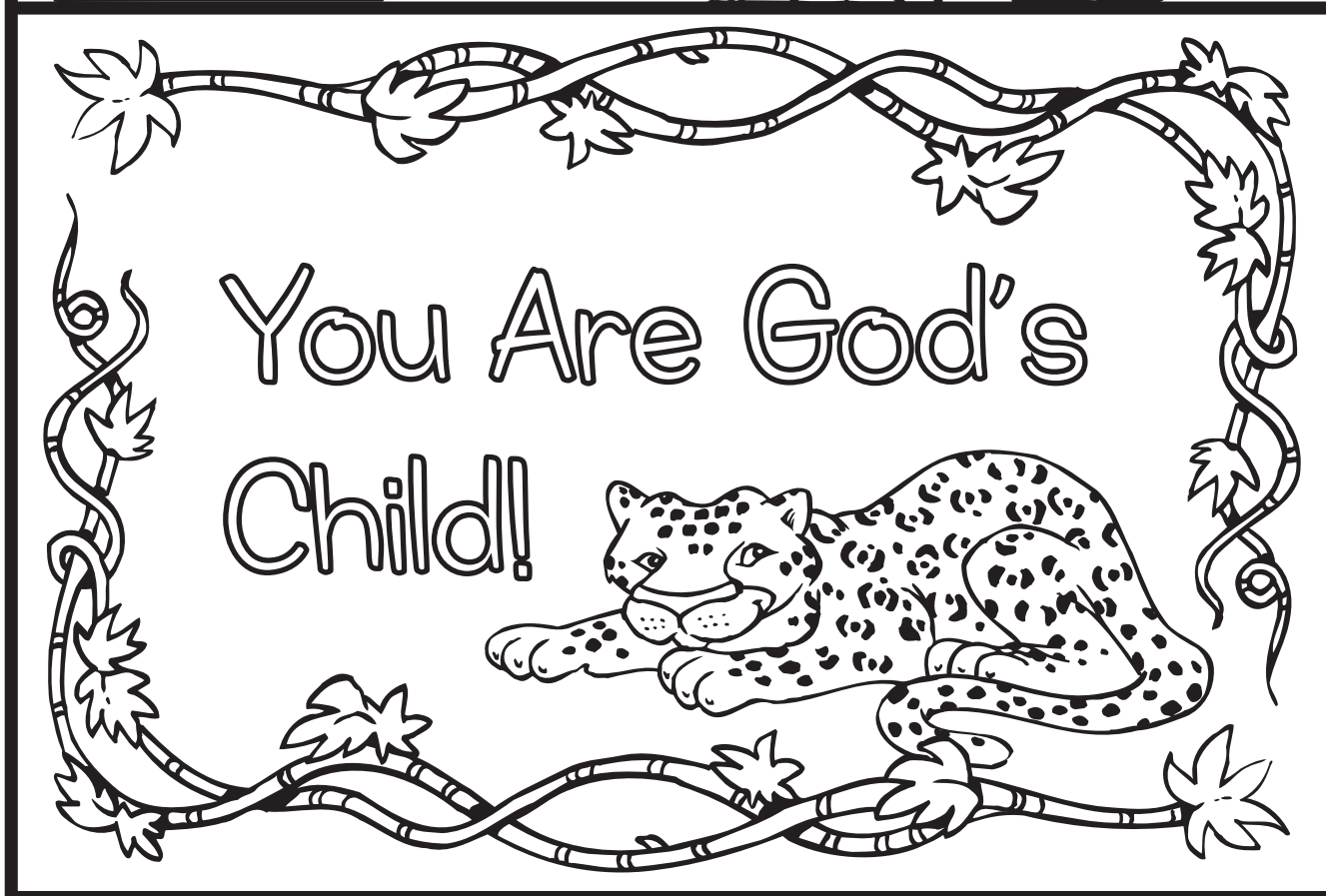

A woman finds a lost coin.
Luke 15:8-10

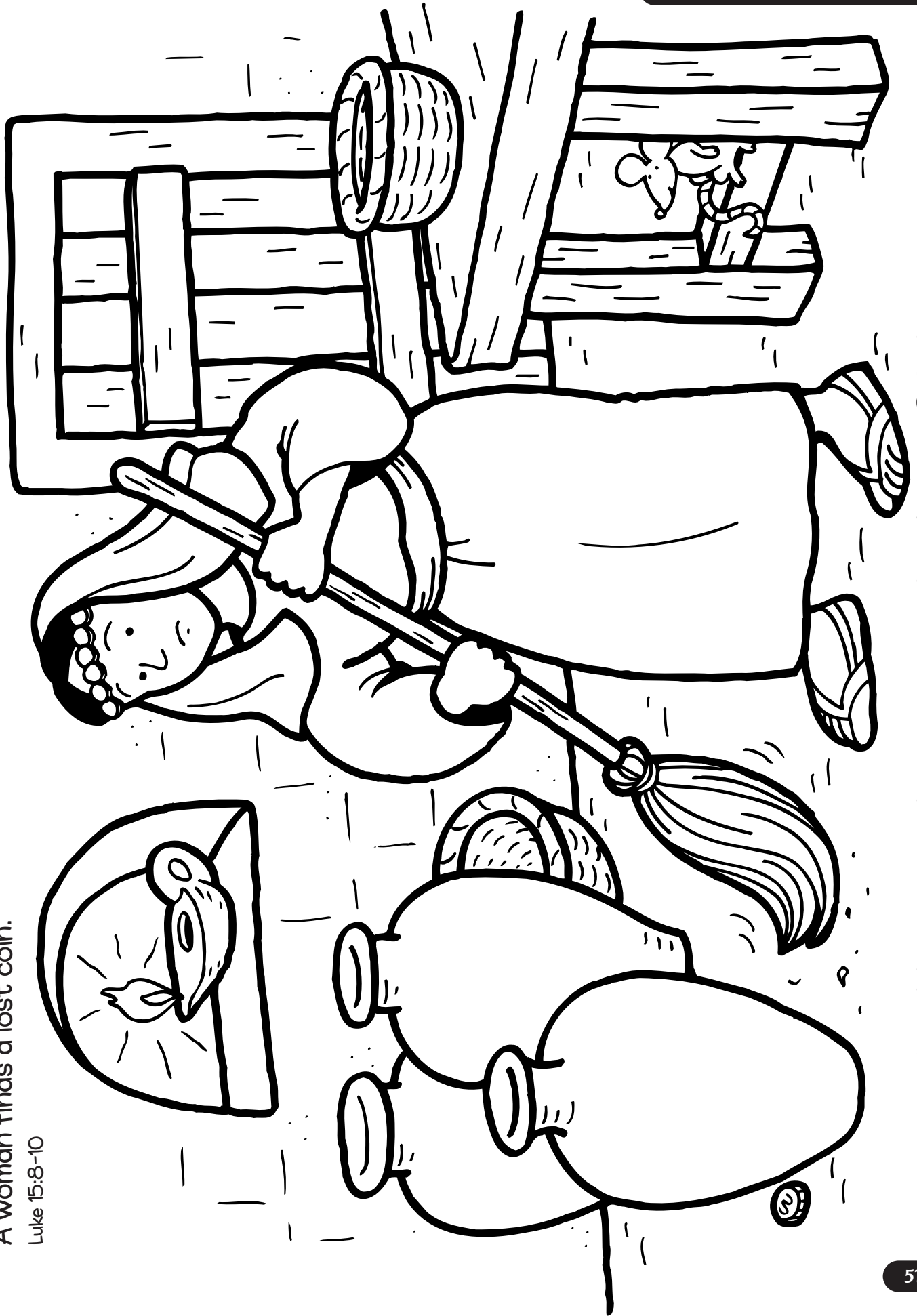

What did the woman do when she found the lost coin? God is even MORE glad when we love Him and become part of His family.

PARTY BALLOONS!

It's party time! And every balloon holds letters to unscramble. Write them in order below to find out why we're partying!

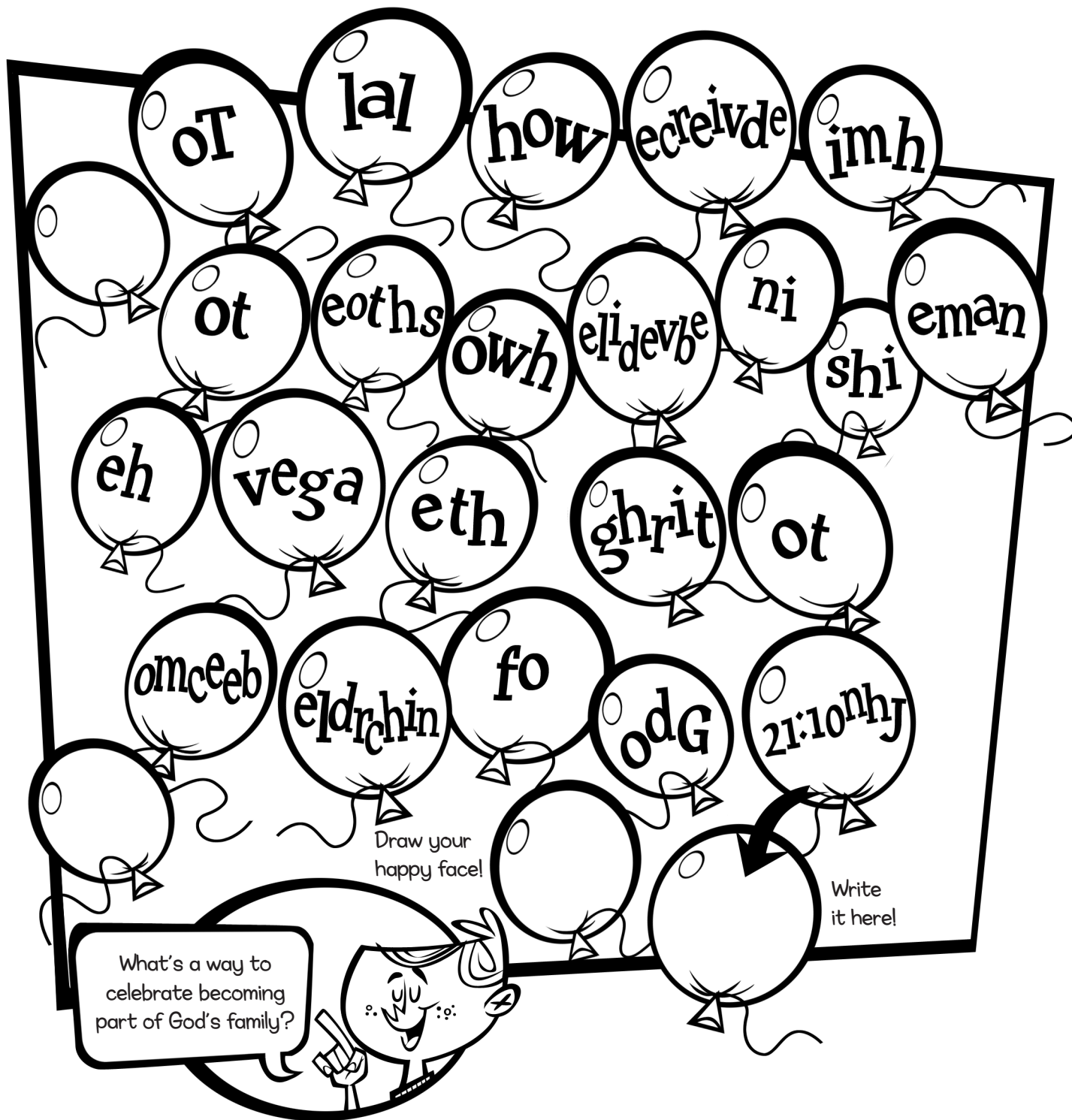

“ _____ , _____
_____ , _____
_____ .”

SALT AND LIGHT

MATTHEW 5:13-16



**SHINE
YOUR LIGHT**

TEACHER'S DEVOTIONAL

What qualities of salt and of light can you quickly list? We are so connected to salt and light, it may be hard to think about life without them! But without light, there can be no life on Earth; without salt, our lives cannot flourish. A light burning brightly in a closed-up closet is worthless. Salt that sits in a shaker has no value—for both light and salt have value only when they are used! Is this not the very reason that Jesus called His followers “light” and “salt”? God doesn’t need Christians who are content to be items in a spiritual museum—no, He made us to *be* salt and light so that we will “salt” and “light” those places where He put us! (Notice that “salt” and “light” are both noun and verb!)

So what does it look like to salt and light our world? Kind deeds and words, like salt, preserve, heal, purify and flavor. Merciful and truthful words and actions, like light, cause darkness to flee, bring warmth and make the path clear. When God’s love motivates an action, lasting good is accomplished. And the best news for us “salt and light people” is that we can come to our Father God and gain power from the source for all loving acts! Ask His Spirit to draw you deeper into a love relationship; seek His Kingdom first—you’ll discover that He then does through you good things that make people see and glorify Him (not you!).

This is also the way in which the kids you teach will understand what it means to be salt and light—by watching your life! Be sure they also understand that they can be salt and light: As kids show God’s love, even the smallest act of kindness has powerful results!

GOD’S WORD

“Let your light shine before men, that they may see your good deeds and praise your Father in heaven.”

Matthew 5:16

FOR YOUNGER CHILDREN:

“Do good things to show God’s love.”

GOD’S WORD & ME

Our everyday actions of love and obedience to God show others who God is.



PLANNING PAGE

Choose which centers you will provide and the order in which children will participate in them (see pp. 14-18 for schedule tips and pp. 24-25 for guidelines in combining older and younger children). Also plan who will lead each center (for staffing tips see pp. 19-21). Use the reproducible planning sheet (p. 238) to record your plans.

BIBLE STORY CENTER

BIBLE STORY

Salt and Light • Matthew 5:13-16

ADVENTURE BOX (YOUNGER CHILD)

Use props (salt shaker, a small flashlight and a large bowl) to demonstrate story action

ADVENTURE BOX (OLDER CHILD)

Use props (salt shaker, either a small flashlight or a candle and matches, and large ceramic bowl) to demonstrate story action

ART CENTER

YOUNGER CHILD OPTION

Make star rubbings and talk about what it means to shine like stars when we love and obey God

MATERIALS

Bible; star-shaped cookie cutters; pencil; cardboard; scissors; construction paper; unwrapped yellow, orange and red crayons

OLDER CHILD OPTION

Make sun-catchers and talk about how people who love and obey God are like light

MATERIALS

Bible, scissors, 2-inch (5-cm) squares of tissue paper in a variety of colors, glue sticks, hole punch; for each child—9-inch (23-cm) black construction paper square, 9-inch (23-cm) waxed paper square, 18-inch (45.5-cm) length of ribbon

GAME CENTER

YOUNGER CHILD OPTION

Play a game to collect cards picturing different kinds of light and tell ways to do good things and obey God

MATERIALS

Bible, Lesson 2 Pattern Page (p. 70), scissors

OLDER CHILD OPTION

Repeat the words of Matthew 5:16 while playing a game with rainforest catchers

MATERIALS

Bible, stapler, glue, aluminum foil; for each child—two colorful paper plates, colorful paper bowl

COLORING/PUZZLE CENTER

YOUNGER CHILD OPTION

Review the Bible story while completing coloring page

MATERIALS

Lesson 2 Coloring Page (p. 71) for each child, crayons

OLDER CHILD OPTION

Review ways of obeying Matthew 5:16 while completing puzzle page

MATERIALS

Lesson 2 Puzzle Page (p. 72) for each child, pencils

WORSHIP CENTER

FOR THE YOUNGER AND OLDER CHILD

Participate in large-group activities to review Bible verse and to worship God together

MATERIALS

Bibles, *Parable Quest* CD-ROM and CD player, song charts (pp. 246, 253), balloons, one or more large garbage bags, permanent markers, several flashlights

BONUS THEME IDEAS

Bonus Theme Ideas can be used at any time during this session: as an additional activity center, to extend the session for a longer time, or for added theme excitement.

WALK INTO THE RAINFOREST

Add an atmosphere of adventure to the room where children gather for *Parable Quest*. Use one or more of these ideas: (1) Make drops of water or cut streamers from shiny, iridescent paper and hang from doorway; (2) Lay inexpensive blue plastic tablecloths at the entrance for a river through which children must walk; (3) Just for fun, at the beginning of one session set out an inflatable wading pool filled with several inches of water through which children walk barefoot and then onto several beach towels; (4) Play "Rainforest Sounds" from CD-ROM.

Post a note alerting parents to the use of food. Also, check registration forms for possible food allergies.



RAINFOREST TREATS

Collect bananas, plastic knives and spoons, chocolate chips, disposable bowls, plates and napkins. Cut each banana in half and place chocolate chips in several bowls. Give each child a banana half, plate, plastic knife and napkin. **Let's make a treat with two foods that grow in the rainforest.** Child peels banana and then slices it in half lengthwise. Child uses spoon to create a long "ditch" in the banana (see sketch). Be ready to help as needed. Child uses spoon to place chocolate chips into the ditch and then eats this tasty rainforest treat. (Optional: Provide whipped cream for children to add to snack.)



COLORS OF THE RAINFOREST

Before class, collect red and blue food coloring, spoon, vegetable oil, tablespoon, bowl made of clear glass and water. (Optional: Collect a set of supplies for groups of four children each.) **In the rainforest we can see many birds and flowers with brilliant colors. Let's try an experiment with colors.** Stir two drops each of red and blue food coloring into one tablespoon of vegetable oil until food coloring breaks up into little drops. Fill bowl with water and pour food coloring mixture into it. Have children watch to see how the colored drops slowly sink and mix with the water to form color bursts.

BIBLE STORY CENTER

FOR YOUNGER CHILDREN • MATTHEW 5:13-16

INTRODUCTION

Welcome your rainforest explorers by asking them all to pretend to be parrots squawking to say hello to each other. Then show Adventure Box. **What do you think is in our Adventure Box today? Let's find out!** Untie box. Remove items from box and use them to demonstrate story action as you tell the story.



ADVENTURE BOX

In a cardboard or wooden box labeled "Adventure," place a Bible and these props: salt shaker, small flashlight and large bowl. Tie rope or brown yarn around the box or crate.

TELL THE STORY

One day, Jesus was sitting outdoors with His friends. He was teaching His friends about God. Jesus and His friends were sitting on the side of a big hill. Many, many people were listening to hear Jesus' words. Jesus was telling His friends about the good things God does, even when things are hard and it seems like there is lots of trouble.

Then Jesus said a very surprising thing to His friends! He said, "You are like salt! Now, if salt isn't salty anymore, it's not good. It doesn't help your food. It's not good for anything!" *(Show the salt shaker. With child's permission, sprinkle a little salt in each child's hand for child to taste.)*

If we make a recipe of cookies and forget to put in the salt, the cookies don't taste good. So when Jesus talked about His friends being salt, He meant that people who love God make the world better, just like salt makes food better. When we show God's love to other people, it is a good thing, like putting salt on food is a good thing. When we are kind and care about people, we show God's love. It makes everything better!

Next, Jesus talked about light to His friends. He said, "You are the light of the world. You are like a city that is up on a hill." If a city is up on a hill, everyone can see its bright lights at night. It makes the darkness go away! *(Turn on flashlight and shine it on ceiling.)*

Then Jesus said, "If you had a light in your hand and you needed to use it to see, would you put the light under a bowl?" *(Invite child to hold bowl upside down over the light.)* Of course not! A light is made to shine! So you don't try to hide it. You use it to see!

"If you have a light," Jesus said, "you put it up high! That way, it helps everyone in the house to see at night!" *(Remove bowl and shine flashlight around the room.)*

But Jesus wasn't finished. He went on, "Showing God's love by doing good things is just like shining a light. When you do good things, people see God's love coming from you. Then they will be glad about God and will praise Him!"

Being kind shows God's love like a flashlight shows light in a dark place. When people see the kind things you do, it shows them more about who God is. That is the way you can be like a light.

GOD'S WORD & ME

Jesus said that people who love God are as important as salt and light. We're important because when we love God, we do good things. That helps other people learn to love God, too. The Bible says, "Do good things." Every day we can do good things like tell the truth and help people. Pray, Dear God, thank You for each person here today. Help us do good things every day. In Jesus' name, amen.



SHINE
YOUR LIGHT

BIBLE STORY CENTER

FOR OLDER CHILDREN • MATTHEW 5:13-16

INTRODUCTION

Introduce the story by leading children to play a game of Charades. To play the game, secretly tell a volunteer the name of an item that uses light (flashlight, lamp, searchlight, candle, laser pen light, light switch, etc.). Volunteer acts out the use of the item for others to guess. Repeat with additional items. **What was the same about each of our charades? That's right. They were all about light! We use light all of the time, so we know how important it is. Today we're going to find out why Jesus compared some people to light.**

What do you think is in our Adventure Box today? Let's find out!

Untie box. Remove items from box and use them to demonstrate story action as you tell the story.



ADVENTURE BOX

In a cardboard or wooden box labeled "Adventure," place a Bible, and one or more of these props: salt shaker, small flashlight, large bowl. Tie rope or brown yarn around the box or crate. (Optional: Instead of flashlight and large bowl, put a candle, matches and ceramic bowl in the box. Ahead of time, print a nighttime map from the Internet and bring it to class.)

TELL THE STORY

One day, Jesus was outdoors with His friends. Crowds and crowds of people were milling around, waiting for Jesus to begin teaching them. So Jesus walked a little way up the side of a mountain so that when He spoke, everyone could hear Him. He began teaching His friends about God's Kingdom. The crowds of people down below were probably very quiet, straining to catch every word Jesus said!

Jesus began by telling His friends how they could be part of God's great Kingdom. He talked about the good things God does, even when things are hard and it seems like there is lots of trouble.

Jesus said, "Even when people say bad things about you because you love and obey Me, be glad! People saying bad things about you only means that you can expect good things to come to you in heaven. Remember, people said bad things about God's messengers long ago. They didn't like to hear the truth about God from the prophets, either. You are in good company!"

Then Jesus said something very surprising! He said, "You are the salt of the earth!" What do you think Jesus meant by that? *(Show the salt shaker. Children pass shaker and sprinkle a little salt in hand to taste if desired. Invite children to tell how salt tastes.)*

Jesus continued, "Now, if salt doesn't taste like salt—if it isn't salty anymore—then what is it good for? Salt that isn't salty won't make your food taste better. It won't clean your sores. It won't even help to keep your fish from spoiling. Un-salty salt isn't good for anything!" *(Invite children to tell other uses of salt.)*

Jesus meant that people who are part of God's Kingdom and members of His family show His love to others by doing things that make the world around them better. God's love, like salt makes things clean. It keeps things from going bad and makes things better, just like adding salt to food makes the food better or putting salt all over fish keeps it from spoiling. When we show God's love to other people, what we do changes things. Those acts of love and obedience to God make a big difference—just like salt does!

Next, Jesus said, "You are the light of the world. You are like a city that is built on the top of a hill." *(Light candle or hold flashlight.)* If you see a city is on a hill at night, how does the sky look? If a city on a hill is lit up at night, everyone can see its bright lights. Now that we have electric lights, there a glow in the sky wherever there is a city!

(Optional: Show nighttime map of the world.)

Then Jesus said, "If you had a light in your hand and you needed it to see, would you put the light under a bowl?" *(Invite student to hold bowl down over the light.)*

Of course not! A light is made to shine! So you don't try to hide it. You use it to see! *(Remove bowl.)*

"If you have a light, you place it where everyone in the house can use it to see!" (*Stand with candle or flashlight in a dark spot in the room.*)

But Jesus wasn't finished. He went on, "When you show God's love by doing good things, it is just like shining a light. When you do good things, people see God's love coming from you. They will understand more about who God is. They will be glad for what you did, but they'll see that it came from God—and they will praise Him!"

GOD'S WORD & ME

Sometimes we are kind or patient or helpful because we want people to like us. But there is a more important reason to act in these good ways—it's because we love God! And we can show others God's love in the same way as the flashlight shines light in a dark place.

When people see us being kind, they notice that there is something—or Someone!—behind such kindness. When we show God's love and obey Him, it helps others understand more about who God is. By God's power, you can make a difference in our world—being like salt and like light!

- **What are some ways salt or light change things?**
- **How are our actions like light? How did Jesus answer this question?** Invite a student to read aloud Matthew 5:16. **Jesus said that the things we do and say every day can be like a light that shines and shows others more about who God is.**
- **What are some right actions a kid your age can do?** (Tell the truth when you're about to get in trouble. Be kind to a kid no one else likes.) Pray with children, asking God to help them show their love and obedience to Him in their everyday actions so that others learn about God.



GAME CENTER

FOR YOUNGER CHILDREN • MATTHEW 5:13-16

COLLECT

Bible, Lesson 2 Pattern Page (p. 70), scissors; optional—markers.

PREPARE

Photocopy at least two Pattern Pages. Cut apart to make a set of matching game cards. (Make a set for each group of five or six children.)

DO

1. Children line up at one side of open play area, forming teams of five or six children each. Place game cards facedown across the room from the play area.
2. Children take turns running across the room to collect a game card. As game cards are collected, team members place matching cards together. Continue until all cards have been matched.
3. Repeat game as time and interest allow, changing the way in which children move across the room each time (jump, walk backwards, skip, etc.).

TALK ABOUT

- At night, we can see the light from the stars. In our Bible story today, Jesus talked about light. We need light to see what to do. Jesus said that the people who love God are as important as light. People who love God do good things.
- When we played our game today, I saw you taking turns. That's a good thing to do. When are some other times you and your friends can take turns? (Playing with toys. Riding a scooter.)
- The Bible says, "Do good things." When we do good things, we show that we love God. We help other people learn about God. They can learn what God wants them to do.
- One good thing we can do is pray. Pray briefly, Dear God, please help us do good things every day. We love You and we want other people to love You, too. In Jesus' name, amen.

FOR OLDER CHILDREN

Before running to collect a card, child repeats Bible verse. (Optional: Photocopy each team's set of cards on a different color of paper. Before class, hide cards around classroom. Team members take turns hunting for cards. When a card is found, team member returns to team and next player takes a turn. Team who collects complete set of cards first wins.)

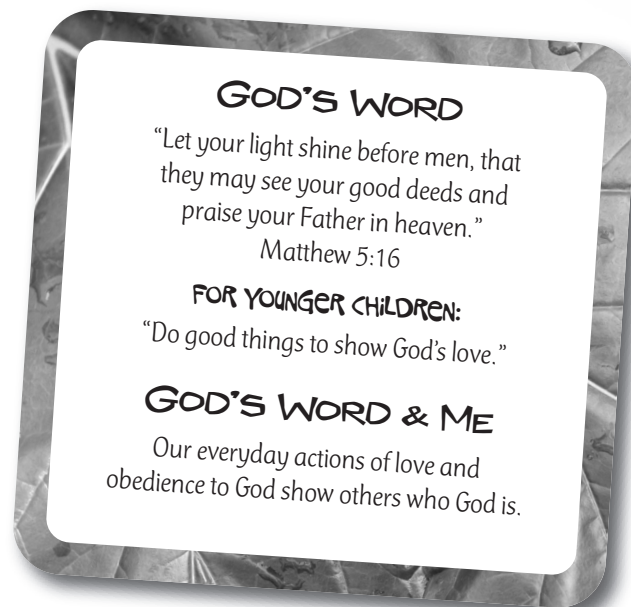

GAME CENTER

FOR OLDER CHILDREN • MATTHEW 5:13-16

COLLECT

Bible, stapler, glue, aluminum foil; for each child—two colorful paper plates, colorful paper bowl.

PREPARE

Make a rainforest catcher for yourself and each student. Staple the edges of two paper plates together with tops facing in, leaving an opening on one side. Glue a paper bowl to one plate. Set aside to dry.

DO

1. **In the rainforest, supersized flowers and leaves catch the rain that falls. We're going to play a game today where we use rainforest catchers.** Crumple up a piece of aluminum foil, toss it up in the air and try to catch it while wearing the catcher (see sketch). Give each child a catcher and foil and let them make foil balls and practice tossing and catching the balls.

2. Collect foil balls. Children form a circle. As you toss the ball to any child in the circle, lead children in saying the first word of Matthew 5:16. Child catches ball and tosses it to another child in the circle, while everyone says the second word of the verse. Continue until entire verse has been quoted.

3. Optional: Child who catches foil ball when the word "deeds" has been said, tells an action that is an example of a way he or she can show obedience to God in everyday life.

TALK ABOUT

- **What are some ways you need light every day? Matthew 5:16 says that when we obey and love God by doing good things, it's like we are light. We help others see God and learn who He is.**
- **What are some examples of good actions that you think would make your school a better place to be?** (Telling the truth. Not making fun of others. Treating others with patience.)
- **When is a time someone you know has been like light because he or she obeyed God? What did the person do?** (My older sister was patient and didn't get mad when I accidentally broke her CD.)
- **Think of one place you go every week. Now think of a good action you can do or something good you can say to let your light shine.** Lead children in prayer, asking God to help them show others who God is.

FOR YOUNGER CHILDREN

Instead of making catchers, set out eight bowls in two rows. Children take turns telling the names of people whom they can treat in good ways or telling good things they can do to obey God before tossing foil balls into bowls. Allow children to stand as close to the balls as needed in order to be successful in tossing balls into the bowls.

GOD'S WORD

"Let your light shine before men, that they may see your good deeds and praise your Father in heaven."

Matthew 5:16

FOR YOUNGER CHILDREN:

"Do good things to show God's love."

GOD'S WORD & ME

Our everyday actions of love and obedience to God show others who God is.

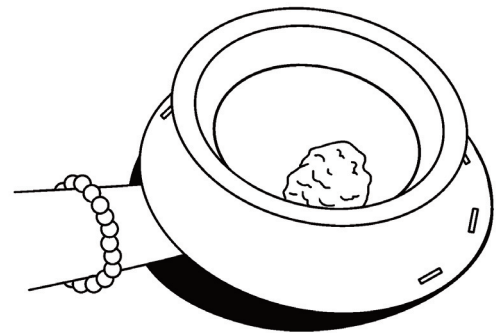

ART CENTER

FOR YOUNGER CHILDREN • MATTHEW 5:13-16

COLLECT

Bible; star-shaped cookie cutters; pencil; cardboard; scissors; construction paper; unwrapped yellow, orange and red crayons; optional—tape, die-cut stars, star shapes cut from sandpaper and/or loosely-woven cloth.

PREPARE

Trace around cookie cutters to make at least a dozen cardboard star shapes in a variety of sizes.

DO

1. Child places a star shape under a sheet of paper and rubs over the shape so that the design of the star appears on the paper. (Optional: If children have difficulty holding shapes securely, tape the shape and/or paper to the table while child completes the rubbing.)
2. Encourage children to make rubbings of a variety of stars, placing the star shapes to create an interesting design.

TALK ABOUT

• At night, we can see the light from the stars. In our Bible story today, Jesus talked about light. We need light to see what to do. Jesus said that the people who love God are as important as light. People who love God do good things.

• What is a good thing someone in your family does to help you? (Plays with me. Helps me learn to ride a bike.) What is something good you can do to help someone else? (Share a favorite snack. Do a chore without complaining.)

• The Bible says, “Do good things to show that you love God.” When you help someone, you are doing good. Who is someone older than you to help? Who is someone younger than you to help? Briefly pray, including the names mentioned by children and asking God’s help in obeying Him.

FOR OLDER CHILDREN

Provide children with lightweight cardboard and let them cut out their own shapes to use in making rubbings. Children may make shapes that represent items they can use in doing good.

GOD’S WORD

“Let your light shine before men, that they may see your good deeds and praise your Father in heaven.”

Matthew 5:16

FOR YOUNGER CHILDREN:

“Do good things to show God’s love.”

GOD’S WORD & ME

Our everyday actions of love and obedience to God show others who God is.



ART CENTER

FOR OLDER CHILDREN • MATTHEW 5:13-16

COLLECT

Bible, scissors, 2-inch (5-cm) squares of tissue paper in a variety of colors, glue sticks, hole punch; for each child—9-inch (23-cm) black construction paper square, 9-inch (23-cm) waxed paper square, 18-inch (45.5-cm) length of ribbon.

DO

1. Give each child a sheet of black paper. Child folds paper in half two times and then folds the square into a triangle (see sketch a). Child cuts several shapes from each of the folded sides and opens the paper.
2. Child glues tissue paper squares onto waxed paper, creating a design of his or her own choosing, and then glues the black frame on top of the waxed paper sheet.
3. Child punches hole in top of frame, inserts ribbon and ties to make a hanger (see sketch b). Child hangs sun catcher in window in classroom or at home.

TALK ABOUT

- **What might our world be like if there was no light?** (Plants and trees wouldn't grow. We would not be able to see.)
- **In our Bible story today, Jesus told how important light is. Light helps us see where we are going. Why did Jesus say that people who love and obey God are like light?** (When people obey God, their actions show who God is. Their actions and words help people "see" or learn about God.)
- Read Matthew 5:16 aloud. **What does this verse say is the result of our actions when they show love and obedience to God?** (People praise and thank God.)
- **What good action would you like God to help you show to others this week?** Tell your own answer to this question before leading children in prayer, asking God's help in acting like light.

FOR YOUNGER CHILDREN

Instead of making frames, children simply glue tissue paper squares onto waxed paper. Punch papers and let children insert ribbon. Tie ribbon to make hangers.

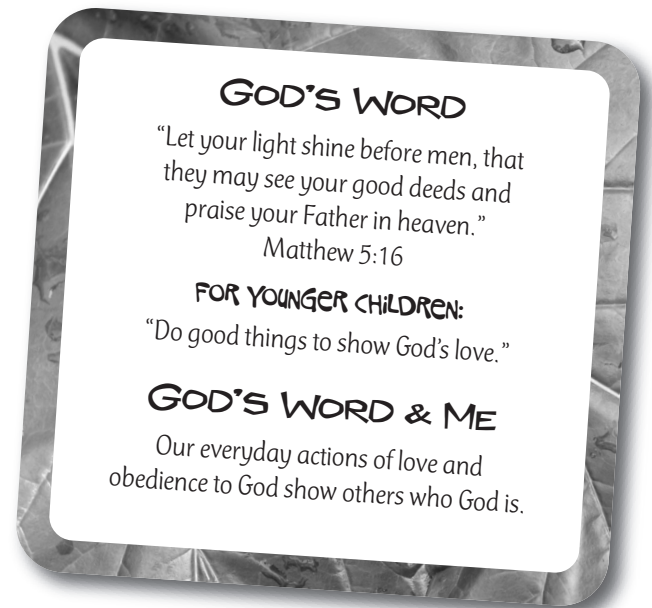

a.

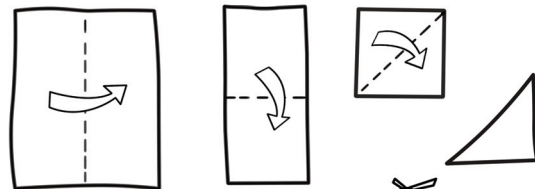

b.

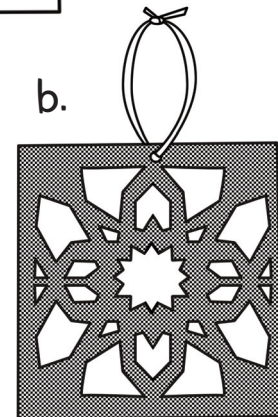

WORSHIP CENTER

MATTHEW 5:13-16

COLLECT

Bibles, *Parable Quest* CD-ROM and CD player, song charts (pp. 246, 253), balloons, one or more large garbage bags, permanent markers, several flashlights.

PREPARATION

Blow up a balloon for each child plus a few extras. Place balloons in garbage bag(s).

TEAM GAME

Give each child a balloon. Children take turns using markers to write their names on the balloons. Be ready to help children if needed. (Optional: Each child also writes on the balloon one word that tells a favorite sport, book, game or food.) Children stand holding balloons. Play "Name to Come Song" and invite children to begin batting their balloons around the room. If space is limited, have children pass balloons from one to another. After 5 to 10 seconds, stop the music. Each child holds one balloon and sits down. Children take turns reading aloud the names on the balloons. As each name is read, the named person stands up and high fives you or another nearby leader. Continue until each child has been introduced.

BIBLE VERSE GAME

Give flashlights to several children. Say Matthew 5:16 aloud with children. Children holding flashlights turn them on when the words "light," "shine," "see" and "praise" are said. Pause after each of these words is said so that children can turn on and then off the flashlights. Repeat verse several times, letting other children use the flashlights.

SONG

You, or another leader, lead children in singing "Salt," adding motions and/or clapping if desired.

PRAYER

Think of one way you are already letting your light shine and obeying Matthew 5:16. Then think of one way you would like to start obeying this verse. Briefly tell your answers before inviting kids to pray silently or aloud. Lead children in a closing prayer, thanking God for His help in obeying.

SONG

You, or another leader, lead children in singing "Following Jesus," adding motions and/or clapping if desired.

GOD'S WORD

"Let your light shine before men, that they may see your good deeds and praise your Father in heaven."

Matthew 5:16

FOR YOUNGER CHILDREN:

"Do good things to show God's love."

GOD'S WORD & ME

Our everyday actions of love and obedience to God show others who God is.

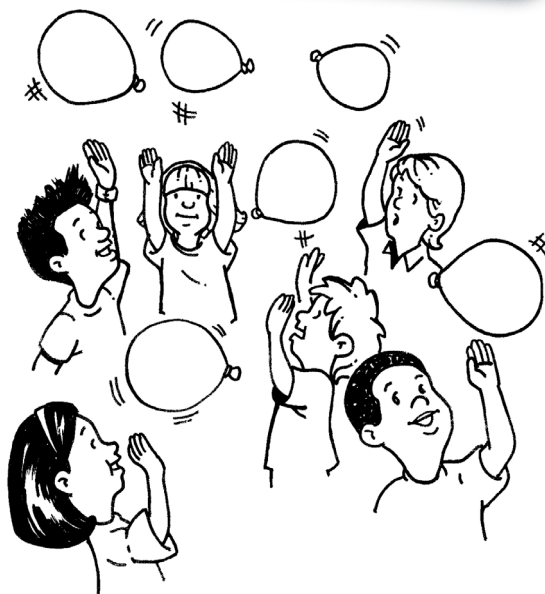

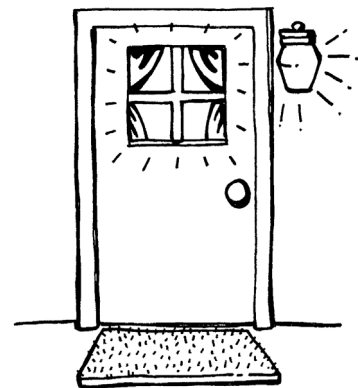
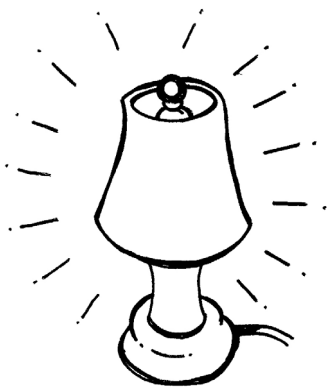
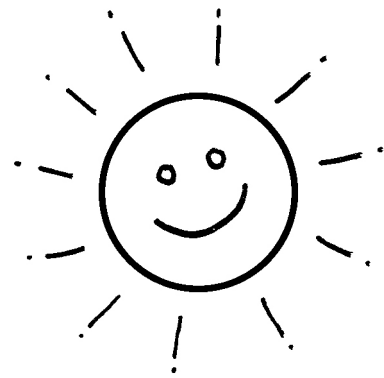
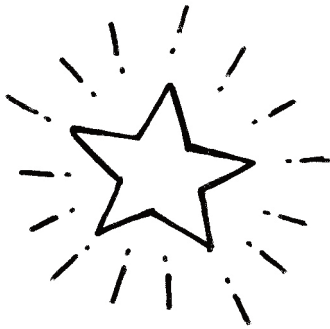
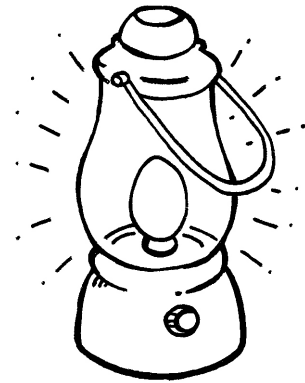
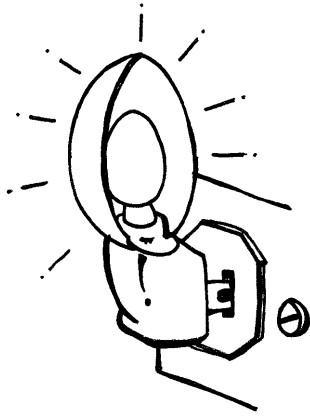
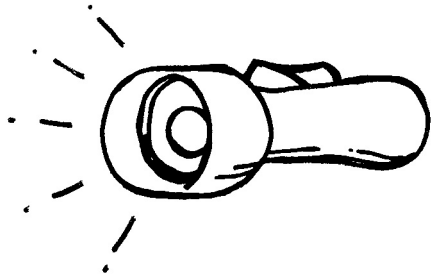

Jesus tells about
salt and light.
Matthew 5:13-16

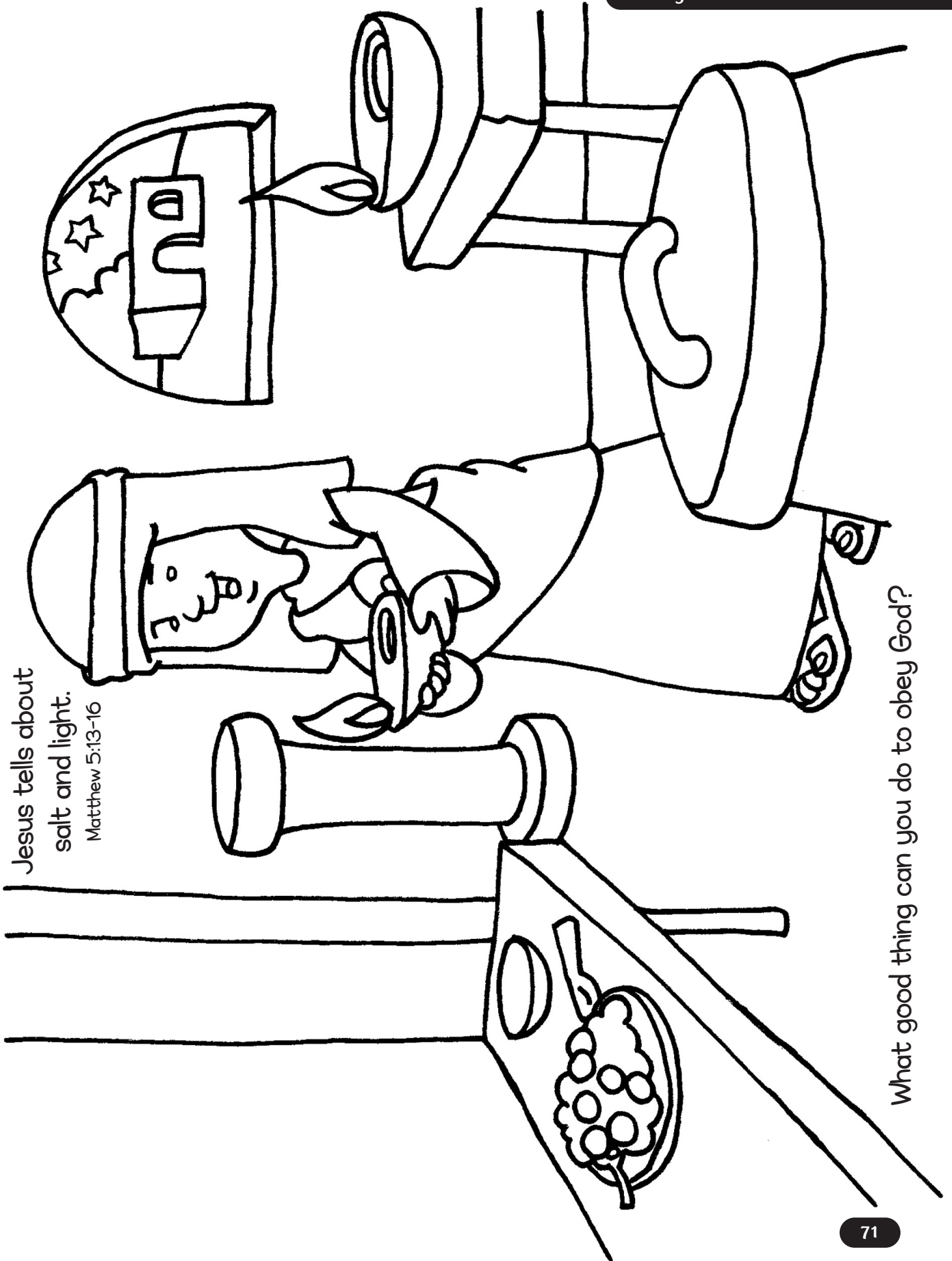

What good thing can you do to obey God?

SHINE EVERY DAY!

Help Reuben and Rachel move through the maze—and through every box!

Tip #1: There may be more than one path!

Tip #2: It's OK to go "under" paths!

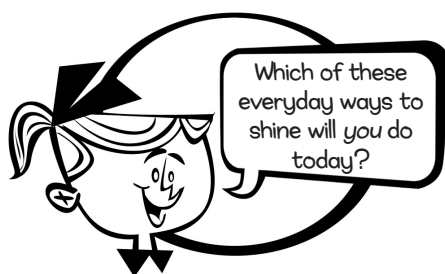

You're a shiner!

SHINE!

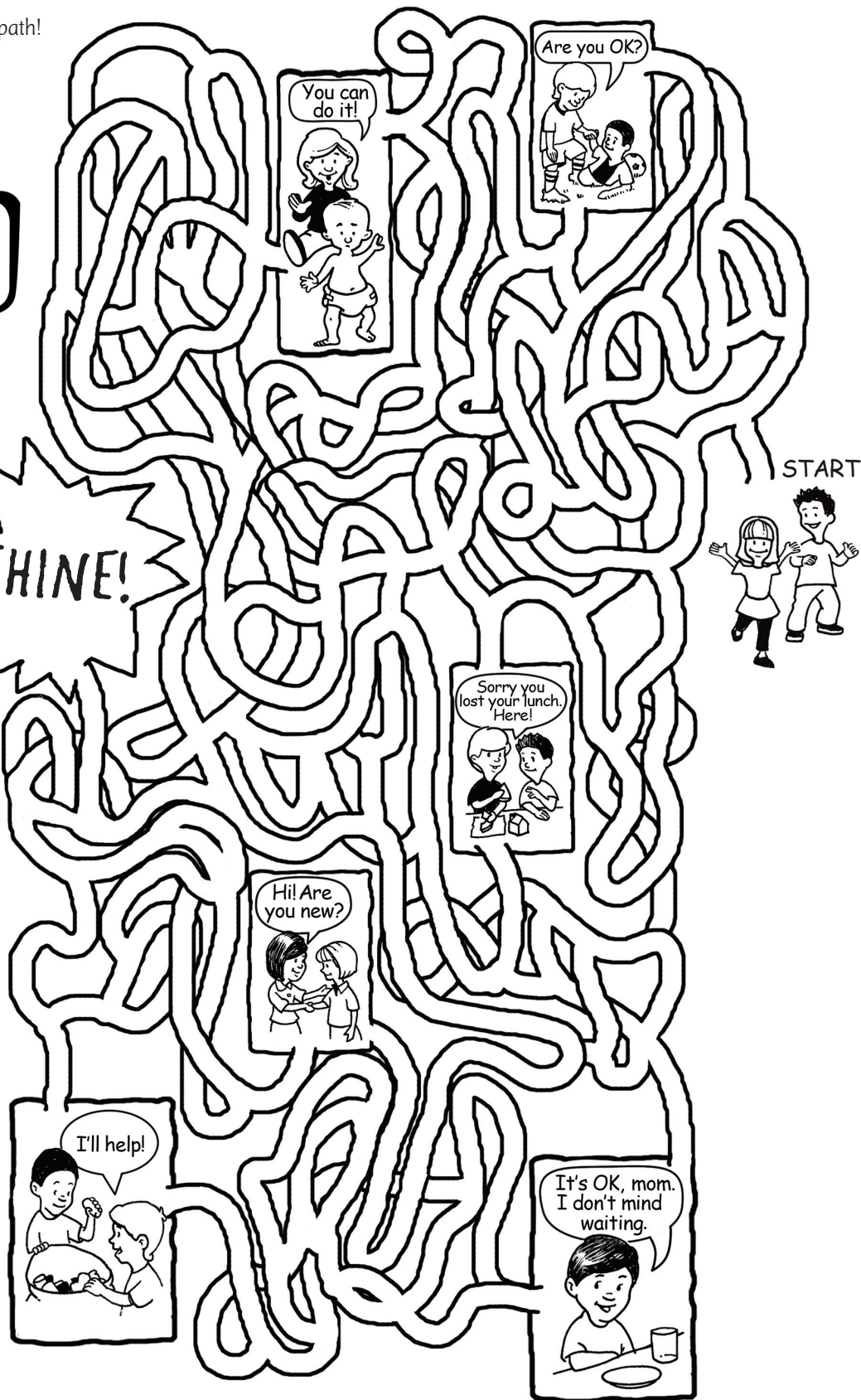

Wise and Foolish Builders

MATTHEW 7:24-27



**OBEY THE
WORD**

Teacher's Devotional

Can you name three ways in which information technology has changed your life in the past few years? Searching the Internet is now so common that “to google” has become a verb. Access to news and information is available even on our phones. We can talk with nearly anyone, anywhere. There’s an expert readily available for nearly any project! Although information is now easy to gain, wisdom is still more rare: No matter the technology, only God’s Word even begins to give us the foundation of wisdom we need!

To help yourself and your kids hone in on the powerful and vital truths of God’s Word, take stock of your own “Bible information highway.” In what life situations have Bible stories or verses carried you through difficult days? Guided you when there seemed no path? What new understandings have you gained recently through this “living and powerful” book? Write them down—they’re important!

While the children in your class vary in their skill levels, they are all moving toward mastery of reading and comprehension (even if they never read actual paper-and-ink books). Of all the information to which they have access, they mainly need the firm foundation the Bible has to offer them. It’s more than information; it is the key to transformation! Take this opportunity to fan the flame of love for God’s Word. Tell about times and ways in which His Word has shown you how to deal with a problem. Invite them to tell favorite verses or stories and about times when God used His Word to help them. Pray that the Holy Spirit will use this time to stir up love—both yours and your children’s—for God’s Word, love that motivates us to build our lives on the rock of His truth!

GOD’S WORD

“Do not merely listen to the word, and so deceive yourselves. Do what it says.”

James 1:22

FOR YOUNGER CHILDREN:

“Obey God’s Word.”

GOD’S WORD & ME

The way to have wisdom and confidence is to obey God’s commands.

PLANNING PAGE

Choose which centers you will provide and the order in which children will participate in them (see pp. 14-18 for schedule tips and pp. 24-25 for guidelines in combining older and younger children). Also plan who will lead each center (for staffing tips see pp. 19-21). Use the reproducible planning sheet (p. 238) to record your plans.

BIBLE STORY CENTER

BIBLE STORY

Wise and Foolish Builders • Matthew 7:24-27

ADVENTURE BOX (YOUNGER CHILD)

Use props (flat rock, rectangular cake pan containing a shallow layer of sand, a small box or a toy house, cup of water) to demonstrate story action

ADVENTURE BOX (OLDER CHILD)

Children use props (flat rock, rectangular cake pan containing a shallow layer of sand, a small box or a toy house, cup of water) to demonstrate story action

ART CENTER

YOUNGER CHILD OPTION

Make "rain" pictures to talk about the Bible story and tell ways to obey God's Word

MATERIALS

Bible, white card stock, plastic tablecloths, washable markers, several spray bottles filled with water

OLDER CHILD OPTION

Draw chalk pictures of Bible story events and talk about times to obey God's Word

MATERIALS

Bible, broom, sidewalk chalk, several cups of water

GAME CENTER

YOUNGER CHILD OPTION

Follow instructions while walking on a large house shape and talk about ways to follow instructions in the Bible

MATERIALS

Bible, masking tape, rain stick or rhythm instrument

OLDER CHILD OPTION

Play a game with rainforest "bugs" to review James 1:22 and talk about ways to obey God's Word

MATERIALS

Bible, Lesson 3 Pattern Page (p. 84), scissors, four flat rocks, markers, long length of yarn

COLORING/PUZZLE CENTER

YOUNGER CHILD OPTION

Review the Bible story while completing coloring page

MATERIALS

Lesson 3 Coloring Page (p. 85) for each child, crayons

OLDER CHILD OPTION

Review the Bible story while completing puzzle page

MATERIALS

Lesson 3 Puzzle Page (p. 86) for each child, pencils

WORSHIP CENTER

FOR THE YOUNGER AND OLDER CHILD

Participate in large-group activities to review Bible verse and to worship God together

MATERIALS

Bibles, *Parable Quest* CD-ROM and CD player, Lesson 3 Pattern Page (p. 84), song charts (pp. 248, 254), inflated balloon or ball, box or other container, scratch paper

BONUS THEME IDEAS

Bonus Theme Ideas can be used at any time during this session: as an additional activity center, to extend the session for a longer time, or for added theme excitement.

COOL ORANGE BALLS

Mix together $1\frac{1}{8}$ cup crushed vanilla wafers, $\frac{3}{4}$ cup unsweetened coconut flakes, $\frac{3}{4}$ cup confectioners' sugar and 3 ounces (90 ml.) thawed orange juice concentrate. Place $\frac{1}{3}$ cup confectioners' sugar into several disposable bowls. Children wipe hands with disposable wipes. Give each child a $\frac{1}{2}$ cup of the mixture. Children form 1-inch (2.5-cm) balls and roll balls in the confectioners' sugar before eating these treats made with foods from the rainforest (orange, vanilla, coconut).

Post a note alerting parents to the use of food. Also, check registration forms for possible food allergies.



RAINFOREST MURAL

Using sidewalk chalk, children draw large rainforest scenes (vines, trees, river, animals, etc.) on sidewalk or blacktop area in church playground area. If going outdoors is not an option, children may draw scenes on butcher paper tape to floor.

MAKE YOUR OWN INSECT BUZZ

Provide a 9- to 11-inch (23- to 28-cm) balloon and a $\frac{1}{4}$ -inch (0.6-cm) hex nut for each child. Child places hex nut into the balloon, making sure nut is inserted all the way into the balloon. Blow up the balloon and tie it shut. (Adults blow up balloons for preschoolers.) Child holds onto the balloon and swings it around in a circle so that the hex nut rolls around the inside of the balloon. Listen up to the rainforest buzz!

BIBLE STORY CENTER

FOR YOUNGER CHILDREN • MATTHEW 7:24-27

INTRODUCTION

Welcome your rainforest explorers by asking them all to imitate you in making storm sounds (pat knees for rain, stomp feet for thunder, clap once for lightning, etc.). **In the rainforest, it is very wet and rainy. You all are very good at making rain sounds! What do you think our story might be about today? Then show Adventure Box. What do you think is in our Adventure Box today? Let's find out!** Untie box. Remove items from box and use them to demonstrate story action as you tell the story.



ADVENTURE BOX

In a cardboard or wooden box labeled "Adventure," place a Bible, a flat rock, a rectangular cake pan containing a shallow layer of sand and a small box or a toy house. Set a cup of water near you. Tie rope or brown yarn around the box or crate.

TELL THE STORY

One day Jesus told a story about building a house. He said, "A wise man built his house on a strong rock." *(Show cake pan. Move sand aside and then lay rock on pan. Set house on rock.)*

Then Jesus said a very surprising thing to His friends! He said, "Then the rain came. The winds blew! The water in the river came up higher and higher." *(Children make rain sounds, wind sounds and thunder sounds as you pour some water over house set on rock, shake pan slightly.)*

"All these things happened, but the house did not fall down. It did not fall down because it was built on strong rock. This wise man is like a person who listens to Me and obeys My words.

"But," said Jesus, "another man built a house. He was a foolish man." *(Pour water as needed onto sand. Invite children to feel wet sand in pan and then set house on sand.)*

Jesus went on. "This man was foolish because he built his house on the sand. But then, the rain came. The winds blew! The water in the river came up higher and higher." *(Children make rain sounds, wind sounds and thunder sounds as you pour more water over house on sand, shake pan slightly.)*

Jesus said, "The house on the sand FELL DOWN. That house wasn't built on something strong. The house is like a person who hears My words, but won't follow them. That person is like this foolish man."

Jesus told this story to help people learn how important it is to obey Jesus' words. Jesus' words are true and help people know the best way to live.

GOD'S WORD & ME

A person who listens to Jesus and does what He says is like the man who built his house on a big rock. The Bible tells us, "Obey God's Word." God's Word is like the big, strong rock. When trouble comes, we are safe if we believe and obey God's Word. We can read God's Word in the Bible. Pray, Dear God, thank You for the Bible. Please help us to listen and to obey Your Word. In Jesus' name, amen.



BIBLE STORY CENTER

FOR OLDER CHILDREN • MATTHEW 7:24-27

INTRODUCTION

Where do you think is the best place to live: the beach, the mountain, the country or the city? When I give the signal, if you would choose the beach, stand up and make waves with your hands. If you would choose the mountains, make a triangle with your arms and hands. If you would choose the city, stand and reach up high. If you would rather live in the wide-open country, spread your arms out to the side. Ready? Go! Remind children of actions as needed. Now look around—we can see who chose what, and we all look pretty funny! Today we'll hear a story Jesus told about choosing where to build a house!

What do you think is in our Adventure Box today? Let's find out! Untie box. Remove items from box and let children use them to demonstrate story action as you tell the story.

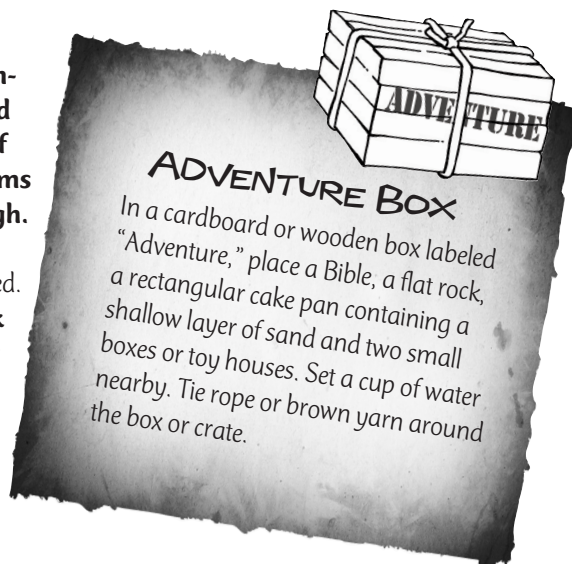

TELL THE STORY

While Jesus lived on Earth, He told His friends many important things about God. But sometimes those important things were hard for Jesus' friends to understand! So to help them understand what He was saying, Jesus would often tell His friends a story.

One of Jesus' stories, which are sometimes called parables, was about two men who built two houses.

(Show cake pan. Child moves sand aside and then lays rock on pan. Child sets one house on rock, smooths out sand and then sets other house on sand.)

Now both of these houses were just ordinary houses—they were pretty much alike, with mud walls and a roof made of sticks and grass and more mud. Both houses had windows and a door. The only thing that was different about these two houses was the PLACE each one was built.

One man decided to build his family's house on a beach beside a river. The land was flat and open. The soil was soft and sandy. It probably would be a good place for building sand castles whenever they wanted! To this man, it seemed like the perfect place to build a house!

The other man decided to build his family's house on a very big, flat rock near the river. It was not as easy as building a house on the low, flat sand. It probably took more work to drag the materials up onto that rock and more time to build. But the man had a good reason for building on the rock. **Why do you think he might have wanted to build his house on a rock?**

(Ask a volunteer to slowly begin to pour a little water over houses. Invite another volunteer to shake cake pan slightly.)

Soon both families were living in their houses. And both houses seemed to be fine. But then rain began to fall. It fell hard and steady for days and days. The wind blew and BLEW; in fact, the wind blew SO hard that it seemed as if the walls of those houses would fall right DOWN! When the water rose from all that rain, what do you think happened to the sandy soil? *(Invite children to touch wet sand.)*

Well, the sandy soil started to wash away down the river. The sturdy walls of the house had NOTHING to stand on! The family must have heard the walls groaning and creaking. Perhaps they ran outside just in time to see their new house go CRASH! SMASH! THUD!! And there was no more house—only a broken mess!

But the house built on the rock just SAT there during the entire storm—which is exactly what a house is SUPPOSED to do! You see, that rock wouldn't wash away when the storm came. It didn't slip or slide or crumble. It just stayed solid and firm! And because the rock was solid, that house stood and the family was protected!

Then Jesus explained, "A person who listens to Me and obeys Me is like that wise man who build his house on the rock. When trouble comes, that person won't fall apart, because he or she is protected. My Word is like a solid rock!"

"But someone who listens to Me and does NOT obey is like the foolish man who built a house on the sand. When troubles come to that person, his or her life will fall apart because it is not built on obeying the things I have told you."

Jesus told this story to help His friends learn how important it is to obey God's Word.

GOD'S WORD & ME

Listening to Jesus and obeying His Word are **STILL** important. Just like a house built on a big, strong, rock stays safe in a storm, obeying Jesus helps us stay safe when trouble comes. We can depend on Him to help us know what to do and to care for us when we have problems or worries. Paying attention to God's Word and obeying it helps us know the very best way to live.



- **What are some problems or worries a kid might have?** (Getting lost. Parents divorce. Not having friends at school.) **How might God's Word help a kid in those circumstances?** (Help him or her know what to do. Remind kid of God's promises and to pray to Him.)
- **What does James 1:22 say to do with God's Word?** Invite a child to read the verse aloud. **Why do you think the verse says, "Do not merely listen to the word, and so deceive yourselves. Do what it says"?** **Do you think some people were listening but not obeying?**
- **Think of a time when you can hear or read God's Word. Then think of a time you need God's help in obeying.** Pray with children, asking God to help them obey His Word and instead of hearing and forgetting it.



GAME CENTER

FOR YOUNGER CHILDREN • MATTHEW 7:24-27

COLLECT

Bible, masking tape, rain stick or rhythm instrument; optional—painter's tape in several colors.

PREPARE

Tape a large simple house shape on the floor, making each line at least 5 feet (1.5 m) long. Make a house shape for each group of eight children.

DO

1. Children line up near house shape and at your signal begin walking on the lines of the house. While children are walking, occasionally shake rain stick or rhythm instrument to represent the sound of rain. When children hear the "rain," they fall to the ground.
2. For each round, suggest a different way of walking on the lines: tip-toe, giant steps, squat and walk like a duck, turn sideways and walk, backwards and heel-to-toe.

TALK ABOUT

- Jesus told a story about two men who built a house. The story helps us know how important it is to follow the instructions in God's Word, the Bible. Let's follow some instructions in our game today.
- Ella, you are tiptoeing just like I said to do. Thank you. And you are being careful not to bump into Anna while you are walking. You are obeying God's Word when you are kind.
- The Bible says, "Obey God's Word." God's Word helps us know good things to do. Let's be kind and high five a friend on either side of us.
- Pray briefly, **Dear God, thank You for giving us the Bible. Please help us obey it. In Jesus' name, amen.**

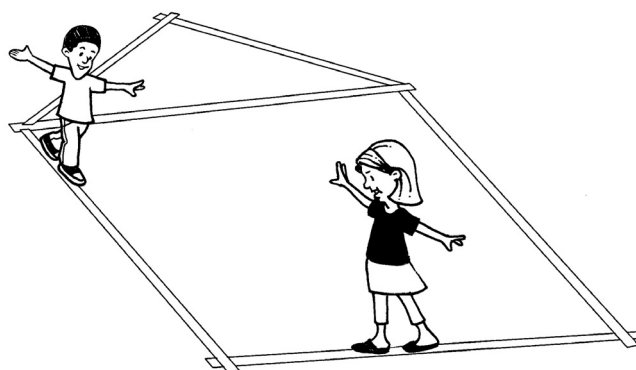

GOD'S WORD

"Do not merely listen to the word, and so deceive yourselves. Do what it says."
James 1:22

FOR YOUNGER CHILDREN:

"Obey God's Word."

GOD'S WORD & ME

The way to have wisdom and confidence is to obey God's commands.

FOR OLDER CHILDREN

Collect several beanbags and/or small balls. To play the game, children stand in different places on the lines of the house shape. Children toss beanbag or ball to each other, calling out numbers in order. Tell children to remember the numbers they called out. After repeating several times, call out "Mix up!" Children scramble to change places and then toss beanbag or ball again, following the same numbered order as before. Repeat several times. To create more challenge, add additional beanbags or balls.

GAME CENTER

FOR OLDER CHILDREN • MATTHEW 7:24-27

COLLECT

Bible, Lesson 3 Pattern Page (p. 84), scissors, four flat rocks, markers, long length of yarn.

PREPARE

Make two copies of Lesson 3 Pattern Page, making each copy on a different color of paper. Cut cards apart. To make rainforest "bugs," draw a line, face and dots on each rock, making one dot on two rocks and two dots on two rocks. (For more than two teams, make additional sets of cards and "bugs.")

DO

1. Children form two teams with up to eight children each and line up on one side of the room. Form a yarn circle near the teams. Place all verse cards across the room. Assign each team one color of cards and give each team two "bugs" (one with one dot and one with two dots).
2. At your signal, first player on each team tosses the rainforest bugs into the circle. Player adds up the number of dots showing. Player runs across the room, collects that number of verse cards and brings cards back to his or her team. As play continues, teams assemble cards in verse order. Game ends when both teams have assembled the cards correctly.

TALK ABOUT

- **In the game we played today, you needed to follow instructions. Why were you willing to follow these instructions?** (Wanted to finish the game.)
- **When might it be hard for kids your age to listen to instructions?** (They think they know what to do. They don't like others telling them what to do.) **When are some times bad things might happen if a kid listens to but doesn't follow instructions?** (Can't find an important book for school. Miss out on a party because can't find the right house. Get a bad grade on test because don't follow instructions.)
- **Our Bible verse today reminds us that the Bible, God's Word, is full of really important instructions for us to listen to AND obey.** Ask a child to read James 1:22 aloud. **What's the main idea of this verse?** (Listening to God's Word and doing what it says.)
- **What is something in the Bible you've read and obeyed?** Tell your own answer to this question. Lead children in prayer, thanking God for the Bible and asking His help in obeying. (Optional: Invite volunteers to tell specific instructions they need God's help to obey.)

FOR YOUNGER CHILDREN

Children play game by following your instructions to take turns tossing "bugs" into circle and counting the number of dots shown.

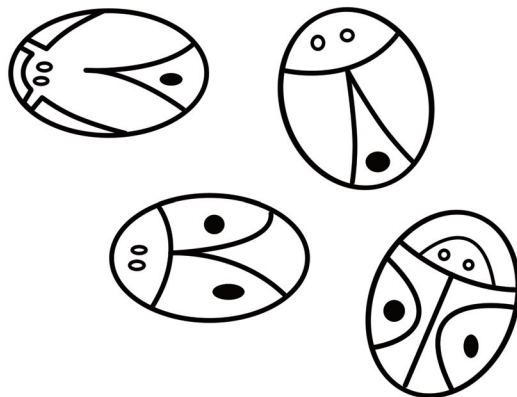
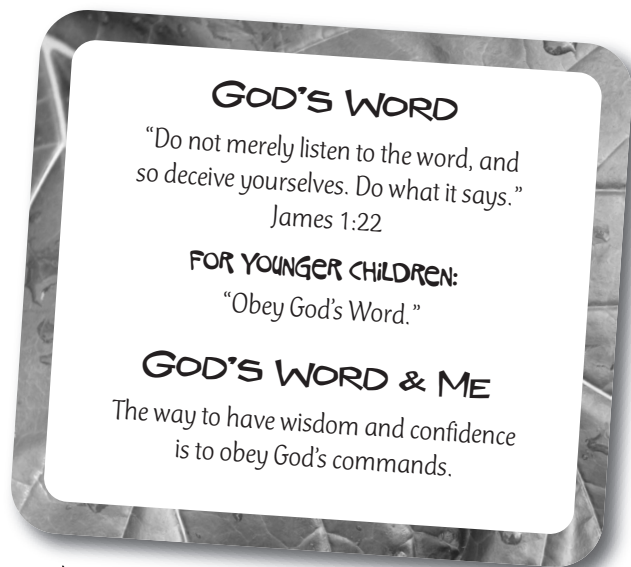

ART CENTER

FOR YOUNGER CHILDREN • MATTHEW 7:24-27

COLLECT

Bible, white card stock, plastic tablecloths, washable markers, several spray bottles filled with water.

PREPARE

Cover tables with plastic tablecloths.

DO

1. Give each child a sheet of card stock. Child draws picture or designs on card stock.
2. Children take turns using spray bottles to make "rain" fall on their papers. (Optional: Children spray papers outdoors.) Children observe how the colors run together to make interesting paintings.
3. Set aside wet paintings to dry.

TALK ABOUT

- **Let's make it rain on our pictures today! What good things can you do when you make rain paintings?** (Take turns to use the spray bottle. Share markers.)
- **In our Bible story today Jesus told a story about a rain-storm. When it rained, a house that was built on the sand fell down. The builder had not followed good building instructions. Jesus told this story so that we would remember to obey God's instructions that we read in the Bible.**
- **One good thing the Bible tells us to do is to be kind. What is a way you can be kind to the people in your family?** (Let someone have first choice.) Pray briefly, **Thank You, God, for the Bible. Please help us to obey Your instructions. In Jesus' name, amen.**

FOR OLDER CHILDREN

Tape four or more sheets of card stock together. Turn over the card stock and let pairs of children work together to draw a group picture or design for their rain paintings.

GOD'S WORD

"Do not merely listen to the word, and so deceive yourselves. Do what it says."
James 1:22

FOR YOUNGER CHILDREN:

"Obey God's Word."

GOD'S WORD & ME

The way to have wisdom and confidence
is to obey God's commands.



ART CENTER

FOR OLDER CHILDREN • MATTHEW 7:24-27

COLLECT

Bible, broom, sidewalk chalk, several cups of water.

PREPARE

Sweep pavement outdoors allowing approximately one square foot in which each child may draw. (Optional: If you have more than one broom, children sweep pavement before drawing.)

DO

1. (Optional: If children have not heard the Bible story, read Matthew 7:24-27 aloud.) Lead children in brainstorming different scenes of this parable. Each child chooses a scene to draw.
2. Each child dips a piece of chalk in water and draws a geometric shape in which to draw. Shapes should be at least 1 ft (30.5 cm) in size.
3. Dipping chalk into water frequently, children draw scenes. Encourage children to fill in the shapes as much as possible.

TALK ABOUT

- If Jesus were telling this parable today, what are some other things the two men might have been building instead of a house? (A shopping mall. A skyscraper.) What reasons can you think of for following instructions? How many reasons can you think of?
- Ask a child to read James 1:22 aloud. What are the two kinds of people who are described in this verse? (Someone who listens but doesn't obey. Someone who obeys.)
- Think about which kind of person you are most like. Pray, asking God's help in listening and obeying His instructions in the Bible.

FOR YOUNGER CHILDREN

Children draw houses with chalk.

GOD'S WORD

"Do not merely listen to the word, and so deceive yourselves. Do what it says."

James 1:22

FOR YOUNGER CHILDREN:

"Obey God's Word."

GOD'S WORD & ME

The way to have wisdom and confidence is to obey God's commands.



WORSHIP CENTER

MATTHEW 7:24-27

COLLECT

Bibles, *Parable Quest* CD-ROM and CD player, Lesson 3 Pattern Page (p. 84), song charts (pp. 248, 254), inflated balloon or ball, box or other container, scratch paper.

PREPARATION

Copy Pattern Page and cut apart to make at least two sets of verse cards. (Optional: Use cards from Game Center for Older Children.)

Team Game

Bat balloon or gently toss ball to children. (Optional: Children stand or sit in large circle.) Child who catches balloon or ball tells first word that comes to his or her mind when hearing the word "rain." Continue activity, each time calling out a different word such as "sand," "house," "rock," "wise," "fall," "build" and "foolish."

BIBLE VERSE GAME

Repeat James 1:22 aloud with children. Then place a box at the front of the room. Divide group into at least two teams of up to eight children each and place a set of verse cards for each team by the box. Children on each team take turns crumpling scratch paper into paper balls and tossing balls into the box. Each time a child gets a paper ball in the box, he or she collects a card for his or her team. When team has collected a complete set of verse cards, team members work together to put them in verse order.

SONG

You, or another leader, lead children in singing "All of the Time," adding motions and/or clapping if desired.

PRAYER

Psalm 119:133 was written as a prayer to God, asking His help in obeying His Word. Let's pray it together today. Lead children in prayer, by reading this verse, or asking a child to read it aloud.

SONG

You, or another leader, lead children in singing "Wise Up!" adding motions and/or clapping if desired.

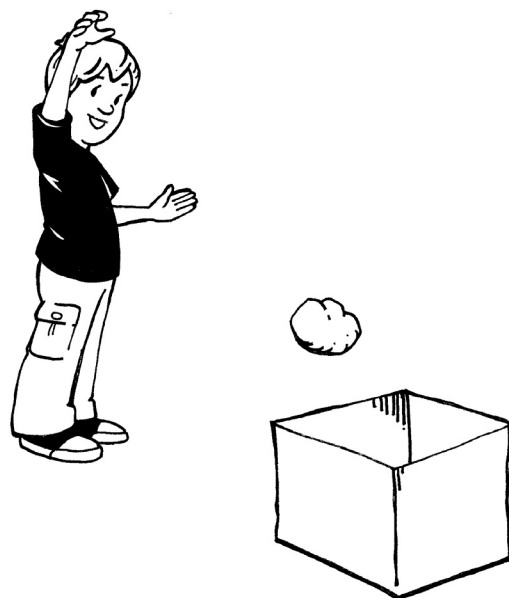
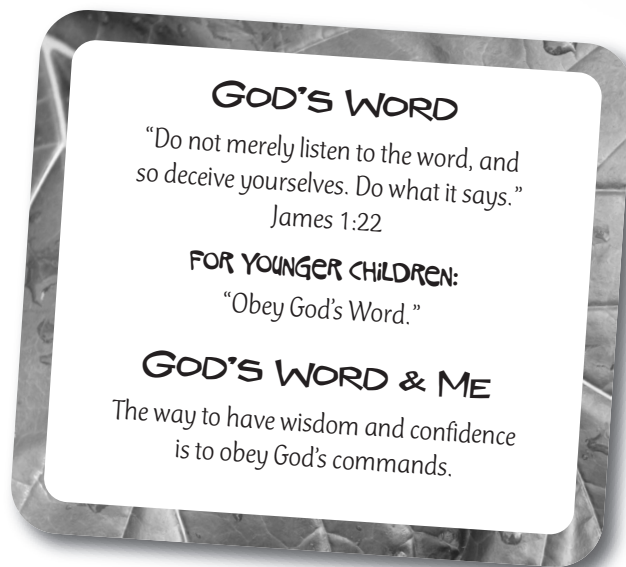

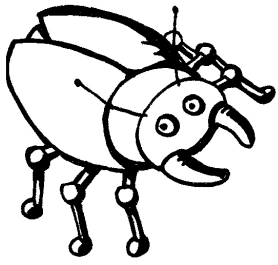

“Do

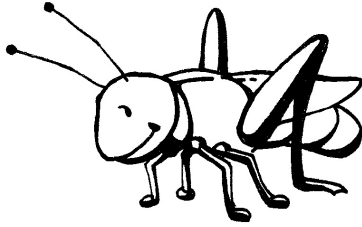

not

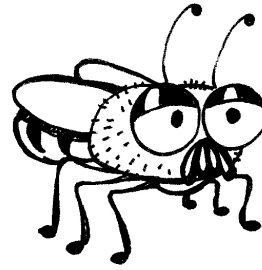

merely

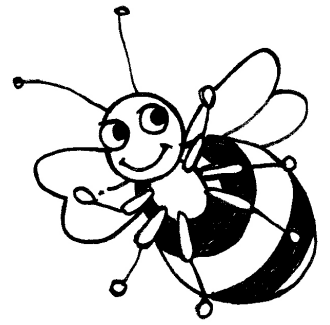

listen

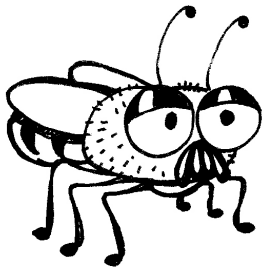

to

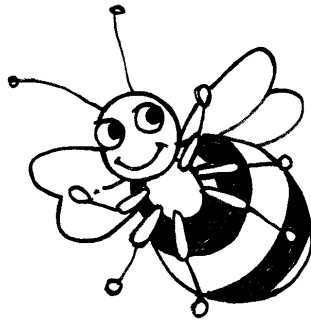

the

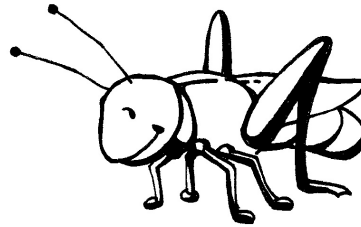

word,

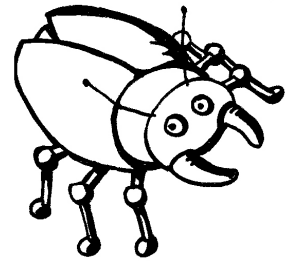

and

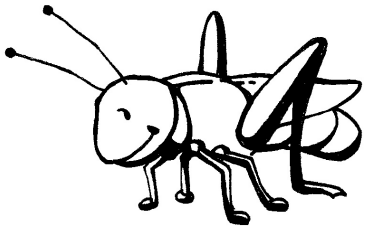

so

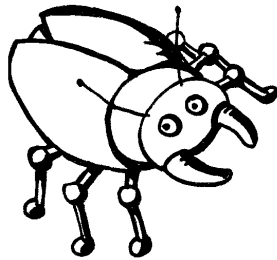

deceive

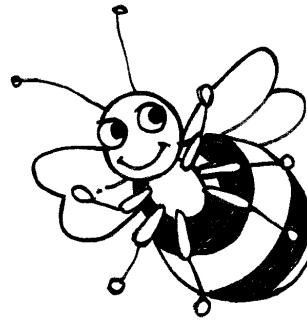

yourselves.

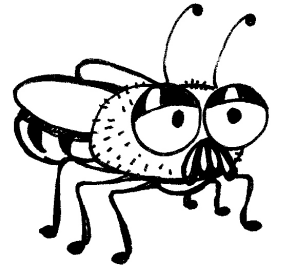

Do

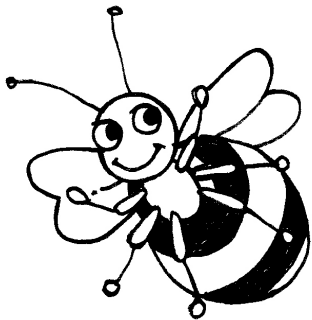

what

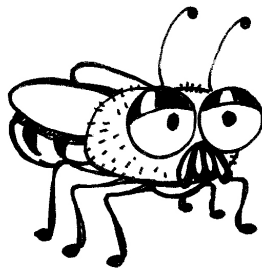

it

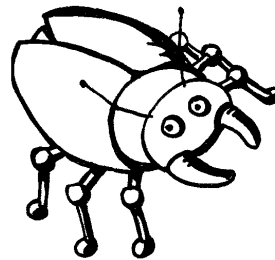

says.”

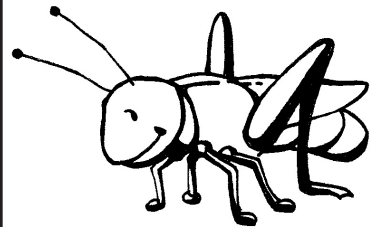

James 1:22

Jesus teaches about the wise and foolish men.

Matthew 7:24-27

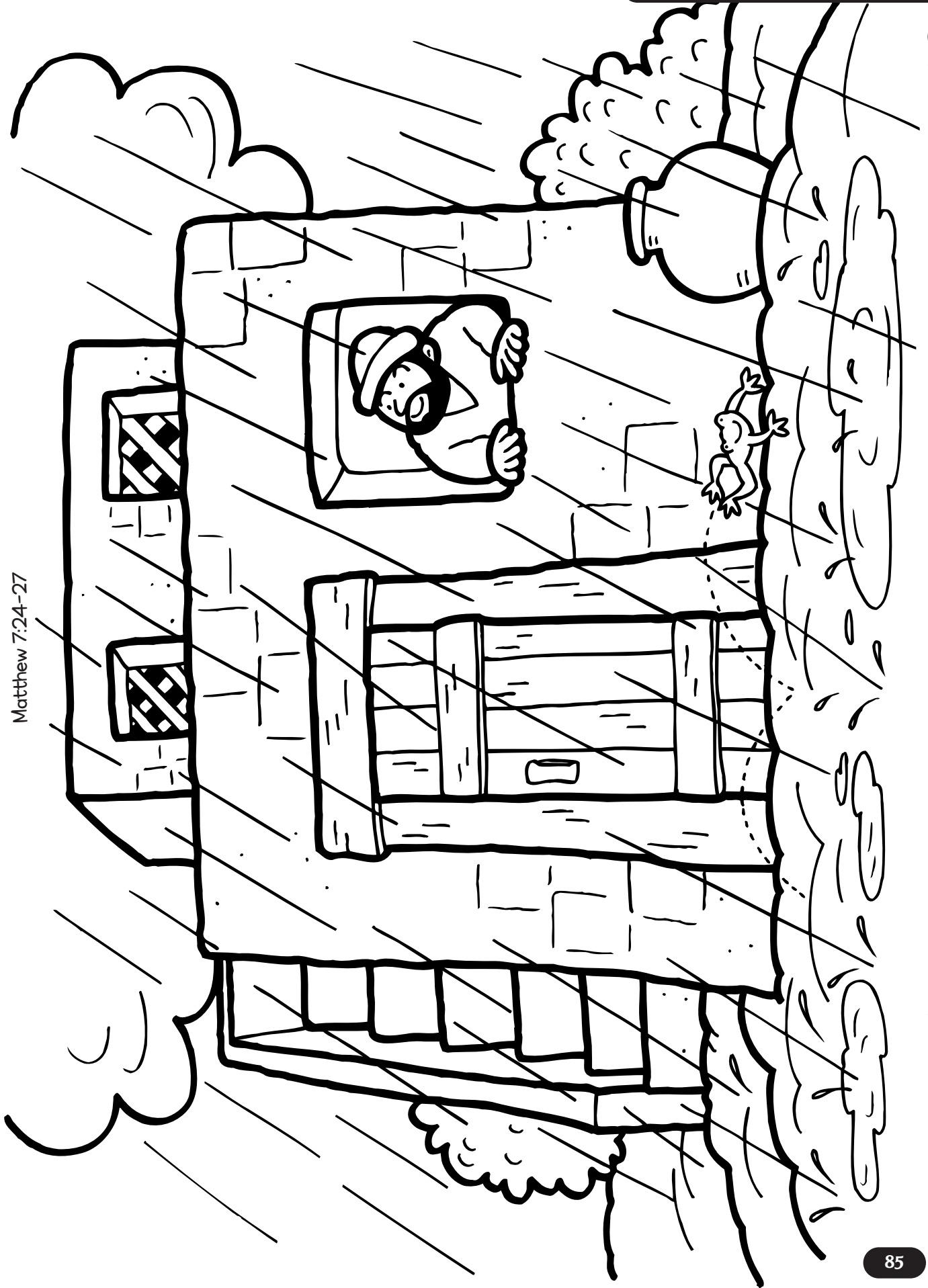

The wise man built a strong house. What can you do to be wise and obey God's Word, the Bible?

FROM FOOL TO WISE!

First, use the clues below to change “fool” to “wise.” Then, start at the dot to circle every other letter. Write the circled letters below to read what James has to say about being wise! (The dots show where words start.)

F	O	O	L

Someone who doesn't listen—

What sheep wear—

What trees become—

What isn't narrow—

Someone who listens and does God's commands!

What's a command you want to obey?

J̣ḌṂỌṚṆP̣ỌḶṬẠḄẸẈṚC̣ẸṆḶḌỴẸḶF̣ỊG̣ṢḤṬỊẸḤṆJ̣ṬḲỌA
 ṬḶḤṂẸṆẈỌỌḶṚḄḌṢ . . . ḌṂỌJ̣ẈG̣ḤṆẠQ̣ṬẈỊỌṬẠṢJ̣ẠṚỴP̣ṢC

“ _____ ”

SOWER

MATTHEW 13:1-23; MARK 4:1-20; LUKE 8:4-15



Teacher's Devotional

Do you raise petunias in pots? Tomatoes in tubs? Rows of everything from carrots to peppers? If you've ever planted seeds and then watched, worked and weeded to help them bear fruit, you can immediately visualize Jesus' Parable of the Sower. Jesus' parables always compare something familiar with something supernatural. In this case, the seed is actually God's Word. Planted in receptive soil, His Word grows to bear spiritual fruit! The story is mainly about soil conditions—the conditions of heart-soils, not literal dirt. It should make us ask, *What's the condition of my heart-soil?*

Without a serious "fruit check," we can do outward "Christian things" while having heart-soil that is hard, shallow or choked by the daily worries and crises—we fail to focus on the reality that the "growth" is not the same as producing fruit! To gauge the condition of your heart-soil, notice what spiritual fruit grows there: Is there greater love now for a person you used to avoid? Is there more patience and deeper joy in the middle of a situation you once complained about bitterly? Are your words more kind and thoughtful than they were last year? You see, only fruit proves that heart-soil is good.

Once we've checked our "FQ" (fruit quotient), it's time to invite the Master Gardener (God's Spirit) to help us uproot or remove every hindrance. Remember, open, receptive and deep heart-soil yields spiritual fruit when God's Word is sown there!



GOD'S WORD

"Live a life worthy of the Lord and . . . please him in every way: bearing fruit in every good work, growing in the knowledge of God."
Colossians 1:10

FOR YOUNGER CHILDREN:

"Please God by doing good things and getting to know who God is."

GOD'S WORD & ME

Growing as followers of God begins when we love and obey God's Word.

PLANNING PAGE

Choose which centers you will provide and the order in which children will participate in them (see pp. 14-18 for schedule tips and pp. 24-25 for guidelines in combining older and younger children). Also plan who will lead each center (for staffing tips see pp. 19-21). Use the reproducible planning sheet (p. 238) to record your plans.

BIBLE STORY CENTER

BIBLE STORY

Sower • Matthew 13:1-23; Mark 4:1-20; Luke 8:4-15

ADVENTURE BOX (YOUNGER CHILD)

Use props (four resealable plastic bags, each bag containing one of the following: hard-packed dirt, rocky soil, weedy soil and potting soil) to illustrate story action

ADVENTURE BOX (OLDER CHILD)

Use props (four pots, each pot containing one of the following: hard-packed dirt, rocky soil, weedy soil and potting soil) to illustrate story action

ART CENTER

YOUNGER CHILD OPTION

Make Bible story scenes-in-a-bag and talk about learning to do good things from God's Word

MATERIALS

Bible; plastic spoons; potting soil; some or all of the following items—3-inch (7.5-cm) pieces of small artificial or real plants, large artificial or real leaves, unpopped popcorn kernels for "seeds," small rocks, artificial blossoms; paper plates or trays; for each child—resealable plastic baggie

OLDER CHILD OPTION

Make an easel card and talk about what it means to grow in God's ways

MATERIALS

Bible, Lesson 4 Pattern Page (p. 98), card stock, scissors, markers (thin-tip if possible)

GAME CENTER

YOUNGER CHILD OPTION

Play a fun water game to show that listening to God's Word results in doing good things

MATERIALS

Bible, one or more bath towels, one or more large containers (tubs or plastic storage bins), water, a variety of small items, disposable cups

OLDER CHILD OPTION

Play a fun balloon game to review Colossians 1:10 and talk about ways to get to know God and His Word

MATERIALS

Bible, balloons, masking tape, large sheet of paper, markers

COLORING/PUZZLE CENTER

YOUNGER CHILD OPTION

Review the Bible story while completing coloring page

MATERIALS

Lesson 4 Coloring Page (p. 99) for each child, crayons

OLDER CHILD OPTION

Review ways of obeying Colossians 1:10 while completing puzzle page

MATERIALS

Lesson 4 Puzzle Page (p. 100) for each child, pencils

WORSHIP CENTER

FOR THE YOUNGER AND OLDER CHILD

Participate in large-group activities to review Bible verse and to worship God together

MATERIALS

Bibles, *Parable Quest* CD-ROM and CD player, song charts (pp. 246, 253), two or more unpeeled oranges

BONUS THEME IDEAS

Bonus Theme Ideas can be used at any time during this session: as an additional activity center, to extend the session for a longer time, or for added theme excitement.

JUNGLE SNACK

Ahead of time (or let children help you if time and facilities permit), mix 1 cup of orange juice and 1 cup of pineapple juice. Add 1 can of lemon-lime soda and 1 pint of lime sherbet right before serving. Serve a cup of punch and fish crackers or any jungle animal-shaped crackers.

Post a note alerting parents to the use of food. Also, check registration forms for possible food allergies.



RAINFOREST SCENTS

Prepare or purchase white play dough. (See recipe on *Parable Quest* CD-ROM.) Give each child a fist-sized ball of dough. Offer small amounts of these rainforest scents for children to add to their play dough: spices (cinnamon, cloves, ginger, nutmeg, paprika), vanilla and instant coffee. Children will enjoy working the scented item into the dough and then trading with each other to play with the dough and take a sniff! (If time permits, child wears bandanna, sniffs dough and guesses the scent.) Give each child a plastic baggie in which to take home their rainforest balls.

DRESS-UP DAY

Plan a Dress-Up Day at which you invite children to come wearing shirts or hats or carrying special props to dress up as explorers in a rainforest jungle. For example, a child may wear a vest and a jungle hat or pith helmet. Encourage children to invent their own explorer names. Take pictures of children to display. (Optional: You may also choose to have some dress-up clothes on hand for children to wear.)

BIBLE STORY CENTER

FOR YOUNGER CHILDREN •
MATTHEW 13:1-23; MARK 4:1-20; LUKE 8:4-15

INTRODUCTION

Welcome your rainforest explorers by saying **In the rainforest, plants and trees can grow very, very tall! Let's pretend we're growing in the rainforest.** Have children crouch down on the floor representing small seeds. Then lead them to very slowly stand up, pretending to "grow," until they are standing straight up with arms held high. Repeat several times. Then show Adventure Box. **What do you think is in our Adventure Box today? Let's find out!** Untie box. Remove items from box and use them to demonstrate story action as you tell the story and/or lead children in suggested motions.



ADVENTURE BOX

In a cardboard or wooden box labeled "Adventure," place a Bible and four re-sealable plastic bags, each bag containing one of the following: hard-packed dirt, rocky soil, weedy soil and potting soil. Tie rope or brown yarn around the box or crate.

TELL THE STORY

When Jesus lived on Earth, He helped people. He also told stories no one had heard before. One day Jesus told about a farmer.

In Bible times, farmers didn't have tractors or other equipment to help them plant seeds or grow crops. A farmer carried the seeds in a large bag he slung over his shoulder. He would reach into the bag, grab a handful of seeds and scatter the seeds as far as he could. (*Pantomime reaching into bag, scattering seed.*)

Jesus said, "A farmer went out to plant his crop. He began scattering seeds all over the ground. (*Children join you in pretending to scatter seeds.*) Some seeds landed on hard dirt. (*Pass around bag of hard soil.*) Those seeds didn't even get covered up. Hungry birds came and gobbled them up! (*Pretend to be birds, eating seeds.*)

"Other seeds landed on rocky ground. (*Pass around bag of rocky soil.*) But there wasn't enough water, and the plants soon died."

Jesus continued, "As the farmer scattered his seeds, some fell where thorny weeds were already growing. (*Pantomime reaching into bag and scattering seed; pass around bag of weedy soil.*) The weeds grew faster and stronger than the plants. The plants couldn't grow! These plants died, too!

"But SOME seeds landed in good soil. (*Pantomime reaching into bag and scattering seed; pass around bag of good soil.*) Those seeds that fell into the GOOD dirt grew into strong plants. The plants grew a HUGE crop. Those few seeds produced HUNDREDS and HUNDREDS more seeds than the farmer had planted!"

Jesus said, "The seeds are like God's Word! The different kinds of dirt are like people when they hear God's Word. (*Show bag of hard soil.*) People who hear God's Word but never believe it are like the hard dirt where birds ate the seeds! Some people hear God's Word and gladly believe it. They are like seeds that fell into shallow, rocky dirt. (*Show bag of rocky soil.*) But when hard things happen to them, they stop doing what it says.

(*Show bag of weedy soil.*) "People like the dirt with the thorny weeds are people who believe God's Word. They begin to grow, but then their worries keep them from growing. Soon they forget about God's Word." (*Show bag of good soil.*) "But," Jesus smiled, "people who hear and obey God's Word are like the good soil. They love and obey God's Word. Soon, others want to hear about God from them!"

GOD'S WORD & ME

Jesus wants us to be like the good soil. He wants us to hear God's Word and then do what it says! The Bible says, "Please God by doing good things and getting to know who God is." Knowing what God's Word, the Bible, says helps us know who God is! It helps us to learn and grow in the very best way! Pray, Dear Jesus, please help us to listen to God's Word and learn about God so we grow in knowing Him. We love You. Amen.



BIBLE STORY CENTER

FOR OLDER CHILDREN •
MATTHEW 13:1-23; MARK 4:1-20; LUKE 8:4-15

INTRODUCTION

Lead children in a game like Pictionary. First player draws picture of any fruit or vegetable on a large sheet of paper or white board. Other children try to guess the item. Continue game with other volunteers drawing pictures as time permits. Be ready to suggest fruits and vegetables such as apples, oranges, cherries, strawberries, corn, string beans, potatoes, etc. **Today we're going to talk about plants . We'll hear about some seeds that were planted—and what happened!**

What do you think is in our Adventure Box today? Let's find out!

Untie box. Remove items from box and use them to demonstrate story action as you tell the story.

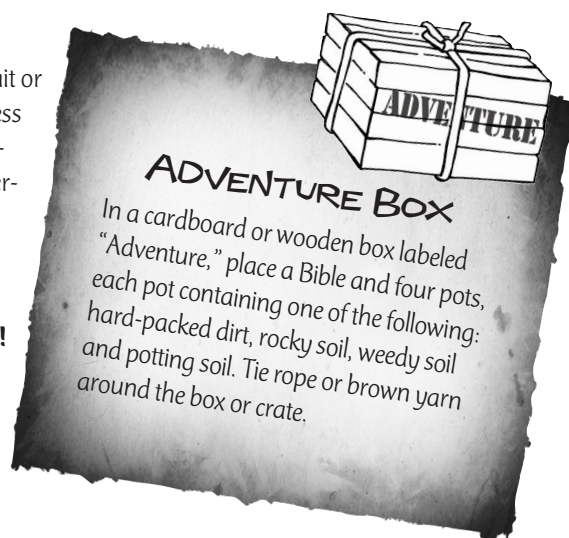

TELL THE STORY

When Jesus lived on Earth, He did things no one else could do. He said things no one else had ever heard before. So whenever people heard that Jesus was coming, they all wanted to see Him! One day, Jesus stepped into a boat to teach. That way, everyone would be able to see and hear Him. The people settled down on the shore to hear Jesus' story.

Jesus began with a story about a farmer. In Bible times, farmers didn't have tractors or other equipment to help them plant seeds or grow crops. To plant seeds, a farmer carried the seeds in a large bag he slung over his shoulder. He would reach into the bag, grab a handful of seeds and scatter the seeds as far as he could. (*Pantomime reaching into bag and scattering seed.*)

Jesus' said, "A farmer went out to his field to plant seeds. As he walked, he took handfuls of seeds from his seed pouch and scattered them across the ground.

"Now some of the seeds fell on a pathway where the dirt had been walked over many times. It was hard and smooth. (*Pass around pot of hard soil.*) It was SO hard, no seed could ever put down roots there! So the seeds just bounced off the hard ground and lay there—until birds swooped down and snatched up the seeds!"

The people listening to Jesus' story nodded. They had all planted gardens and sown seeds themselves or seen it done. They knew that a seed on hard ground would NEVER become a plant that produced fruit! Those seeds were just food for hungry birds!

(*Pantomime reaching into bag and scattering seed.*) Some of the seeds landed in soil that was shallow. A layer of rock was beneath this soil. (*Pass around pot of rocky soil.*) The seeds sprang up quickly because the soil was warm and shallow. But when the plants grew a little more, their roots hit the rock and could go no farther. The shallow soil couldn't hold much water, so the little plants dried up.

Jesus continued, "Some of the seeds fell on soil that was already full of weeds. (*Pantomime reaching into bag and scattering seed, and then pass around pot of weedy soil.*) The seeds began to grow, but the weeds were already growing! They had a head start. So as the thorny weeds grew bigger and bigger, they took all the water and light the young plants needed. Soon, the weeds choked all the young plants and kept them from ever growing bigger."

Some people began to wonder, *Will this farmer have any crop at all?* But Jesus' story wasn't finished. (*Pantomime reaching into bag and scattering seed, and then pass around pot of potting soil.*)

He said, "The rest of the seeds fell on soft, rich soil. They were able to sprout, take root and grow into big plants. They made an enormous crop! Some plants had produced 30 times what the farmer had planted, some 60 times and some even a HUNDRED times more than what he had planted."

Jesus ended His story by saying, "He who has ears to hear, let him hear." The disciples looked at each other, puzzled. *What did the story mean?*

So the disciples asked Jesus and He told them, “This is what the parable means. A person who hears the Word of God is like one of the different types of soil.” It’s funny to think that Jesus said people are like soil, or dirt! But Jesus explained what He meant.

“People who hear the Word of God but never believe it are like the hard dirt path where the seeds were snatched up and eaten by birds,” Jesus said. *(Show pot of hard dirt.)* The disciples knew that some people had heard Jesus teach but never really paid attention to the truth of God’s Word and let it change their lives.

(Show pot of rocky dirt.) Then Jesus said, “Other people are like the shallow, rocky soil. They gladly believe God’s Word at first! But when trouble comes, when it becomes too hard to do what God wants, they forget all about God and His Word. The truth they heard dries right up.

“What about the ground that was full of thorny weeds?” one disciple may have asked. “What people are like that?” *(Show pot of weedy dirt.)* Jesus told them that these people become very, very busy with anything and everything besides God. They think about making more money or worry about things they don’t have. They are very busy paying attention to lots of things besides God’s Word. So the truth they heard is choked by all that busyness. Soon they struggle to even think about God. Their lives never grow up strong enough to really produce good fruit like love or joy.

(Show pot of potting soil.) The disciples probably could guess what Jesus would say about the good soil! “The GOOD soil is like people who hear and believe the Word of God,” Jesus said. These people grow when they think about, remember, and do what God’s Word says. Their lives show what they’ve learned about God. And more and more people learn about God’s truth because they see the good things that grow from these people’s lives.”

GOD’S WORD & ME

Jesus wants all of us to become like the good soil. We need to do more than just hear God’s Word. When we hear and then *believe* it, we grow by thinking about, remembering, and *doing* what it says. Then comes the fruit—our lives *showing* what we’ve learned! That is what makes the difference, every day! All of that starts when we realize how valuable God’s Word is.



- **What are some things we discover in the Bible that can make a difference in our lives every day?** (Commands of good things to do. Stories about how Jesus treated people. Salvation.)
- Invite a child to read Colossians 1:10 aloud. **What do you think this verse means? What are some ways a kid your age could live a life worthy of Jesus?** (Be patient with others. Tell the truth. Forgive others.)
- **What are some ways you would tell a kid your age to grow in the knowledge of God?** (Read God’s Word. Think about it. Pray.) **What do you think it means to bear fruit in every good work?** (Do and say things that show we are paying attention to God’s Word—act kindly, show love, live in peace, etc.) Pray with children, asking God to help them understand what kind of “soil” their hearts are like and to help them to love God’s Word and become good soil where it can produce fruit!

GAME CENTER

FOR YOUNGER CHILDREN • MATTHEW 13:1-23; MARK 4:1-20; LUKE 8:4-15

COLLECT

Bible; one or more bath towels; one or more large containers (tubs or plastic storage bins); water; a variety of small items—coins, toy animals, fake jewels, toy people, etc.; disposable cups.

PREPARE

Fill containers bins halfway with water. Place them on bath towels. (Optional: Play this game outdoors with children.)

DO

1. Let children help you place small items into the water. Children form two teams and line up across the room from the containers. Give first child in each line a cup.
2. At your signal, first child runs to containers, and uses cup to scoop out an item. Child places item on the towel and runs back to his or her team and hands the cup to the next child in line. If more than one item is scooped out of the water, child chooses one to set on towel and returns the others to the water.
3. Continue until each child has had a turn. If time permits, repeat game, replacing items in water and forming new teams.

TALK ABOUT

- **It's fun to play this water game together. I see you taking turns and cheering for your friends. You are doing just what the Bible tells us to do! The Bible tells us, "Please God by doing good things and getting to know who God is."**
- **What are some other good things we can do with our friends here at church?** (Let a friend choose what to play. Take turns on the slide on the playground.)
- **When we do good things, it shows that we are learning to love and obey God's Word as we grow up.** Invite children to tell how old they are and something they have learned to do now that they couldn't do when they were babies.
- **Pray briefly, Dear God, thank You for our friends at church. Thank You that they are growing and growing. Help each one to keep doing good things. In Jesus' name, amen.**

FOR OLDER CHILDREN

Children close their eyes or put on bandannas and see how fast they can find and remove items from water using only their hands.

GOD'S WORD

"Live a life worthy of the Lord and . . . please him in every way: bearing fruit in every good work, growing in the knowledge of God."

Colossians 1:10

FOR YOUNGER CHILDREN:

"Please God by doing good things and getting to know who God is."

GOD'S WORD & ME

Growing as followers of God begins when we love and obey God's Word.

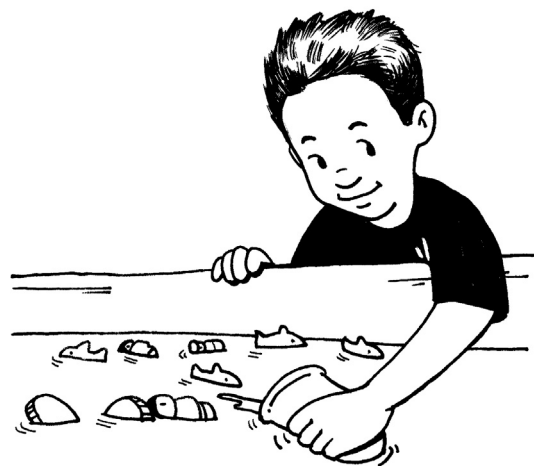

GAME CENTER

FOR OLDER CHILDREN • MATTHEW 13:1-23; MARK 4:1-20; LUKE 8:4-15

COLLECT

Bible, balloons, masking tape, large sheet of paper, markers.

PREPARE

Blow up and tie balloons (one for each pair of children). Use masking tape to make a long line on the floor in an open area. Print Colossians 1:10 on large sheet of paper.

DO

1. Divide group into pairs. Pairs stand on opposite sides of masking-tape line. Give one child in each pair an inflated balloon.
2. Pairs attempt to tap the balloon back and forth across the line to each other, repeating the words of the Bible verse in order. (Optional: Children stand in a circle and attempt to tap the balloon around the circle, repeating the words of the verse in order.)

TALK ABOUT

- Read Colossians 1:10 aloud. **What do you think is the most important word in this verse? Why? How does the word you chose remind you of the main message of the verse?**
- **It's fun to think about the cool stuff you get to do as you grow older. Colossians talks about growing, too. But this verse talks about all the amazing and wonderful things you can do to love God and follow Him as you grow to know Him. What can a kid your age do to get to know God better?** (Read and think about verses in the Bible. Talk to God about things that happen every day.)
- **What are some things you've seen people do that show that they love God and His Word and want to obey His Word and please Him?** (Take time to play with a younger kid. Explain the rules of a playground game to a new kid.)
- **Think about a way you want to obey God's Word and please Him.** Lead children in prayer, asking God's help in following Him.

FOR YOUNGER CHILDREN

Lead children in batting the balloons in unison and in saying the words of the verse all together. Use the verse paraphrase written for younger children.

GOD'S WORD

"Live a life worthy of the Lord and . . . please him in every way: bearing fruit in every good work, growing in the knowledge of God."
Colossians 1:10

FOR YOUNGER CHILDREN:

"Please God by doing good things and getting to know who God is."

GOD'S WORD & ME

Growing as followers of God begins when we love and obey God's Word.

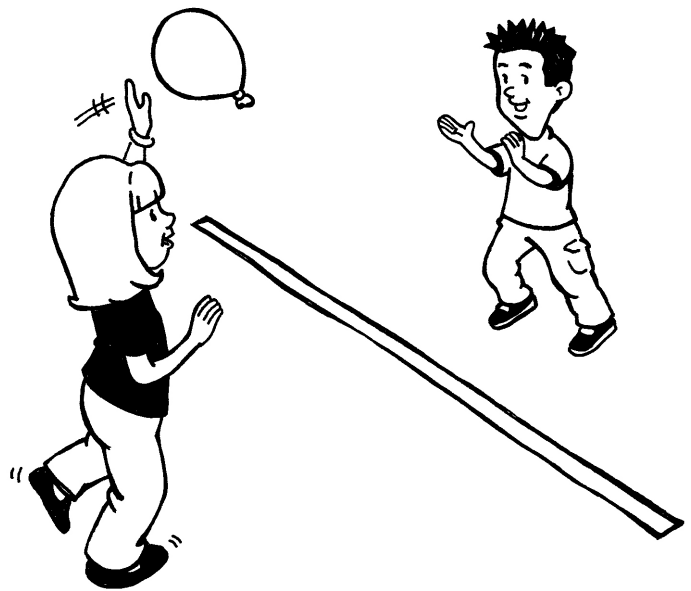

ART CENTER

FOR YOUNGER CHILDREN • MATTHEW 13:1-23; MARK 4:1-20; LUKE 8:4-15

COLLECT

Bible; plastic spoons; potting soil; some or all of the following items—3-inch (7.5-cm) pieces of small artificial or real plants, large artificial or real leaves, unpopped popcorn kernels for “seeds,” small rocks, artificial blossoms; paper plates or trays; for each child—resealable plastic baggie.

PREPARE

Set out soil, plants, leaves, kernels and blossoms on separate plates or trays.

DO

1. Give each child a plastic baggie.
2. Child places several spoonfuls of soil into baggie, and then adds other items representing the different parts of the parable of the sower Bible story.
3. Invite children to tell about the Bible story as they gently shake their scenes-in-a-bag and look at the items.

TALK ABOUT

• Jesus told a story about a farmer who planted seeds. Some of the seeds grew into big plants. You are growing, too. You are learning how to do good things. What good things are we doing as we make our scenes-in-a-bag?

(Taking turns to put items in bags. Helping when someone spills.)

• Jesus told the story about the seeds that grew to teach us to love and obey God’s Word. One thing God’s Word teaches us to do is to tell the truth. When are some times that kids your age can tell the truth? (When mom or dad ask if we’ve cleaned up our toys. When a big sister or brother ask us if we’ve taken something from their room.)

• The Bible says, “Please God by doing good things and getting to know who God is.” Let’s ask God to help us do the good things we learn about in the Bible. Pray briefly with children.

FOR OLDER CHILDREN

Give each child four baggies. Children place items representing the four soils in separate baggies. Staple baggies together in story order.

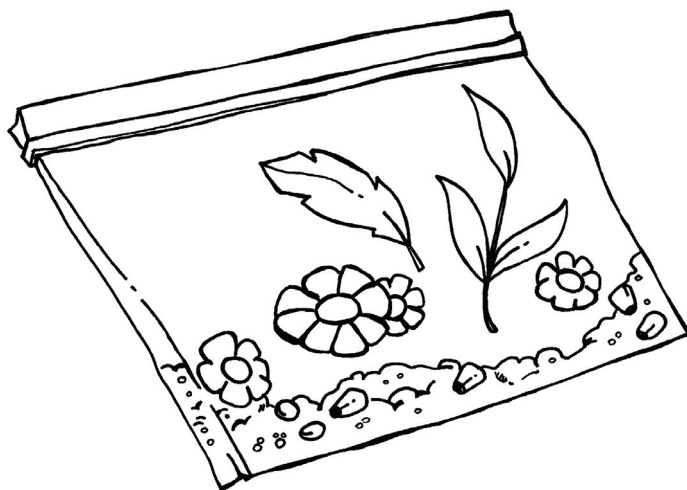
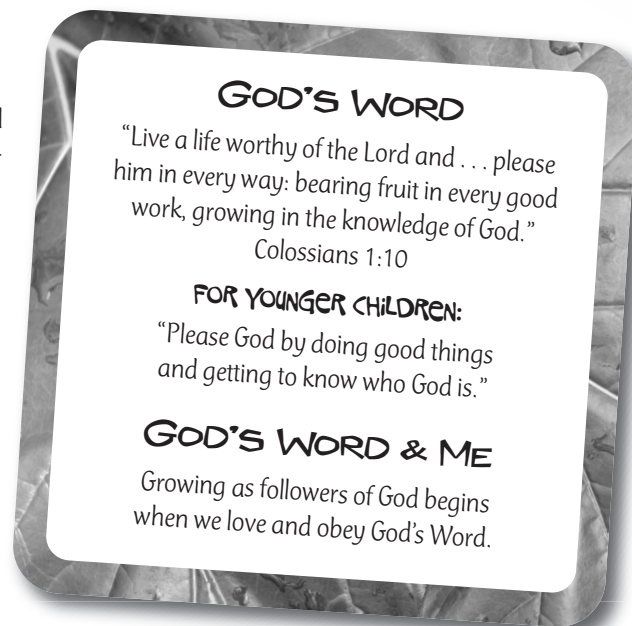

ART CENTER

FOR OLDER CHILDREN • MATTHEW 13:1-23; MARK 4:1-20; LUKE 8:4-15

COLLECT

Bible, Lesson 4 Pattern Page (p. 98), card stock, scissors, markers (thin-tip if possible).

PREPARE

Make a copy on card stock of Lesson 4 Pattern Page for each child. Make a sample easel and display card following directions below.

DO

1. Give each child a pattern page. Child cuts apart page as directed and colors designs.
2. Child folds easel in half so that colored portion is on the outside, and sets display card on the easel. If time permits, children may create additional display cards.

TALK ABOUT

- **What do you think it means to tell someone "Grow in God's Ways"?** (Follow God. Love and obey God. Learn more and more about how to live as a Christian.)
- **What's a way kids can show that they love God's Word and want to please God by obeying it?** (Read the Bible regularly. Think about what Bible verses mean. Ask God's help in obeying.)
- Read Colossians 1:10 aloud. **Who is someone you know who obeys this verse? What does he or she do?**
- **What is a way that has been easy for you to obey God's Word and please Him? Think about a way in which you need help to please God.** Lead children in a brief prayer, asking God's help in following Him.

FOR YOUNGER CHILDREN

Cut apart pages and fold easels ahead of time for children.

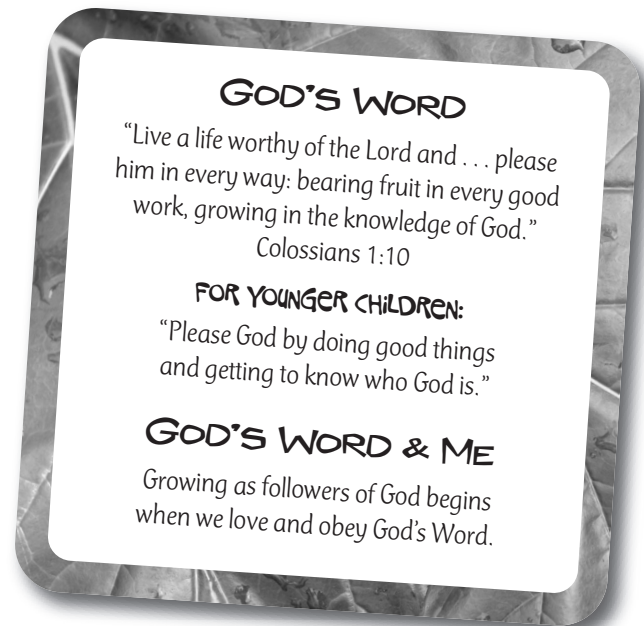

WORSHIP CENTER

MATTHEW 13:1-23; MARK 4:1-20; LUKE 8:4-15

COLLECT

Bibles, *Parable Quest* CD-ROM and CD player, song charts (pp. 246, 253), two or more unpeeled oranges.

TEAM GAME

Divide group into two or more teams. Select up to eight players from each team to participate in a relay. Players from each team remove shoes and socks and sit in a line on the floor. Give the first player on each team an orange. At your signal, players use only their feet to pass the orange down the line. Last person in the line unpeels the orange (they can use their hands!) and divides it into sections. Team members eat the orange sections. Children cheer for their team members.

BIBLE VERSE GAME

Repeat Colossians 1:10 aloud with children. Demonstrate sign language for the verse and have children practice signs with you. Then repeat verse several times with signs. (Optional: Divide group in half. One half says verse while the other half does the signs. Then reverse roles.)

SONG

You, or another leader, lead children in singing "Salt," adding motions and/or clapping if desired.

PRAYER

What are some actions or verbs that tell what we can do to live as followers of God? (Be honest. Be fair. Be patient. Take turns. Don't tease little kids.) Volunteers pray, completing the sentence "God, please help us . . ." End prayer by thanking God for the Bible that helps us know how to follow Him.

SONG

You, or another leader, lead children in singing "Following Jesus," adding motions and/or clapping if desired.

GOD'S WORD

"Live a life worthy of the Lord and . . . please him in every way: bearing fruit in every good work, growing in the knowledge of God."
Colossians 1:10

FOR YOUNGER CHILDREN:

"Please God by doing good things and getting to know who God is."

GOD'S WORD & ME

Growing as followers of God begins when we love and obey God's Word.

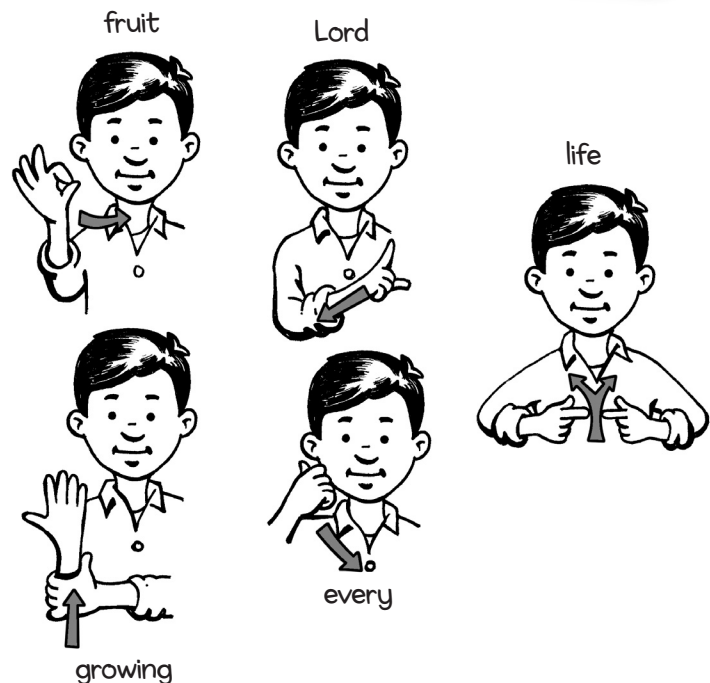

Cut off.

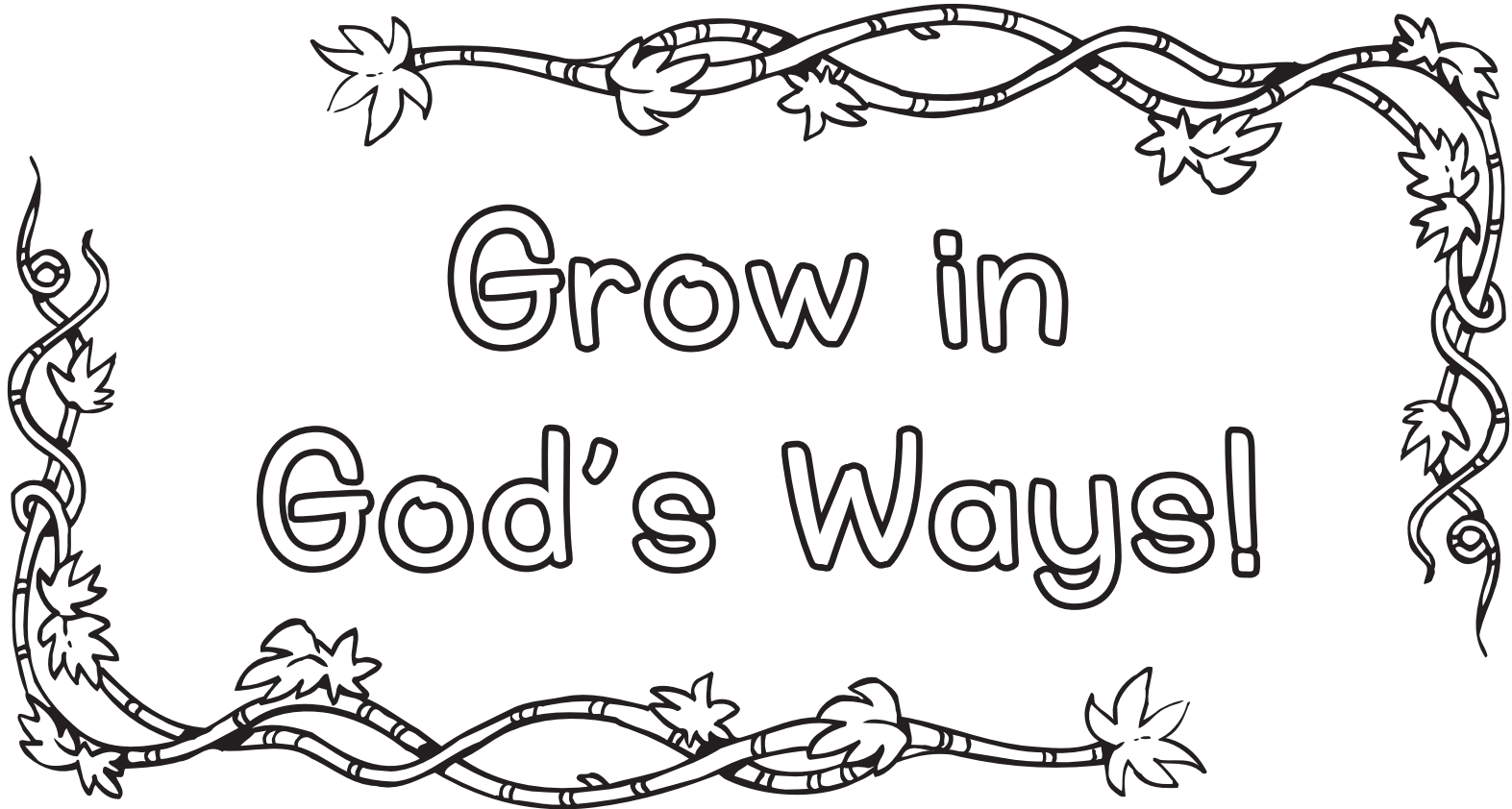

Grow in God's Ways!

Cut off.

Cut off.

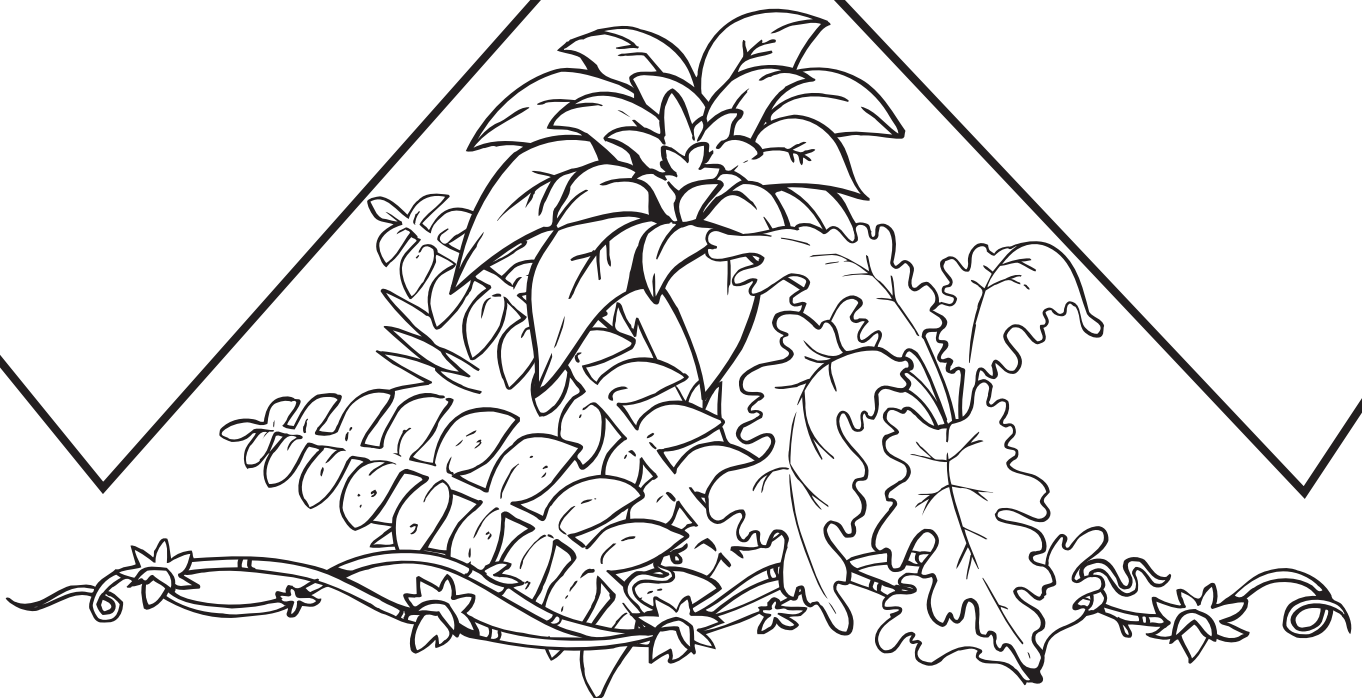

Cut off.

Jesus tells the parable of the sower.
Mark 4:1-20



What is growing on this page?
As you grow up, God's Word, the
Bible, helps you learn how to obey God.

FRUITFUL!



To find out how to be a growing, fruitful follower, color in every

- animal name**
- plant name**
- color**

and then write the remaining words in order below!



LOST SHEEP

MATTHEW 18:12-14; LUKE 15:3-7



**DEPEND ON
GOD'S LOVE**

TEACHER'S DEVOTIONAL

Ever been made uncomfortable by seeing who is walking through the doors of your church? It's pretty common to our human nature! Jesus often skirmished with Pharisees and teachers of God's law who were equally uncomfortable seeing the "sinners" of various sorts whom Jesus welcomed and with whom He shared meals. Certain that they were part of an elite few who daily fulfilled the requirements of the Law, they judged Jesus to be some kind of inferior rabbi because He let such undesirables "through the doors" at all! These devout (and self-righteous) men didn't understand that even THEY were sinners!

So Jesus told them a story of a shepherd who leaves ninety-nine of his (nice, clean, safe) sheep to find the one sheep that was lost. This shepherd isn't content to delight in the fact that he has most of his sheep! He is focused on bringing home the one that is lost. Jesus' story clearly made the point that God delights to bring home ANY "lost sheep." Each one matters to Him—regardless of background, occupation or "degree" of sinfulness!

Like the Pharisees, we can be fooled into thinking that we're a little better than some "other." We can even judge that there are folks not worth saving. But Jesus' story makes the extent of God's love a vivid reality: We're all *equally*, hopelessly lost. God sought us until He brought us to Himself. Thank Him for all He has done to save you—and then invite Him to bring an "undesirable" into your circle whom *you* could welcome, eat with—and love to Him!

GOD'S WORD

"I pray that you, being rooted and established in love, may have power, together with all the saints, to grasp how wide and long and high and deep is the love of Christ."

Ephesians 3:17-18

FOR YOUNGER CHILDREN:

"Discover how wide and deep is the love of Christ."

GOD'S WORD & ME

Nothing we do can change God's generous love for us.

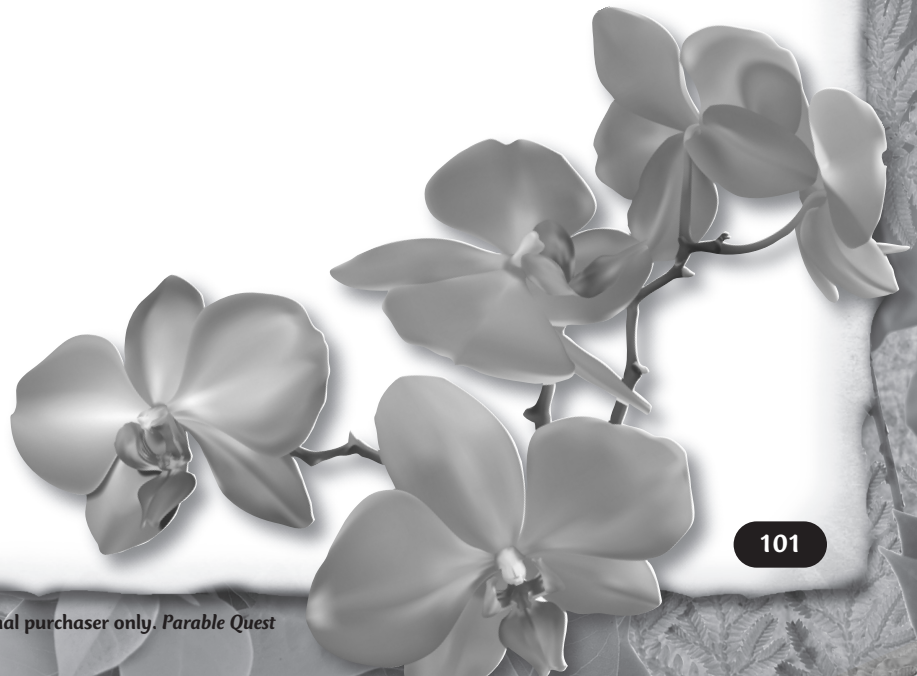

PLANNING PAGE

Choose which centers you will provide and the order in which children will participate in them (see pp. 14-18 for schedule tips and pp. 24-25 for guidelines in combining older and younger children). Also plan who will lead each center (for staffing tips see pp. 19-21). Use the reproducible planning sheet (p. 238) to record your plans.

BIBLE STORY CENTER

BIBLE STORY

Lost Sheep • Matthew 18:12-14; Luke 15:3-7

ADVENTURE BOX (YOUNGER CHILD)

Use paper plate sheep masks to demonstrate story action

ADVENTURE BOX (OLDER CHILD)

Use props (bag of 100 cotton balls, large plastic bowl and stuffed toy sheep) to demonstrate story action

ART CENTER

YOUNGER CHILD OPTION

Make people from geometric shapes and talk about ways God shows His love

MATERIALS

Bible, construction paper in a variety of colors, scissors, glue sticks, 2-ft (0.6-m) length of butcher paper for each child

OLDER CHILD OPTION

Draw pictures for a mural in which flaps can be lifted to discover ways God shows His love

MATERIALS

Bible, length of butcher paper, pencil, scissors, white paper, markers, construction paper, tape

GAME CENTER

YOUNGER CHILD OPTION

Build sheep pen and gather cotton ball sheep to review Bible story and talk about God's great love

MATERIALS

Bible, blocks, cotton balls (at least five for each child)

OLDER CHILD OPTION

Play a game to gather Bible verse cards and talk about times kids need to remember God's great love

MATERIALS

Bible, Lesson 5 Pattern Page (p. 112), paper in at least two colors, scissors

COLORING/PUZZLE CENTER

YOUNGER CHILD OPTION

Review the Bible story while completing coloring page

MATERIALS

Lesson 5 Coloring Page (p. 113) for each child, crayons

OLDER CHILD OPTION

Review Ephesians 3:17-18 while completing puzzle page

MATERIALS

Lesson 5 Puzzle Page (p. 114) for each child, pencils

WORSHIP CENTER

FOR THE YOUNGER AND OLDER CHILD

Participate in large-group activities to review Bible verse and to worship God together

MATERIALS

Bibles, *Parable Quest* CD-ROM and CD player, song charts (pp. 247, 250), whistle

BONUS THEME IDEAS

Bonus Theme Ideas can be used at any time during this session: as an additional activity center, to extend the session for a longer time, or for added theme excitement.

SANDWICH PUZZLES

Provide a slice of white and wheat bread for each child, plus a variety of cookie cutters. (Optional: Use rainforest animal shapes, if possible.) Each child chooses a cookie cutter and cuts a shape from each slice of bread. Then child places white shape into cut-out wheat bread and places wheat shape into cut-out white bread. Have fun eating the sandwich puzzles! (Optional: Make puzzles from cheese and sandwich meat slices, too!)

Post a note alerting parents to the use of food. Also, check registration forms for possible food allergies.



FACEPAINT FUN!

Provide face paint in a variety of colors (green, red, yellow, brown) by adding various colors of food coloring to 3 tablespoons shortening mixed with 2 tablespoons cornstarch. (Optional: Purchase face paint crayons.) Set out face paints along with cotton swabs or paintbrushes and invite children to paint faces to resemble rainforest creatures: spots like a jaguar, wings like a butterfly or feathers like a parrot. Tell children (and parents) that face paint can be removed with soap and warm water.

FAMILY FUN NIGHT

Send invitations to families (see p. 233 for a sample that can be modified) to a rainforest-themed movie night. (Include a brief description of the movie.) Serve rainforest snacks and show a family film. Ask families to bring sleeping bags, blankets, or beach chairs on which to sit and a favorite snack to share with others. (Optional: Provide one or more of the rainforest snacks suggested in this book.) Provide beverages. You may also choose to give each child a party favor bag to take home. Fill bags with inexpensive favors—nature stickers, gum, wrapped bite-size candy, etc., as well as information about your church's children's or family programs.

BIBLE STORY CENTER

FOR YOUNGER CHILDREN •
MATTHEW 18:12-14; LUKE 15:3-7

INTRODUCTION

Welcome your rainforest explorers by saying, **Let's pretend to be monkeys in the rainforest. Let's try climbing up a tree.** Lead children in climbing motions. **Now let's swing from vine to vine!** Lead children to swing arms. **How do you think monkeys say "hello" to each other?** Invite children to give ideas. **Let's say "hello" like monkeys might do!**

What do you think is in our Adventure Box today? Let's find out!

Invite a volunteer to help you untie box. Remove items from box. Give each child a paper plate so that they can pretend to be sheep and act out the story as you tell it.



ADVENTURE BOX

In a cardboard or wooden box labeled "Adventure," place a Bible, paper plates (one for each child) on which you have drawn sheep faces. Tie rope or brown yarn around the box or crate.

TELL THE STORY

One day Jesus told a story about a shepherd. A shepherd is a person who takes care of sheep. This shepherd had 100 sheep. He loved his sheep. He took good care of his sheep. And he knew the name of every one of his sheep! *(Children hold paper plate masks to their faces and crouch down, pretending to be sheep. Pretend to be the shepherd and walk around and touch each "sheep" on the head and say child's name.)*

The shepherd would lead the sheep to yummy green grass and cool streams of water every day. *(Walk in place; invite "sheep" to join you in story actions.)* At the end of each day, he would take the sheep to a place called a sheepfold. *(Make circle with arms.)* The sheep would be safe there for the night. The shepherd counted each sheep as it walked into the sheepfold. *(Lead "sheep" into area of room to represent sheepfold. Have one "sheep" stay behind a table or chair to represent the lost sheep.)*

One day, the shepherd was counting his sheep. He counted 1 . . . 2 . . . 3 . . . all the way up to 98 . . . 99 . . . but, oh no! ONE sheep was missing! *(Count children.)* Where could that little sheep be? *(Look left and right.)*

Right away, the shepherd left the other 99 sheep. He went looking for the one lost sheep. He looked high, he looked low, he looked under trees and he looked around rocks. *(Shade eyes and look around.)* Where could his little sheep be? He called the sheep's name. Then he stood very, very still and listened and LISTENED. *(Call, "Sheepy!" then sit still, turning head and cupping hands behind ears to listen.)* Finally, he heard a little noise. He heard the distant "Baa, baa!" of his lost sheep.

The shepherd found his little sheep. *(Hug the lost "sheep" and lead it to the sheepfold.)* The shepherd reached down and lifted the sheep onto his shoulders. The shepherd was so happy! He carried the sheep all the way home. He told all his friends, "Be glad with me! I found my lost sheep!"

When Jesus lived on Earth, He told this story to help us know how much God loves us! God loves us even MORE than that shepherd loved his one, little lost sheep.

GOD'S WORD & ME

The Bible says, "Discover how wide and deep is the love of Christ." Who did God send to Earth to show His love? That's right, Jesus! God sent Jesus to make it possible for us to join His family! Jesus always loves us, no matter how young or old we are. Pray, Thank You, God, for loving us more than the shepherd loved his sheep. Thank You for sending Jesus so we can join Your family. In Jesus' name, amen.



DEPEND ON
GOD'S LOVE

BIBLE STORY CENTER

FOR OLDER CHILDREN •
MATTHEW 18:12-14; LUKE 15:3-7

INTRODUCTION

Let's play a game of "first word." I'll say a word. Then you say the first word that comes to your mind. Begin with several words related to farming (tractor, fence, barn, silo) and then words related to raising sheep (pasture, wool, milk, sheepfold, shepherd). Enjoy the silly answers you may hear! Today we're going to find out what Jesus said about some sheep—and a shepherd who loved them!

What do you think is in our Adventure Box today? Let's find out!

Untie box. Remove items from box and use them to demonstrate story action as you tell the story.

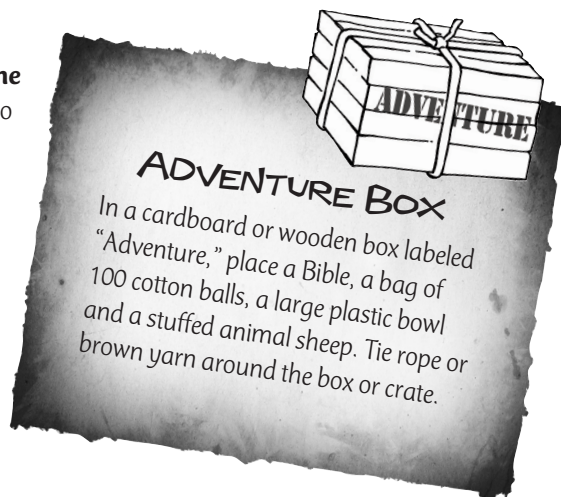

TELL THE STORY

One day Jesus was talking to people about God. There were all kinds of people there—kids and old people, tall and short people, happy people and sad people—everyone wanted to hear Jesus talk about God's love. There were also religious leaders there. But they were sure that SOME of the people who had come should NOT be there.

"Humpf! Do you see that?" One of the religious leaders probably said to his friends. He pointed to a group of tax collectors and other sinners—people known to have done bad things—who had come to join the group listening to Jesus. "This Jesus welcomes SINNERS and TALKS to them! He lets evil tax collectors stand alongside GOOD people like us."

"Jesus should know better," another may have said. "Tax collectors are just thieves. We shouldn't have to be NEAR them! Not only that, Jesus actually had dinner at the home of Levi the tax collector. Can you imagine? He eats with SINNERS and then expects us to learn about God from HIM!"

Jesus knew what the religious leaders were saying. Jesus also knew that they didn't understand that THEY were sinners, too! God had sent Jesus to show love to ALL people—people who thought they were just fine and people who knew they were NOT! So Jesus told a story to help everyone understand why He had come to Earth.

This story was about a shepherd who had 100 sheep. (*Open bag of cotton balls and scatter them among children.*) This shepherd took very good care of his sheep. Every day he took the sheep to places where they could find good things to eat and clean water to drink. He watched to be sure they didn't eat or drink anything that might make them sick. Every night he used his shepherd's crook to gather the sheep together and lead them to a place where they would be safe. And every day he counted his sheep to make sure that not one of them was lost.

(*Pass bowl so children can place cotton balls in it.*) One day, the shepherd was counting his sheep. Everything was going fine until he got to the end: "95, 96, 97, 98, 99 . . ." Wait, a minute, the shepherd must have thought, *Why are there only 99 sheep? Maybe I made a mistake counting.* The shepherd started counting all over again, but there were STILL only 99 sheep. That meant one of the sheep was MISSING!

Now some shepherds might have said, "Oh, well, too bad," and gone to eat their dinner. But not THIS shepherd! He left the 99 sheep he'd already counted and went out to find his one missing sheep. That one sheep was VERY important! (*Remove and show one cotton ball; place it behind your back.*)

The shepherd walked and looked. He peered down cliffs and into creek beds. *Where could that sheep have fallen?* he wondered. He searched behind big rocks, up hills and along roads. He pushed back branches and looked under bushes. He searched EVERYWHERE for his lost sheep. Every few minutes, he called for his sheep. He paused to listen, hoping he would hear his lost sheep bleating.

Finally, he DID hear a little sound—what was it? Yes! It sounded like a sheep bleating! The shepherd was so happy! He called even louder and followed the sound of the sheep's bleating until he could see his lost and frightened sheep. He wrapped his arms around the sheep and hugged its neck. (*Use stuffed animal sheep to illustrate actions.*) He picked up the sheep and gently laid it across his shoulders. He carried it all the way back to the place where his other sheep waited. He was DELIGHTED that he'd found his sheep!

The shepherd went to his friends and neighbors. He said, "Come and see! Come and see! My lost sheep has been FOUND!" And all his friends and neighbors celebrated.

Then Jesus explained the story. He said that God is like the shepherd. Before we become members of God's family, we are like the lost sheep. When people believe in Jesus, receive God's forgiveness and become part of God's family, God is SO happy that He and Jesus, the angels and everyone in heaven CELEBRATE!

GOD'S WORD & ME

We all want to do things our own way instead of God's way. Doing these wrong things is sin. And sin separates us from God. Without God, we are lost. So God sent Jesus to bring us into God's loving family. Jesus did that by dying on the cross to take the punishment for the wrong things we've done. We call Jesus the Savior because He saves us from this punishment. Jesus wanted to make a way for us to be forgiven for the wrong things we do.

It was terrible when Jesus died, but Jesus didn't stay dead. Three days later, Jesus rose again. And Jesus lives today! (See Luke 24.) **It's so good to know that because of Jesus' love and life, sin can't separate us from God.**

- Invite a child to read Ephesians 3:17-18 aloud. **This is a prayer Paul wrote for his friends in Ephesus. What words does he use to describe Christ's love?** (High. Wide. Long. Deep.) **Why do you think he used those words?**
- **What words would you use to tell how big God's love is for you?**
- **What ways did God show us His love?** (Jesus died and rose again; we can live with Him forever. When we believe in Jesus as our Savior, we're part of God's family!) **There is no love bigger than that!** (Invite children interested in knowing more about becoming members of God's family to talk with you or another teacher after class. See "Leading a Child to Christ," p. 12.)
- **Let's thank God for His amazing love.** Pray with children, thanking God for sending Jesus and inviting Him to help children understand how much He loves them!



GAME CENTER

FOR YOUNGER CHILDREN • MATTHEW 18:12-14; LUKE 15:3-7

COLLECT

Bible, blocks, cotton balls (at least five for each child).

PREPARE

If possible, before children come into the room, hide cotton balls around the room. (Optional: Hide cotton balls in an outdoor playground.)

DO

1. Invite children to help you build a sheep pen from blocks.
2. At your signal, children search around the room to find the lost "sheep" and bring them to the sheep pen. Have children sit by sheep pen when they have found a specified number of sheep.

TALK ABOUT

- Jesus told a story about a shepherd who went looking for a lost sheep. The shepherd looked for the sheep because he loved the sheep. Jesus said that God loves us even more than the shepherd loved the sheep! How many lost sheep do you think you can find in our room today?
- The Bible says, "Discover how wide and deep is the love of Christ." This verse means that God's love for us is great! Because God loves us, He helps us have good food to eat and moms and dads to take care of us. Elias, what is something your dad does to take care of you? Jessica, what does your grandma do to help you?
- I'm glad God loves me and helps me have good food to eat. What is your favorite food to eat for lunch?
- Pray briefly, Dear God, thank You for Your amazing love. Help us remember all the ways You show Your love to us. In Jesus' name, amen.

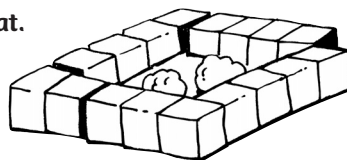

GOD'S WORD

"I pray that you, being rooted and established in love, may have power, together with all the saints, to grasp how wide and long and high and deep is the love of Christ."

Ephesians 3:17-18

FOR YOUNGER CHILDREN:

"Discover how wide and deep is the love of Christ."

GOD'S WORD & ME

Nothing we do can change
God's generous love for us.

FOR OLDER CHILDREN

Children gather lost "sheep" by playing a relay. Place all the sheep on one side of the room or open playing area. Children form teams and line up across the room or playing area from the sheep. To gather a sheep, players on each team take turns moving to the sheep by holding onto his or her ankles while walking to the sheep and then running back with the "sheep" in hand. Teams see how many sheep they can retrieve in a specified time.

GAME CENTER

FOR OLDER CHILDREN • MATTHEW 18:12-14; LUKE 15:3-7

COLLECT

Bible, Lesson 5 Pattern Page (p. 112), paper in at least two colors, scissors.

PREPARE

Copy Lesson 5 Pattern Page onto paper and cut apart to make verse cards. Make a set of cards in a different color for each group of up to eight players.

DO

1. Play a game like Steal the Bacon. Divide group into two or more teams. Teams line up shoulder-to-shoulder on opposite sides of the playing area. Place verse cards you prepared in center of playing area and assign each team a color of cards.

2. Assign rainforest animals to children (jaguar, monkey, parrot, toucan, ocelot, gorilla, dart frog, chameleon). Repeat animal names for each team.

3. Call out two animal names. Children with those names run to the center of playing area and collect a card of their team's assigned color. When all cards have been collected, teams put cards in order and read verse aloud. Return cards to center of playing area, mix them up and play again.

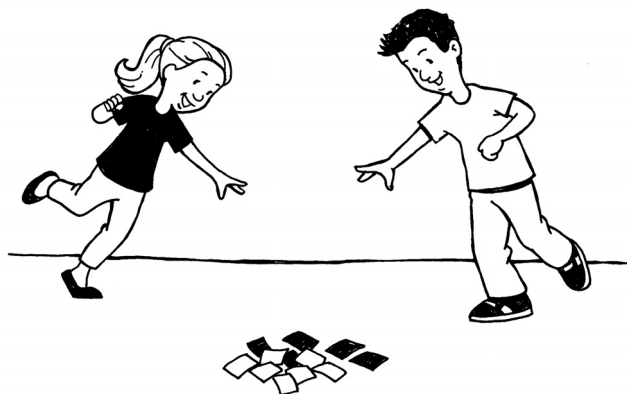

GOD'S WORD

"I pray that you, being rooted and established in love, may have power, together with all the saints, to grasp how wide and long and high and deep is the love of Christ."

Ephesians 3:17-18

FOR YOUNGER CHILDREN:

"Discover how wide and deep is the love of Christ."

GOD'S WORD & ME

Nothing we do can change
God's generous love for us.

TALK ABOUT

- Read verse aloud. **How would you say this verse in your own words? Why do you think it's so important to know and understand how much God loves us?** (In tough times we can rely on God's love. When we feel like no one cares about us, it helps to remember God's love.)
- **When are some times people today might need to remember God's love?** (When they are worried about what might happen in the future. When they have to move to a new city or go to a new school.)
- **Who is someone you think needs to know and understand how great God's love is?** Lead children in prayer, thanking God for His love and pausing to allow children to pray silently for others to know God's love.

FOR YOUNGER CHILDREN

Number the verse cards in order. After children have collected the cards, they put them in number order, and then turn them over to read the words.

ART CENTER

FOR YOUNGER CHILDREN • MATTHEW 18:12-14; LUKE 15:3-7

COLLECT

Bible, construction paper in a variety of colors, scissors, glue sticks, 2-ft (0.6-m) length of butcher paper for each child.

PREPARE

Cut several sheets of paper at once into a variety of large and small geometric shapes (circles, squares, rectangles and triangles). Make enough for each child to have 15 to 20 shapes.

DO

1. Give each child a length of butcher paper. Child chooses paper shapes and glues to paper to create a picture of him- or herself.
2. Child may use markers to add clothing or facial details. (Optional: Children fringe narrow strips of paper to make hair.)
3. On each child's paper, print the words "God Loves (Delaney)."

TALK ABOUT

• **Mattias**, I see that you chose a blue circle to make your face. What color paper are you going to choose to make your arms and legs? God loves you! God loves you so much He helps you have strong arms and legs.

• The Bible says, "Discover how wide and deep is the love of Christ." This verse means that God's love for us is great! No matter where we go or how old we get, God always loves us. Who are some people younger than you? Older than you?

• Lead children in a brief prayer, **Dear God, thank You for Your wonderful love. Thank You for all the people You have given to care for us. In Jesus' name, amen.**

FOR OLDER CHILDREN

Prepare only small geometric shapes. Each child glues the shapes to paper, designing a scene picturing a way God has shown love to him or her (family members, item in creation, favorite food, friends, etc.).

GOD'S WORD

"I pray that you, being rooted and established in love, may have power, together with all the saints, to grasp how wide and long and high and deep is the love of Christ."

Ephesians 3:17-18

FOR YOUNGER CHILDREN:

"Discover how wide and deep is the love of Christ."

GOD'S WORD & ME

Nothing we do can change
God's generous love for us.

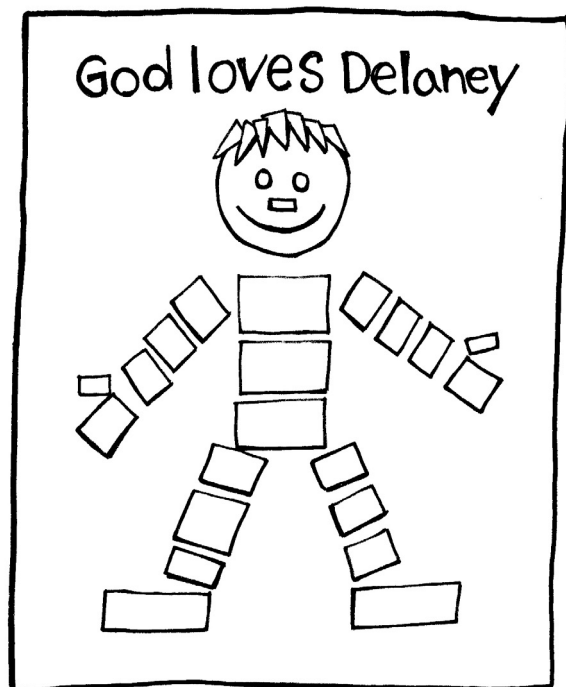

ART CENTER

FOR OLDER CHILDREN • MATTHEW 18:12-14; LUKE 15:3-7

COLLECT

Bible, length of butcher paper, pencil, scissors, white paper, markers, construction paper, tape.

PREPARE

Print "Look for God's Love" across the top of butcher paper and cut out several sizes of squares in the paper. Make a cutout for each child. Then cut two pieces of construction paper to fit each square. (For a large group, prepare more than one paper.)

DO

1. Lead children in listing as many ways as they can in which God shows love to them (family, friends, foods, animals, creation, abilities, etc.). Ask each child to choose an item.
2. Have each child choose a cutout on the butcher paper. Child draws a picture of his or her chosen item on paper which will fit the size of the cutout.
3. After drawing picture, help child tape picture behind the paper. Child also tapes a sheet of construction paper as a flap covering the picture. (Optional: Child writes his or her name on the flap.) Display completed project where children and parents can lift flaps to see items that remind them of God's love.

TALK ABOUT

- **What do you see every day that reminds you of God's love?** (Family. Friends. Trees. Pets.)
- **What difference do you think it would make in our town if everyone knew about God's love? How might people act if they are depending on God's love?** (They might worry less about the future. They treat others better because God's love is for everyone.)
- **We've been talking about God's love today. What words would you use to describe God's love? How many different words do you think we can think of?** (Everlasting, awesome, wonderful, great, good, amazing, super.)
- **When might kids your age think that God doesn't love them?** (When they've done something wrong. When no one has told them about God's love.) **Think about a time it will help you to remember that God loves you.** Pray, thanking God for His love.

FOR YOUNGER CHILDREN

Children draw pictures of items on separate sheets of paper. Help children tape blank papers on top of their pictures, taping only across the top to create flaps.

GOD'S WORD

"I pray that you, being rooted and established in love, may have power, together with all the saints, to grasp how wide and long and high and deep is the love of Christ."

Ephesians 3:17-18

FOR YOUNGER CHILDREN:

"Discover how wide and deep is the love of Christ."

GOD'S WORD & ME

Nothing we do can change God's generous love for us.

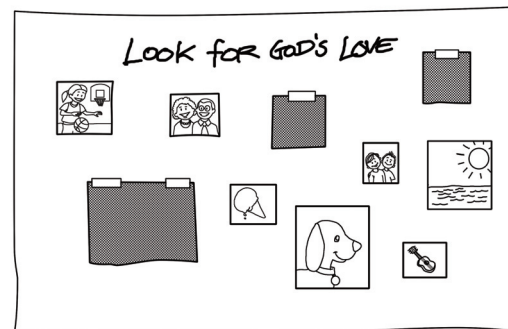

WORSHIP CENTER

MATTHEW 18:12-14; LUKE 15:3-7

COLLECT

Bibles, *Parable Quest* CD-ROM and CD player, song charts (pp. 247, 250), whistle.

TEAM GAME

Divide group into two teams. Each team selects up to eight players to compete in a rainforest animal relay. Players line up at one side of an open area. At your signal, players run to opposite side of playing area and back. Every time you blow a whistle, players must stop and perform the action of a rainforest animal before continuing. Blow the whistle more frequently to increase the challenge. Play several rounds as time and interest permit, changing the action that players perform when you blow the whistle (jump like a jaguar, spin like a butterfly, flap arms like a parrot, swing arms like a monkey, etc.).

BIBLE VERSE GAME

Repeat Ephesians 3:17-18 aloud with children. Then invite volunteers to suggest as many motions for words in the verse as possible. As each motion is suggested, children practice the motion. End by saying the verse and doing all the motions.

SONG

You, or another leader, lead children in singing "Forgiving and Good," adding motions and/or clapping if desired.

PRAYER

What good thing has God made or provided for us that begins with the first letter of your name? Children tell answers. Lead children in prayer, thanking God for His love to us. In your prayer, mention the good things children suggested.

SONG

You, or another leader, lead children in singing "God Gave," adding motions and/or clapping if desired.

GOD'S WORD

"I pray that you, being rooted and established in love, may have power, together with all the saints, to grasp how wide and long and high and deep is the love of Christ."

Ephesians 3:17-18

FOR YOUNGER CHILDREN:

"Discover how wide and deep is the love of Christ."

GOD'S WORD & ME

Nothing we do can change
God's generous love for us.

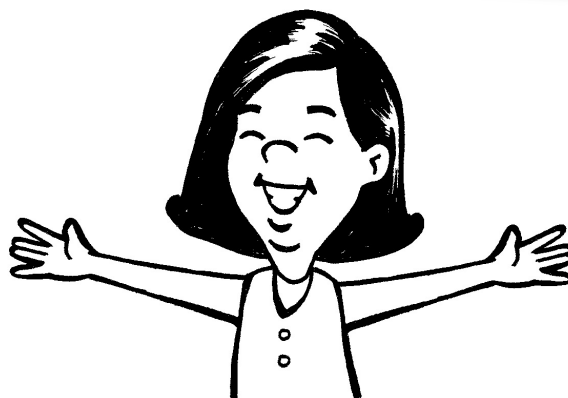

wide

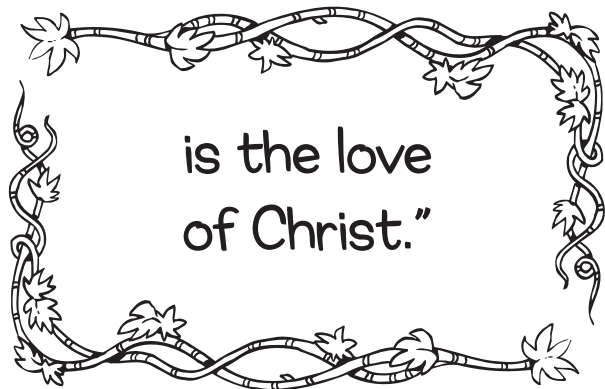
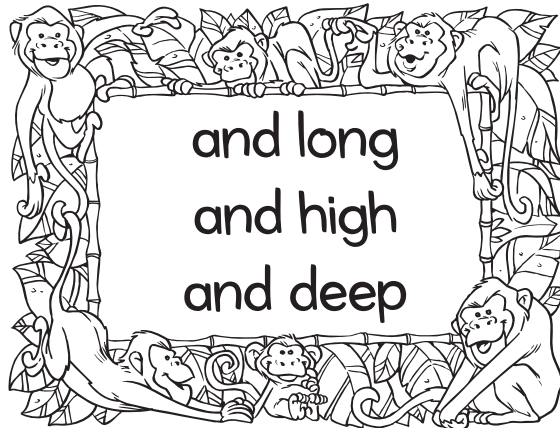
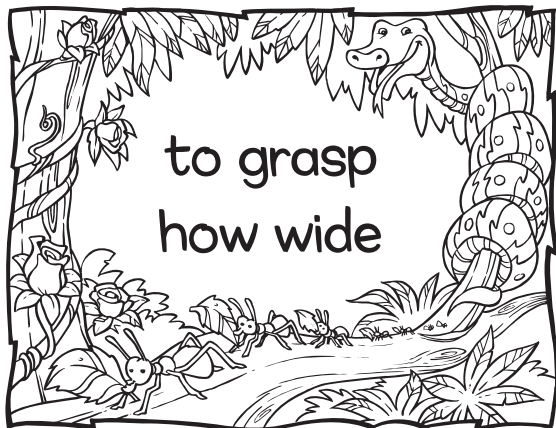
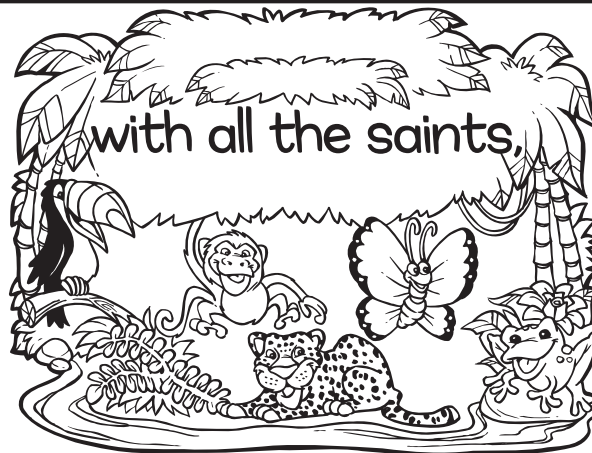
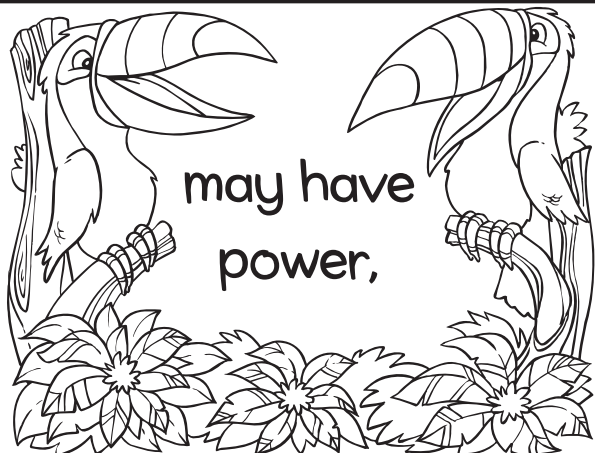
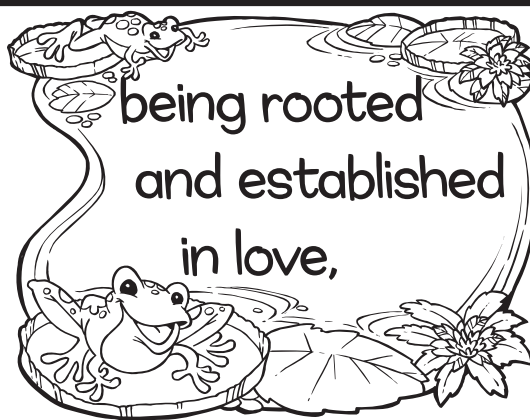
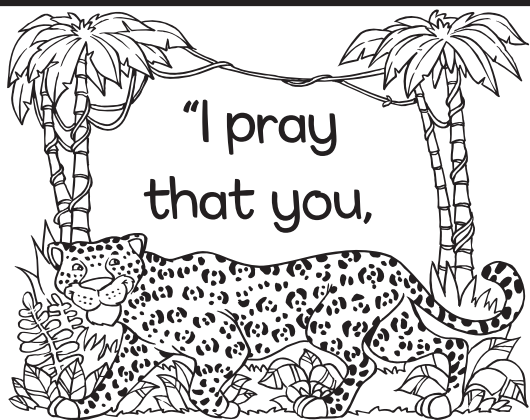

Jesus tells the story of the lost sheep.

Matthew 18:10-14; Luke 15:3-7



The shepherd loved his sheep. How does God show love to you?

Big, Big Tree!

Unscramble the letters to fill in the blanks. Then read UP from the bottom for the message!

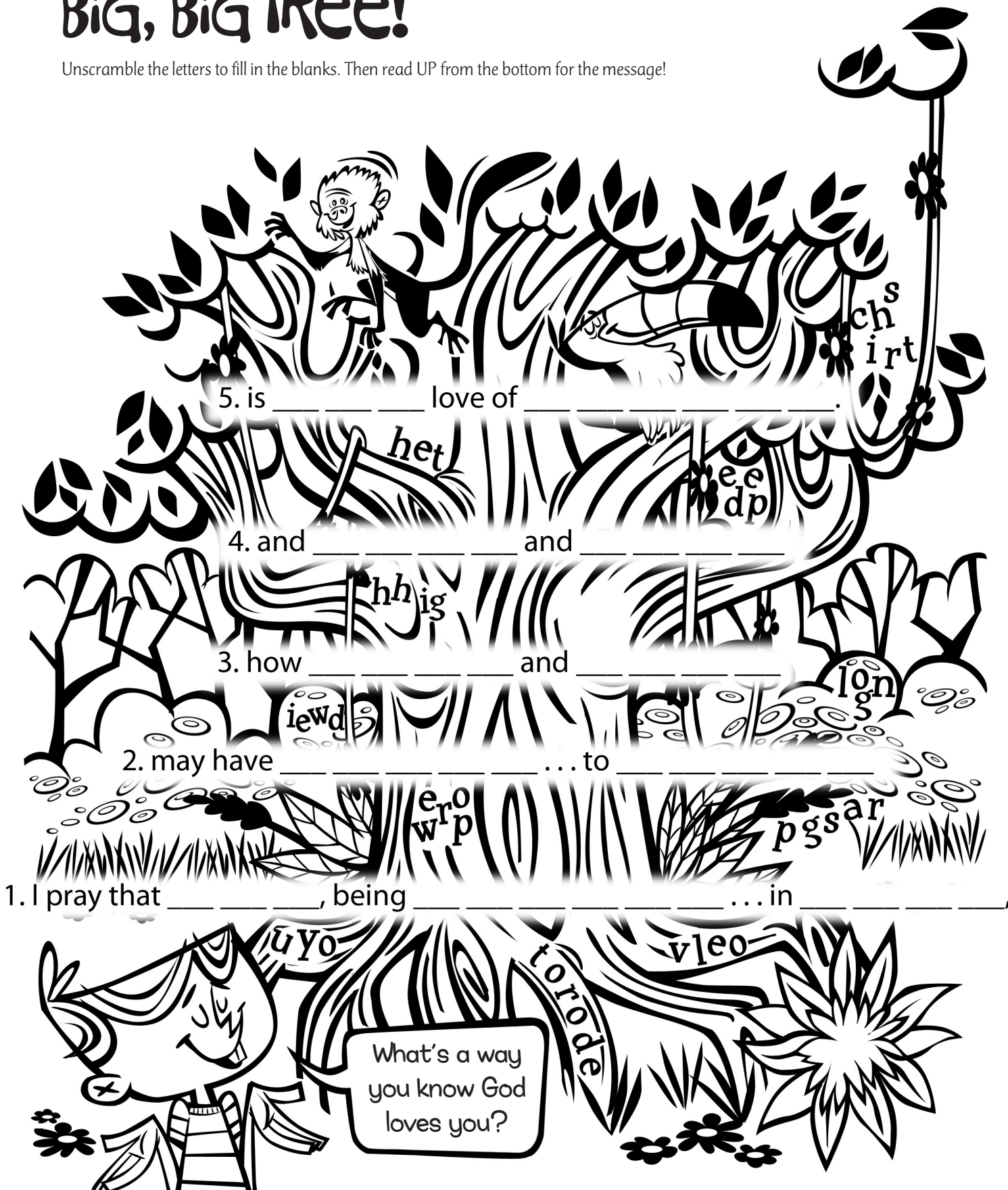

UNFORGIVING SERVANT

MATTHEW 18:22-35



SHOW
MERCY

Teacher's Devotional

Do you think most people really believe in the kind of forgiveness God shows us? We agree that the unforgiving servant should have been much more merciful—but in our own lives, unlimited forgiveness isn't so popular. After all, shouldn't people be held accountable? Shouldn't our rights be protected? Consider: Is Jesus' teaching at odds with our cultural (or spiritual) values?

Most of what we hear and read focuses us on our individual rights rather than on the power of forgiveness. But look at Jesus instead: Under both Roman and Jewish law, He had the right to a fair trial, to own a home, to marry. However, Jesus chose to lay down these rights and many rights far greater (see Philippians 2) to accomplish our redemption. He chose to fully and unconditionally forgive even His murderers (see Luke 23:34) in pursuit of that redemption. First John 3:16 tells us that His behavior defines love—and its effect is far more powerful than winning any challenge to personal rights or holding any person to account. Such transforming forgiveness flows only from the heart of God—or from our own hearts as we are empowered by His Spirit!

We are called to live out kindness, compassion and forgiveness simply because we are forgiven. From whom are you holding back your forgiveness? Release that person. Give the situation to God. Let Him be the judge! Removing any root of bitterness first frees you and then releases others you didn't even realize were affected (see Hebrews 12:15). Instead of fearing you'll lose out, exercise your faith: Trust that God's ways are beyond ours and that His forgiveness is far more powerful than any personal right we could ever hold.

GOD'S WORD

"Be kind and compassionate to one another, forgiving each other, just as in Christ God forgave you."

Ephesians 4:32

FOR YOUNGER CHILDREN:

"Be kind and forgive each other."

GOD'S WORD & ME

Because there is no limit to God's forgiveness for us, we can always show His mercy to others.



PLANNING PAGE

Choose which centers you will provide and the order in which children will participate in them (see pp. 14-18 for schedule tips and pp. 24-25 for guidelines in combining older and younger children). Also plan who will lead each center (for staffing tips see pp. 19-21). Use the reproducible planning sheet (p. 238) to record your plans.

BIBLE STORY CENTER

BIBLE STORY

Unforgiving Servant • Matthew 18:22-35

ADVENTURE BOX (YOUNGER CHILD)

Use props (toy or paper crown and three papers plates on which are drawn a sad face, a happy face and an angry face) to demonstrate story action

ADVENTURE BOX (OLDER CHILD)

Use props (toy or paper crown, a large paper bag stuffed with newspaper and stapled shut, a small lunch bag stuffed halfway with paper and stapled shut) to demonstrate story action

GAME CENTER

YOUNGER CHILD OPTION

Play a game like Hot Potato to talk about the Bible story and ways to be kind when others have been mean

MATERIALS

Bible, Lesson 6 Pattern Page (p. 126), *Parable Quest* CD-ROM and player, scissors, paper bag or shoe box

OLDER CHILD OPTION

Hit targets with discs to put the words of Ephesians 4:32 in order and tell ways to obey the verse by forgiving others

MATERIALS

Bible, large Post-it Notes, markers, for each team—a round plastic lid

ART CENTER

YOUNGER CHILD OPTION

Make and play maracas and talk about what it means to forgive others

MATERIALS

Bible, *Parable Quest* CD-ROM and player, stickers, craft foam adhesive shapes, dried beans or unpopcorned popcorn kernels, painter's tape; for each child—two large colorful plastic cups

OLDER CHILD OPTION

Make wristbands to wear as reminders to show mercy and forgiveness to others

MATERIALS

Bible, 1¼x10-inch (3.1x25.5-cm) strip of craft foam for each child, scissors, several colors of plastic tape or electrical tape and/or small stickers

COLORING/PUZZLE CENTER

YOUNGER CHILD OPTION

Review the Bible story while completing coloring page

MATERIALS

Lesson 6 Coloring Page (p.127) for each child, crayons

OLDER CHILD OPTION

Review Ephesians 4:32 while completing puzzle page

MATERIALS

Lesson 6 Puzzle Page (p. 128) for each child, pencils

WORSHIP CENTER

FOR THE YOUNGER AND OLDER CHILD

Participate in large-group activities to review Bible verse and to worship God together

MATERIALS

Bibles, *Parable Quest* CD-ROM and CD player, song charts (pp. 251-252)

BONUS THEME IDEAS

Bonus Theme Ideas can be used at any time during this session: as an additional activity center, to extend the session for a longer time, or for added theme excitement.

BUG CREATIONS

In separate containers, provide vanilla wafers, vanilla frosting and several of the following decorative items: colored sugar, colored O-shaped cereal, sprinkles, mini cake decorations and gel icing. Set out plastic spoons and knives. Children create their own rainforest bugs by spreading frosting on wafers and then using the decorative items to create eyes, mouth, legs and ears.

Post a note alerting parents to the use of food. Also, check registration forms for possible food allergies.



RAINFOREST VISITORS

Arrange for one or more "visitors" from the rainforest to come to *Parable Quest*. Consider these sources: (1) someone in your church congregation who has a pet bird (parrot, toucan or macaw), frog or iguana; (2) a local pet store or zoo that would be willing to loan an animal for display. Ask the pet owner to briefly describe the animal. (Optional: Have each child's picture taken as he or she stands near the animal.) If live animals aren't an option, find on the Internet one or more short videos of rainforest animals to show children.

RAINFOREST SOUVENIR

Help each child make a fun dragonfly souvenir to take home as a reminder of *Parable Quest*. Ahead of time, glue two craft sticks to a tongue depressor to form body and wing outlines of dragonfly. Allow glue to dry. Children cut tissue paper to fit wings and use glue stick to glue paper onto wing outlines. (Optional: For younger children, pre-cut wings.) Children glue small pom poms to body and small wiggly eyes to head. Small pieces of chenille wire can be glued on for antennae.

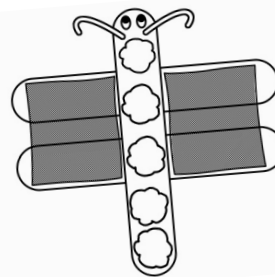

BIBLE STORY CENTER

FOR YOUNGER CHILDREN • MATTHEW 18:22-35

INTRODUCTION

Welcome your rainforest explorers by saying, **Let's play a game and walk like animals in the rainforest.** Have children stand in a circle. Ask them to move like each of the following animals: hop like a frog, pounce like a jaguar, fly like a parrot, slowly walk like a sloth, swim like a fish, etc. Then show Adventure Box. **What do you think is in our Adventure Box today? Let's find out!** Untie box. Remove items from box and use them to demonstrate story action as you tell the story.



ADVENTURE BOX

In a cardboard or wooden box labeled "Adventure," place a Bible, a toy or paper crown and three papers plates on which are drawn a sad face, a happy face and an angry face. Tie rope or brown yarn around the box or crate.

TELL THE STORY

One day, Jesus' friend Peter wanted to know what he should do when someone had been mean to him. Listen to what Jesus said Peter should do when someone had been unkind.

Once there was a man who worked for a king. *(Invite one child to wear the toy or paper crown.)* This man had asked the king for lots and lots of money and had promised that he would pay it all back. One day, the king told this man, "Pay back all the money you borrowed from me. And pay me right now!" But the man didn't have the money. How do you think the man felt? *(Invite a volunteer to choose and show the "sad" plate face.)*

The king called one of his helpers. The king told his helper, "Since this man cannot pay me, take everything he has, sell it and give that money to me!" How do you think the king felt? *(Volunteer chooses and shows the "angry" plate face.)*

The man fell to his knees. "No! No!" the man cried. "I promise to pay you back!" The king changed his mind. He felt sorry for this man. "I FORGIVE you," said the king. "You do not have to pay back ANY of the money." How do you think the man felt now? *(Volunteer chooses and shows the "happy" plate face.)*

The king had been so kind! He had FORGIVEN the man. Now you would think that the man would be happy and kind, too. But on the way home, the man saw a friend. This friend had borrowed just a LITTLE money from him. Instead of being kind and happy, the man grabbed his friend. How do you think the man looked? *(Volunteer chooses and shows the "angry" plate face.)*

He shouted at his friend, "Pay back the money you owe me! Pay it back right now." How do you think the man's friend felt? *(Volunteer chooses and shows the "sad" plate face.)*

The friend got down on his knees. His friend begged, "Please wait for a little while. I promise to pay you back." But the man would NOT forgive his friend. The man had his friend put in jail!

The king heard how the man had NOT forgiven his friend. How do you think the king's face looked when he heard this? *(Volunteer chooses and shows the "angry" plate face.)* The king was so angry that he sent the unkind man to jail.

After the story, Jesus told Peter, "God is like the king. God forgave you a lot. So God wants you to ALWAYS forgive other people."

GOD'S WORD & ME

I am so glad that God forgives me when I have done something wrong. And because God loves me so much, He wants me to show His love and forgive others when they do wrong. We can say kind words when others have been mean. Pray, Dear God, thank You for loving us. Please help us to love others and forgive them. In Jesus' name, amen.



BIBLE STORY CENTER

FOR OLDER CHILDREN • MATTHEW 18:22-35

INTRODUCTION

Let's guess letters to discover some words we'll see in our story today.

Draw a blank line for each letter in this equation: "Debt = I owe money." Children guess letters of the alphabet. Write correct letters on the blanks. When children have discovered the phrase, invite several volunteers to tell about a time they owed money. **Listen to find out what happened to a man who owed a LOT of money—to a king!**

What do you think is in our Adventure Box today? Let's find out!

Untie box. Remove items from box and use them to demonstrate story action as you tell the story.



ADVENTURE BOX

In a cardboard or wooden box labeled "Adventure," place a Bible, a toy or paper crown, a large paper bag stuffed with newspaper and stapled shut, a small lunch bag stuffed halfway with paper and stapled shut. Tie rope or brown yarn around the box or crate.

TELL THE STORY

One day when Jesus was talking with His disciples, Peter asked Jesus, "Lord, how often should I forgive a person who sins against me? Is it enough to forgive the person seven times?" Peter probably thought that it was very GENEROUS to forgive someone seven times!

But Jesus told Peter that he needed to forgive MANY more times than seven! Then Jesus went on to tell Peter a story to help him understand. (*Invite three or more volunteers to pantomime story action as you tell the story. Give crown to child who will act as king.*)

Once, a king was checking on how much money people owed him. He discovered that one of his servants owed him lots and lots and LOTS of money. Over time, this servant had borrowed FAR more than he could ever repay! (*Show large bag and then give it to person playing the part of the servant.*)

The king called for this servant to come to him. He said to the servant, "It's time to pay back all the money you have borrowed from me!" But the servant didn't have the money. He couldn't POSSIBLY pay this debt!

The king called his guards and said, "This servant cannot pay what he owes me. Take him, his wife his family and everything he has—and SELL them. Let's get this debt PAID!"

The servant fell to his knees. "No! No!" he begged the king. "Please, be patient with me. I promise I'll pay you everything I owe!"

The king looked at his servant—he was sweating and crying and scared! The king changed his mind. He said, "I forgive you. Your debt is gone. You do not have to pay back ANY money. You may go home, FREE of your debt."

Can you imagine how AMAZED the servant must have been? WOW! In one moment, his whole life was changed! He no longer had to live with all that WORRY about the money he couldn't pay back. He was saved from losing his home and his family. He was saved from becoming a SLAVE!

The servant must have skipped out of the palace! The king had been so kind! He had FORGIVEN him! Now, you might think that the servant would be SO happy and that he couldn't WAIT to be kind to someone else! But on the way home, the man saw a friend of his. (*Show small bag and then give it to person playing the part of the friend.*)

This friend had borrowed just a LITTLE money from this servant. And instead of being kind and happy, the servant GRABBED his friend. He began to choke him, shouting, "Pay back the MONEY you owe me! Pay it back RIGHT NOW!"

His friend fell to his knees. "No! No!" he begged the servant. "Please, be patient with me. I promise I'll pay you everything I owe!" But the servant would NOT forgive his friend. Instead, he had his friend put in JAIL because he owed him the money! But other people saw what the servant had done to his friend. They were upset to see the way the servant treated a friend who owed him only a LITTLE money! These people went to the king and told him what they saw.

Well, when the king heard what his servant had done to his friend, he called for the servant to come to see him AGAIN. The king said, "You are a wicked servant. I forgave you ALL the money you owed me because you begged me to. But I know what you did to your friend—you would not forgive him even a SMALL debt! Shouldn't you have forgiven his debt like I forgave yours? I had mercy on you—you should have had mercy on him!" The king was very angry. He sent this mean, unforgiving servant to jail!

After the story, Jesus said, "God is like the king. God forgives you for EVERYTHING. He expects you to treat others the way He has treated you—with forgiveness and mercy! So God wants you to ALWAYS forgive other people."

GOD'S WORD & ME

It's really easy to look at other people and think that they should forgive us, isn't it? But because God forgave us of ALL our sins, He want us to treat other people in the same way He has treated us! When we show forgiveness and mercy, we are showing our family likeness to God our Father! He wants us to be known for our forgiveness and mercy!



• **What do you think the servant would have told you if you'd visited him in jail?**

(It's good to be forgiven. And it's a good idea to forgive.)

• Invite a child to read aloud Ephesians 4:32. **Why does this verse say we should forgive others?**

• **What are some times it is really hard to forgive another person?** (When the person breaks a promise, tells a lie about you or hurts you.) Allow a short time for children to silently forgive people they need to forgive. Pray with children, asking God to help them forgive others.



GAME CENTER

FOR YOUNGER CHILDREN • MATTHEW 18:22-35

COLLECT

Bible, Lesson 6 Pattern Page (p. 126), *Parable Quest* CD-ROM and player, scissors, paper bag or shoe box; optional—markers, paper clips.

PREPARE

For each group of six children, make two copies of Lesson 6 Pattern Page on different colors of paper. Cut apart the page to make sets of Bible story cards. (Optional: Make a copy of the page for each child.)

DO

1. Children sit in a circle of up to six players. Give each child a Bible story card. Place another set of cards in bag or box.
2. When you play "Love Never Fails," children pass bag or box. After 10 to 20 seconds, stop the music. Child holding the bag or box removes one Bible story card and places it faceup in the middle of the circle and tells what is happening in the picture. Child with matching card places it on top of the first card. Continue until all cards have been removed from the bag or box.
3. Children place cards in Bible story order. Collect cards and repeat game as time and interest allow. (Optional: Each child colors a set of cards to take home. Fasten cards together with paper clip.)

TALK ABOUT

- Jesus told a story about a king who was kind. Jesus told this story to help us remember to be kind, too. When we forgive someone who has done something wrong to us, we are being kind. Jesus loves us and He wants us to love other people, too.
- What is something mean a kid your age might do to someone else? (Not want to share. Not take turns.) The Bible says, "Be kind and forgive each other." When someone does something wrong, we can say "stop" and get a teacher or parent to help us. Then we can treat the person kindly. When we are kind, we show mercy.
- What is something kind a kid your age might do? (Let someone choose first. Say kind words. Help someone do a chore.)
- Who is someone you can be kind to? Pray briefly, Dear God, please help us forgive others and be kind. In Jesus' name, amen.

FOR OLDER CHILDREN

Make a set of Bible story game cards for each child and lead children to play a game like Pit. Shuffle all cards together and give six cards to each child. At your signal, children begin trading their cards, calling out the number of cards they are trading and trying to get a set of six matching cards. When a child has collected a set of six matching cards, child stands up and calls out "Show mercy."

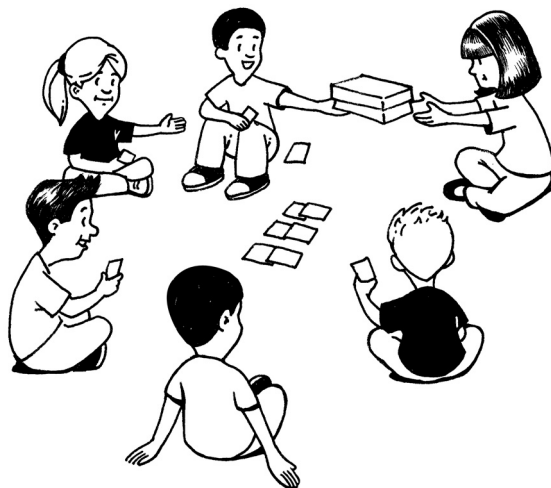
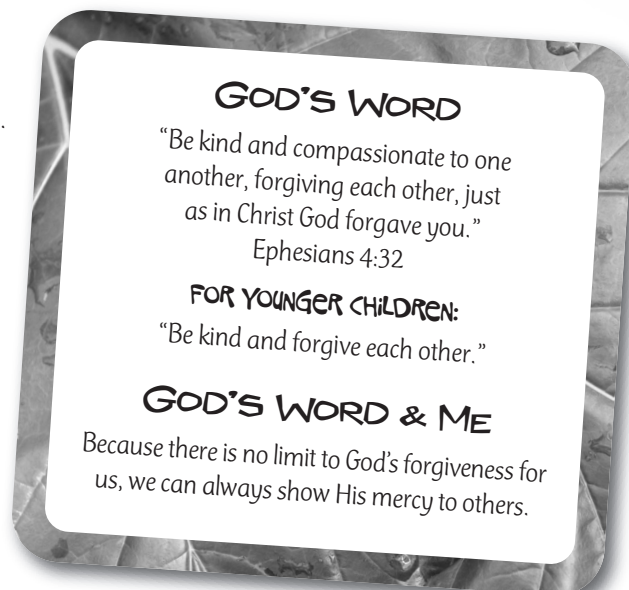

GAME CENTER

FOR OLDER CHILDREN • MATTHEW 18:22-35

COLLECT

Bible, large Post-it Notes, markers, for each team—a round plastic lid; optional—permanent marker.

PREPARE

Write each word of Ephesians 4:32 on a separate Post-it Note, making a set of notes for each team. Place the notes on the floor at one side of the room to mark targets. (Optional: Set up the targets outdoors.)

DO

1. Children form two or more teams of up to eight players each. Teams line up across the room from the targets. Give each team a plastic lid. (Optional: Players on each team choose a team name and write it on the team's lid.)
2. At your signal, first player on each team tosses his or her disc towards the targets. Child collects the target the disc lands on or near. Next players take a turn. Play continues until all targets have been collected.
3. Players on each team assemble the words of the verse in order, showing kindness by trading words as needed with other team(s).

TALK ABOUT

- Read Ephesians 4:32 aloud. **What does this verse say that God has done? Why does God forgive people? What does this verse say that people can do?**
- **How would your school be different if kids obeyed this verse? Your soccer team?**
- **How many examples of ways to obey Ephesians 4:32 can you think of? What are they?**
- **Sometimes we might think that God won't keep forgiving us. But if we ask His forgiveness and help to do right in the future, He does forgive us. He is merciful, even though we don't deserve it.** Lead children in prayer, asking God's help in showing mercy and forgiveness to others.

FOR YOUNGER CHILDREN

Use the verse as paraphrased for younger children: "Be kind and forgive each other." Instead of tossing discs, attach Post-it Notes to wall across an open area of the room. Children form teams of up to six players and take turns running across the room to collect notes, one at a time.

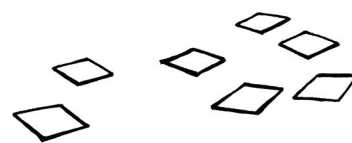
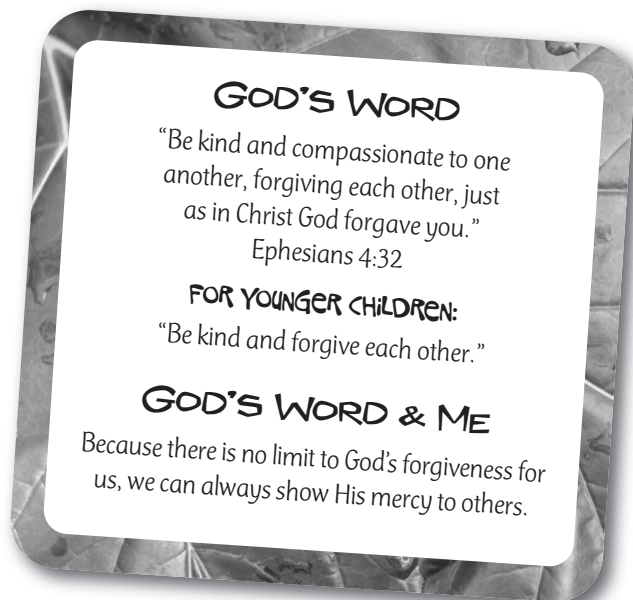

ART CENTER

FOR YOUNGER CHILDREN • MATTHEW 18:22-35

COLLECT

Bible, *Parable Quest* CD-ROM and player, stickers, craft foam adhesive shapes, dried beans or unpopped popcorn kernels, painter's tape; for each child—two large colorful plastic cups.

PREPARE

Make a sample maraca following instructions below.

DO

1. Give each child two cups. Child decorates cups with stickers and adhesive shapes.
2. Child places small handful of dried beans or unpopped popcorn kernels into one cup. Help each child hold cups as you tape the rims together.
3. Play "Forgiving and Good" while children shake their maracas.

TALK ABOUT

• **I see lots of our friends being kind to each other. I see Cameron helping to pick up the cups that fell. I'm glad you know how to be kind. That's what the Bible tells us to do: "Be kind and forgive each other." Who can you be kind to?**

• **Sometimes children don't remember to be kind. When children are mean, how do you feel? (Angry. Sad.) We can ask God to help us be kind, even when someone is mean. What are some kind things we can do? (Use our words to say "stop" instead of hitting or pushing. Wait our turn to play with a toy.)**

• **God is kind to us, even when we do wrong things. God always loves us and will forgive us.** Lead children in prayer, thanking God for His love and forgiveness.

FOR OLDER CHILDREN

Encourage older children to make patterns with adhesive shapes on their cups. Also provide a variety of items which children may use to make sound in their maracas (pennies, rice, paper clips, large pom poms, etc.). Children trade maracas to hear the different sounds. In addition to using maracas while listening to music, children may create rhythmic patterns while saying the words of Ephesians 4:32.

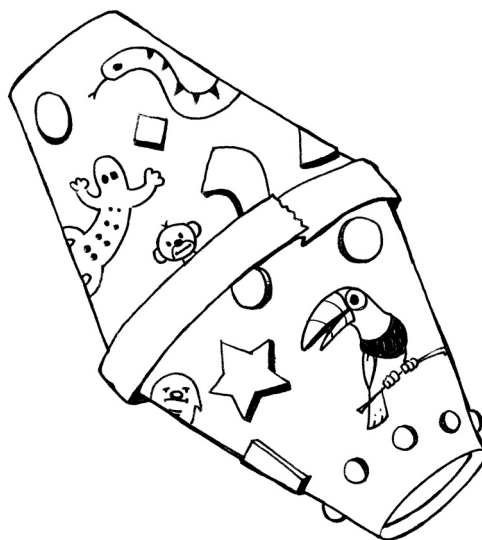
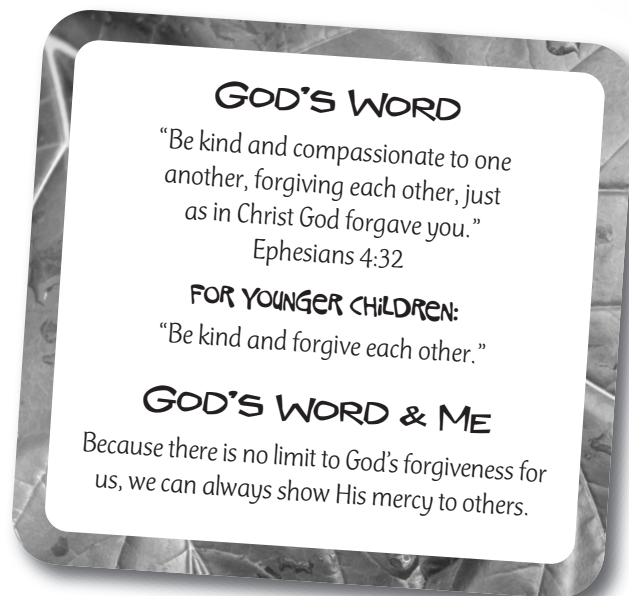

ART CENTER

FOR OLDER CHILDREN • MATTHEW 18:22-35

COLLECT

Bible, 1½x10-inch (3.1x25.5-cm) strip of craft foam for each child, scissors, several colors of plastic tape or electrical tape and/or small stickers.

PREPARE

Make a sample wrist band following directions below.

DO

1. Give each child a strip of craft foam. Child measures strip around his or her wrist and trims it so that there is about 1 inch (2.5 cm) of overlap. Help child as needed to cut a slit in each end of the craft foam so that ends fit together (sketch a).
2. Children choose colors of tape and cut off short strips to wrap around their wrist bands, leaving the ends with slits unwrapped (sketches b and c). Encourage children to create patterns with the tape (squares, diamond-shaped, diagonal stripes, triangles, etc.). Children may also put stickers on their bands.
3. Explain to children that they can wear their wrist bands as reminders to show mercy to others.

TALK ABOUT

- **How would you define the word “mercy”?** (Showing kindness and compassion to someone who doesn’t deserve it.) **Do you think it is hard or easy to be someone who shows mercy? Why?**
- **In what ways have your parents shown mercy and forgiveness to you? What has God done to show mercy and forgiveness to everyone?** Read Ephesians 4:32 aloud.
- **What changes might kids your age want to make in their lives after hearing Ephesians 4:32? Think about how you want your own life and actions to change.** Lead children in prayer, asking God’s help in showing mercy and forgiving others.

FOR YOUNGER CHILDREN

For each child, print the words “Be kind” on a sheet of craft foam or card stock. Children decorate their pages using short lengths of tape and markers. Children take home decorated pages as reminders to obey Ephesians 4:32.

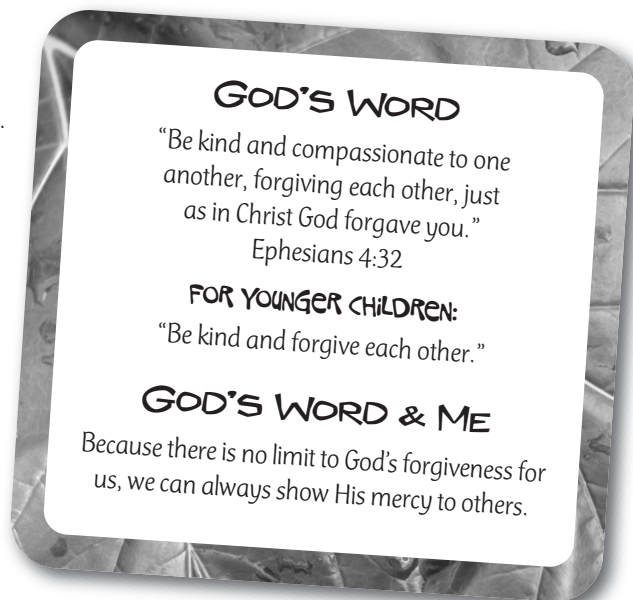

WORSHIP CENTER

MATTHEW 18:22-35

COLLECT

Bibles, *Parable Quest* CD-ROM and CD player, song charts (pp. 251-252).

PREPARATION

Prepare clues for several rainforest animals (see below).

TEAM GAME

Divide group into three or more teams. Give clues one at a time to a variety of rainforest animals. Teams try to guess the animals. For example, for a jaguar you might say these clues: "Has four legs." "Roars." "Has spots." Give the hardest or most general clues first. Other examples are: Monkey—"Good at holding onto things." "Often brown in color." "Makes loud sounds." Frog—"Good at holding onto things." "Can be poisonous." "Has sticky fingers."

BIBLE VERSE GAME

Repeat Ephesians 4:32 aloud with children, dividing it into four phrases. Secretly assign one of the four phrases of the verse to each child. Children move around the room to form groups by whispering their assigned phrases to others, looking for those whose phrases match. When all children have found their group, repeat verse aloud. Play several rounds, or as time permits.

SONG

You, or another leader, lead children in singing "God Forgives Us," adding motions and/or clapping if desired.

PRAYER

Think of some friends you know whom you could help to forgive each other and treat each other with mercy. Lead children in silently praying for these people. End prayer by thanking God for His forgiveness and asking His help in showing mercy and kindness to others.

SONG

You, or another leader, lead children in singing "Love Never Fails," adding motions and/or clapping if desired.

GOD'S WORD

"Be kind and compassionate to one another, forgiving each other, just as in Christ God forgave you."

Ephesians 4:32

FOR YOUNGER CHILDREN:

"Be kind and forgive each other."

GOD'S WORD & ME

Because there is no limit to God's forgiveness for us, we can always show His mercy to others.

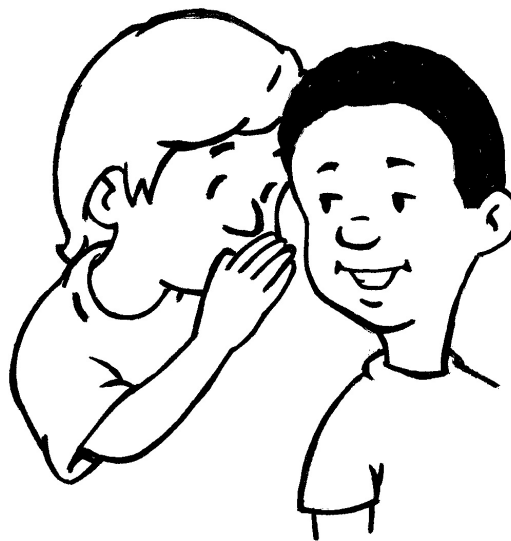



Jesus tells the story of the forgiving king.

Matthew 18:21-35



Who can you forgive? Who can you be kind to?

GOOD SAMARITAN

LUKE 10:25-37



Love in
action

Teacher's Devotional

When we talk about Jesus' story of the Good Samaritan, it is easy to think that we would never emulate the priest or the Levite. But we can relate to these characters, just as did Jesus' audience, because we know people who let other things get in the way of their opportunity to put love into action—and those people may be us! As John points out, love in word is not enough; love is proven through action and in truth (trustworthiness, integrity, honesty).

We're all prone to think we love God or others, whether or not we prove it by action. Like the priest in Jesus' story, we may think it's acceptable to avoid action if we can give a spiritual-sounding reason! After all, consider the priest: He would not have been able to serve in the Temple if he had touched a dead man. Wasn't it more important to be ready to serve God than to save the life of a stranger? Exactly Jesus' point: Saving the life of a battered, bloody stranger IS serving God! And Jesus brings home the point by telling that only a Samaritan (a "half-breed" outsider despised by "good Jews") acted in love.

Your neighbor's race, social position, difficulties or even prejudice toward you may need to be ignored. If we are to love in words and action, we need to love every person our Father places in our path. Such practical love is not easily given, but knowing we have God's supernatural love will allow us to act with His strength to be a neighbor to all those we meet. God has already provided the ability (once we begin, in faith) to work out with our hands the kind of love we profess with our mouths! He is trustworthy and faithful to do it!

GOD'S WORD

"Let us not love with words or tongue
but with actions and in truth."

1 John 3:18

FOR YOUNGER CHILDREN:

"Love others with actions, not just words."

GOD'S WORD & ME

Showing God's love means we do more
than just talk about caring for others:
we put our words into action.



PLANNING PAGE

Choose which centers you will provide and the order in which children will participate in them (see pp. 14-18 for schedule tips and pp. 24-25 for guidelines in combining older and younger children). Also plan who will lead each center (for staffing tips see pp. 19-21). Use the reproducible planning sheet (p. 238) to record your plans.

BIBLE STORY CENTER

BIBLE STORY

Good Samaritan • Luke 10:25-37

ADVENTURE BOX (YOUNGER CHILD)

Use props (four toy people, several lunch-size bags filled with newspaper and taped shut to represent hills, and four or five blocks with which to build an inn) to demonstrate story action

ADVENTURE BOX (OLDER CHILD)

Lead children to either pantomime story actions or participate in a melodrama (using signs with “Boo!” “Groan” and “Yeah” written on them) as the story is told

ART CENTER

YOUNGER CHILD OPTION

Make and decorate houses that picture family members and talk about ways to show love to family members

MATERIALS

Bible, large sheet of paper for each child, markers, 2-inch (5-cm) construction paper circles, glue sticks

OLDER CHILD OPTION

Make and decorate circle collages and discuss ways to show love to others, even when it's hard

MATERIALS

Bible, large sheets of paper, a variety of circular shapes in different sizes (margarine tub lid, potato chip can lid, pot lid, jar lid, plate, cookie cutter, etc.), markers (including black)

GAME CENTER

YOUNGER CHILD OPTION

Say the words of 1 John 3:18 while rolling ball on a towel or piece of fabric and then talk about ways to show love to others

MATERIALS

Bible, large piece of fabric or beach towel and small ball for each group of four to six children

OLDER CHILD OPTION

Collect verse cards while under a “rainforest canopy” and then describe actions that show love to others

MATERIALS

Bible, Lesson 7 Pattern Page (p. 140), scissors, umbrella for each team

COLORING/PUZZLE CENTER

YOUNGER CHILD OPTION

Review the Bible story while completing coloring page

MATERIALS

Lesson 7 Coloring Page (p. 141) for each child, crayons

OLDER CHILD OPTION

Review 1 John 3:18 while completing puzzle page

MATERIALS

Lesson 7 Puzzle Page (p. 142) for each child, pencils

WORSHIP CENTER

FOR THE YOUNGER AND OLDER CHILD

Participate in large-group activities to review Bible verse and to worship God together

MATERIALS

Bibles, *Parable Quest* CD-ROM and CD player, song charts (pp. 246, 252)

BONUS THEME IDEAS

Bonus Theme Ideas can be used at any time during this session: as an additional activity center, to extend the session for a longer time, or for added theme excitement.

RAINFOREST DELIGHT

In separate containers, provide several of these kinds of foods grown in the rainforest: sliced fruit (banana, guava, pineapple, mango or kiwi), coconut flakes, almonds, walnuts and pecans. (Optional: Add a few kid-favorite fruits, too, such as apple and orange slices and grapes.) In each container provide a serving spoon. Give each child a disposable bowl. Child chooses foods and mixes in bowl to create his or her own rainforest delight. (Optional: Child adds a spoonful of whipped cream or yogurt.)

Post a note alerting parents to the use of food. Also, check registration forms for possible food allergies.



ANACONDA STRETCH

The Anaconda is one of the largest snakes in the rainforest. Scientists have even discovered an Anaconda that measured almost 40 feet (12 m)! Have children help you stretch out 40 feet (12 m) of yarn to see just how long that really is. Stretch the yarn outside, or back and forth across the room. Then, for extra rainforest fun, have children lie down next to the yarn. They can count, or estimate, how many children it would take to reach 40 feet (12 m).

WORD POWER

On a large sheet of butcher paper, write the word "rainforest." Attach the paper to a wall or put it on a table. Place several markers near the paper. Children work together to see how many words they can think of using the letters in the word "rainforest." Children write words on the paper.

BIBLE STORY CENTER

FOR YOUNGER CHILDREN • LUKE 10:25-37

INTRODUCTION

Welcome your rainforest explorers by saying, **Let's play a guessing game. I'll describe an animal in the rainforest. When you think you know what it is, make the sound that animal makes! I'm thinking of a rainforest animal that is (big) and (spotted) and it likes to (hide in trees).** Children make a growling sound for a jaguar. **Good growling! You all sound like jaguars!** Continue with several other animals (frog, parrot, toucan, butterfly, monkey, etc.). Then say, **What do you think is in our Adventure Box today? Let's find out!** Untie box. Remove items from box and use them to demonstrate story action as you tell the story. Also pantomime suggested actions.



ADVENTURE BOX

In a cardboard or wooden box labeled "Adventure," place a Bible, four toy people, several lunch-size bags filled with newspaper and taped shut to represent hills, and four or five blocks with which to build an inn. Tie rope or brown yarn around the box or crate.

TELL THE STORY

(On low table or floor, set out stuffed lunch-size bags to represent hills.)

One day, a man asked Jesus, "Who is my neighbor?" Here is the story Jesus told:

A man was on a long trip. (Move toy people to demonstrate story action.) He didn't take an airplane, or a train, or a car; he didn't even take a horse. He walked. In those days, almost everyone walked everywhere!

As the man was walking along, robbers jumped out from behind some rocks. They took his money. They even took his clothes. The robbers beat him up, too! Then they left him there, hurt and all alone! He needed HELP! (Hold head as if hurt.)

Soon, the hurt man heard footsteps. (Hold hand to ear.) The man hoped that this person would help him! But he didn't. He just looked the other way and kept right on walking. (Hold shoulder as if hurt.) Ohhh—his SHOULDER hurt. Who would help him?

Then the hurt man heard MORE footsteps! (Hold hand to ear.) Step, step, step—someone ELSE was coming down the road. Surely this man would stop and help! But he didn't. He just kept on walking. (Hold knee as if hurt.) Ohhh—his KNEE hurt! Who would help him?

Then he heard the clipping, clopping sound of an animal's hooves. This man was a Samaritan. He was called a Samaritan because he came from a place called Samaria. The Samaritan saw the hurt man, just like the others did. But he STOPPED. He got off his donkey and HELPED him!

The Samaritan opened his bag. He gave the hurt man a drink of water. Then he took out oil and cleaned the hurt man's cuts. He bandaged all those hurt places. Then the Samaritan lifted the hurt man up on his donkey and took the hurt man to an inn. (That's a place like a motel.) (Use blocks to build a building representing an inn.)

All night long, the Samaritan took care of the hurt man. He even paid money so that the hurt man could stay a long time and get WELL! (Pay out money.)

Jesus' story was finished. He asked, "Who was a neighbor to the hurt man?" The man answered, "The Samaritan—the one who showed kindness to him." Jesus answered, "That's right! Go and show kindness! You can BE a neighbor to people who need your help."

GOD'S WORD & ME

God loves each one of us very much. And He wants us to be kind and show His love to others. That's a way we can show them God loves them, too! The Bible says, "Love others with actions, not just words." When we help others, we are being their neighbors! Pray, Dear Jesus, thank You for loving us. Please help us to be good neighbors and show Your love to other people. Amen.



BIBLE STORY CENTER

FOR OLDER CHILDREN • LUKE 10:25-37

INTRODUCTION

Introduce the story by leading children to play a game of “Matching Actions.” To play the game say, **I’m going to say one action but do another. I want you to do what I say and not what I do.** Give an instruction like “Pat your head” while doing another action such as clapping. Continue for a minute or two with other instructions and actions. Then say, **It’s hard to hear and do the action I say when I don’t do that action, isn’t it? Today we’re going to find out why Jesus said that showing love is more than saying words—we need to do the actions that match our words, too!**

What do you think is in our Adventure Box today? Let’s find out! Untie box. Remove items from box. Hold up signs as indicated during the story and lead children to respond dramatically.

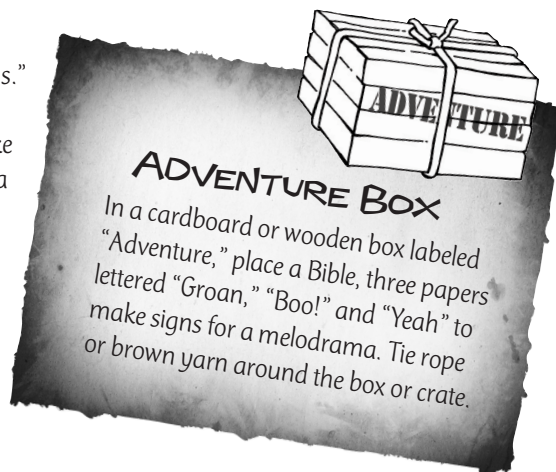

TELL THE STORY

One day a lawyer was talking with Jesus. This lawyer wanted to ask Jesus the most difficult question he could think of. He asked Jesus, “What must I do to inherit eternal life?”

Jesus surprised the lawyer by asking a question of His own! He asked, “What does the Law say?” So the lawyer answered, “Love the Lord your God with all your heart, soul, mind and strength—and love your neighbor as yourself!”

“Good answer!” said Jesus. “If you love God and your neighbor with all you’ve got, you’ll live forever!”

But this man wanted to know even more. He may have been looking for a way out of obeying Jesus command about loving others. So he asked, “Well, then, who IS my neighbor?”

And Jesus answered by telling a story. (*Invite four volunteers to play the hurt man, the priest, the Levite and the Samaritan, pantomiming actions as you tell the story.*)

Once there was a man who traveled alone on the deserted road from Jerusalem to Jericho. Suddenly, a group of robbers charged into his path! (*Boo!*) They took everything he had—even his clothes! They beat him up badly and left him half-dead by the side of the road!

The man tried to get up, but he couldn’t. He was hurt too badly! In deep despair, the man closed his eyes, thinking he was going to die right there in that deserted place. (*Groan.*)

Soon a priest came walking down the road. Maybe he could help the hurt man. (*Yeah!*) He was probably on his way to Jerusalem to serve in the Temple. As he hurried down the road, he saw the man. The priest could see that the man was breathing but he was barely alive! The priest may have thought, *If he dies while I’m touching him, then I can’t enter the Temple until after sunset. THAT would be a disaster! I DO have my responsibilities to think of!* So the priest quickly made up his mind and moved to the other side of the road. He hurried away toward his important job at the Temple—more important to him than helping a hurt man! (*Boo!*)

In a little while, another man came down the road. This man was a Levite. He was also going to take his turn working at the Temple, perhaps as a worship leader or a teacher. And as he walked, he saw the beaten man lying by the side of the road. He walked a little closer to inspect the crime scene. How awful! This man was barely alive! He was bleeding! Maybe this man could help the hurt man. (*Yeah!*) The Levite looked—but he didn’t stop. Maybe he was afraid of being robbed. Maybe he was late for work. But whatever reason he had, he decided it was more important than helping a bleeding, battered stranger. He hurried on down the road. (*Boo!*)

By now, the hurt man must have been feeling hopeless! The very best kinds of people—priests and Levites—had left him to die in the dust. (*Groan.*) Who would possibly help him now?

But then he heard the hooves of a donkey. A third man was coming down the road. This man was a Samaritan—a person the Jews didn't like very much. Normally, this beaten-up traveler wouldn't even have spoken to a Samaritan!

But the Samaritan wasn't calculating whether or not the man might LIKE him. He wasn't thinking about what other things he had to do or whether or not he would get robbed. No, he saw a hurt, beaten, man who needed help—and he STOPPED and DID something about it! (Yeah!)

The Samaritan got off his donkey and gave the man water to drink, poured a little oil on the wounds and then wrapped them with bandages. The hurt man couldn't walk, so the Samaritan put the beaten man onto his own donkey to carry him to an inn—a place where they could spend the night safely, like a hotel. The Samaritan stayed by the bed of the injured man all night, taking care of him. In fact, the Samaritan paid the innkeeper to take care of the hurt man until he was strong enough to travel again!

Jesus finished His story. He asked the lawyer, "Now, which of these men acted like a neighbor to the man who was robbed and beaten?"

"The one who showed kindness, of course!" answered the lawyer. "Then go and do the same!" Jesus said.

GOD'S WORD & ME

It's easy to be kind to people we like. But Jesus told this story to show that God wants us to love like He loves—in action, not just in words. It's not enough to talk about caring for others; we have to put our words into action! The lawyer's question, "WHO is my neighbor?" wasn't as important as asking, "How can I BE a neighbor?" Anyone who needs our help is our neighbor!



- Invite a child to read 1 John 3:18 aloud. Then invite volunteers to quote John 3:16. **What did God do to show us love?** (He sent Jesus to die for us so we can join His family.) **That's a LOT of love! If God loves us this much, how much love do you think we should show—even to people we don't like?**

- **Who is a person it might be hard to show love or kindness to?** (Bully. Little brother or sister. Cranky neighbor.) **Think of one action you could do to show love to that person.**

- **When it's hard to show love or care, when we don't feel like it, what can we do?** (Ask God. He will make us able to show His love.) Invite children to pray silently and then pray aloud with them, asking God to help them care for others and show His love even when it's not an easy thing to do.

GAME CENTER

FOR YOUNGER CHILDREN • LUKE 10:25-37

COLLECT

Bible, large piece of fabric or beach towel and small ball for each group of four to six children.

DO

1. Children form groups of up to six children and hold edges of fabric or towel. Place ball on fabric or towel.
2. As you slowly say the words of 1 John 3:18, children roll the ball across fabric or towel while trying to keep the ball from rolling off.
3. To challenge children, ask them to gently bounce the ball on the fabric or towel.

TALK ABOUT

- The Bible says, "Love others with actions, not just words." God wants us to show His love to others all the time, even when we're playing a game. How can we show love when we are playing this game today?
- Nathan, you are showing love to your friends by lifting the towel gently. What are some other ways you show love to your friends? How do you show love to a friend when you are playing at your friend's house? (Help clean up. Take turns playing a game.)
- Daniela, who is someone you live with? How can you show love to your mom? In what ways might she need help?
- Thank you for showing love during our game today. Pray briefly, Dear God, thank You for the friends who are here today. Please help us remember to show love to each other. In Jesus' name, amen.

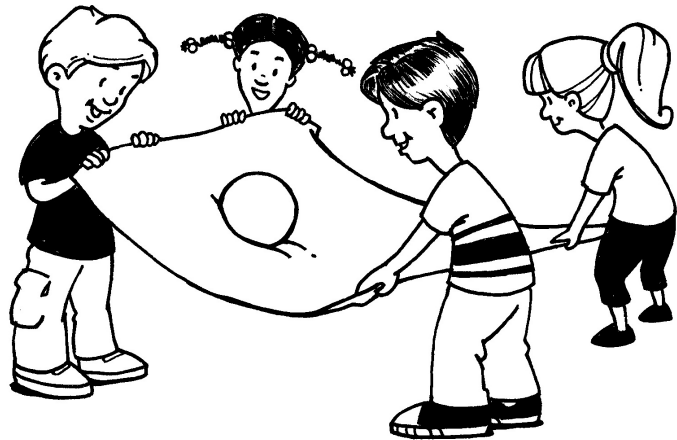

GOD'S WORD

"Let us not love with words or tongue
but with actions and in truth."
1 John 3:18

FOR YOUNGER CHILDREN:

"Love others with actions, not just words."

GOD'S WORD & ME

Showing God's love means we do more
than just talk about caring for others:
we put our words into action.

FOR OLDER CHILDREN

After children form groups, they try to bounce the ball from one group to the next as the words of the verse are being said.

GAME CENTER

FOR OLDER CHILDREN • LUKE 10:25-37

COLLECT

Bible, Lesson 7 Pattern Page (p. 140), scissors, umbrella for each team.

PREPARE

Photocopy Lesson 7 Pattern Page and cut apart to make a set of verse cards for each team.

DO

1. Place each team's set of verse cards at one end of an open room. Set a closed umbrella by each set of cards.
2. Children line up in teams of up to eight players across the room from the cards. Explain to children that in the rainforest the branches and leaves of tall trees form a canopy or covering over the animals that live in the rainforest. **Today in our game we are going to use umbrellas as our rainforest canopy.**
3. To collect their team's verse cards, players take turns running across the room, opening the umbrella, picking up a card, closing the umbrella and then running back to their teams. Teams put verse cards in order. Read verse aloud with all children.

TALK ABOUT

- **How many actions can you think of that would show love and kindness to a friend at school? To someone you live with?** As children tell actions, encourage them to be specific in describing the actions. **These are all good ways to do what 1 John 3:18 talks about—show love for others in actions, not just words.** Read verse aloud.
- **When do you think it might be hardest to show love in action? What advice would you give to a friend who finds it hard to show love and care to others?** (Remember times people have cared for you. Pray and ask God's help. Think of how your actions can affect others.)
- **What are some of the reasons it's good to do what this verse says—not just talk about caring for others, but doing it?** (Others see that following Jesus really makes a difference in how a person acts. Helps people get along. Others show care back to you.)
- **Think of someone who shows love to you and God for that person. Now think of someone you need help in showing love to. Ask God's help.** Pause to allow time for children to pray, and then close the prayer time, thanking God for His love for us and asking His help in passing it on.

FOR YOUNGER CHILDREN

Number the back of the cards in verse order. Open the umbrellas and place the cards under the umbrella. Children take turns walking up to the umbrella, getting a card and bringing it back to their teams. Be available to help children place cards in number order and then turn them over. Read words aloud to children.

GOD'S WORD

"Let us not love with words or tongue
but with actions and in truth."
1 John 3:18

FOR YOUNGER CHILDREN:

"Love others with actions, not just words."

GOD'S WORD & ME

Showing God's love means we do more
than just talk about caring for others:
we put our words into action.



ART CENTER

FOR YOUNGER CHILDREN • LUKE 10:25-37

COLLECT

Bible, large sheet of paper for each child, markers, 2-inch (5-cm) construction paper circles, glue sticks.

PREPARE

Draw a simple house outline and four windows (at least 2 inches [5 cm] in size on the house. Prepare a house outline for each child.

DO

1. Give each child several paper circles. Child draws his or her face and faces of household members on the circles.
2. Give each child a house outline. Child glues faces in the windows and colors house. Children may add trees, flowers, etc. to their house pictures.

TALK ABOUT

- **Every day we can be kind and loving to the people we live with. Who lives in your house? What can you do to show love to your (mom)? What can you do?**
- **The Bible says, “Love others with actions, not just words.” Actions are the things we do. One thing we can do at home is help the people we live with. What can you do to help at home?**
- **Who loves you and helps you? We’re glad when people love and help us.** Lead children in prayer, thanking God for people who love them and asking His help in loving others.

FOR OLDER CHILDREN

Fold large sheets of paper in half to make cards. Children draw pictures of their houses on front of the cards, including windows for the people they live with. Demonstrate to children how to use a scissors to cut out the windows. Keeping cards closed, children draw faces in windows. Children open cards and write names of people pictured and ways they can act to show love to them.



ART CENTER

FOR OLDER CHILDREN • LUKE 10:25-37

COLLECT

Bible, large sheets of paper, a variety of circular shapes in different sizes (margarine tub lid, potato chip can lid, pot lid, jar lid, plate, cookie cutter, etc.), markers (including black).

DO

1. Children trace around a variety of circular shapes to cover paper with at least nine overlapping circles.
2. Children fill in each circle and section with a different repeating pattern (dots, squares, flowers, squiggles, etc.). Encourage children to use a variety of patterns and colors.
3. Printing large, thick letters, children write one letter from the phrase "act in love" in each of nine consecutive sections.

TALK ABOUT

- Read 1 John 3:18 aloud. **What do you think is the hardest thing about doing what this verse says?** (When someone has been mean to you. When you don't know the person very well. When you are tired of being kind to the person.)
- **How can we know good ways to show that we care for others?** (Ask the person how you can help. Read God's Word and know His commands. Follow the examples of others.)
- **What makes it hard for kids sometimes to actually treat others in kind ways, instead of just talking about showing kindness?** (Someone makes them angry. They forget to ask God for help to act in good ways. They feel like it's someone else's turn to be kind.)
- **What might help you continue to show love and care for others, even when you don't feel like it?** (Pray to God and ask His help. Remember how God and others cared for you.) Lead children in prayer, asking God's help to act in loving ways instead of only talking about showing love.

FOR YOUNGER CHILDREN

Children make at least four circles on their papers. After coloring circles, print (or let children print) one letter from the word "love" in each circle.

GOD'S WORD

"Let us not love with words or tongue
but with actions and in truth."
1 John 3:18

FOR YOUNGER CHILDREN:

"Love others with actions, not just words."

GOD'S WORD & ME

Showing God's love means we do more
than just talk about caring for others:
we put our words into action.

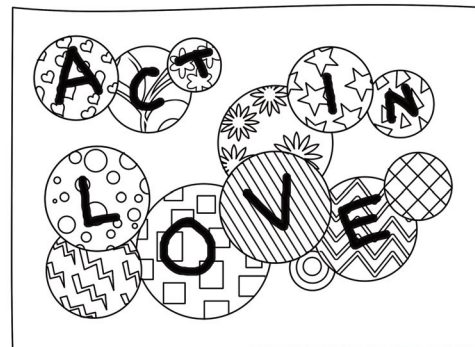

WORSHIP CENTER

Luke 10:25-37

COLLECT

Bibles, *Parable Quest* CD-ROM and CD player, song charts (pp. 246, 252).

TEAM GAME

Explain to children that there are lots of monkeys in the rainforest and that monkeys like to copy each other. Then lead children to play a game like Simon Says, but call it "Monkey See, Monkey Do." Begin the game by doing an action such as clapping hands. Children imitate your action. Periodically change to a new action (patting knees, waving, stomping feet, etc.). Children only do the new action when you call out "Monkey See, Monkey Do." When children make a mistake in the game, let them keep playing.

BIBLE VERSE GAME

Repeat 1 John 3:18 aloud with children. Children stand in a line. Assign a word of the verse to each child in order. Children walk around. At your signal, children quickly form a rainforest vine by placing themselves in verse order with a hand on the shoulder of the person ahead. Children say verse words in order, and then repeat all together. Repeat as time permits, assigning children different verse words or challenging them to see if they can form the vine faster.



GOD'S WORD

"Let us not love with words or tongue
but with actions and in truth."

1 John 3:18

FOR YOUNGER CHILDREN:

"Love others with actions, not just words."

GOD'S WORD & ME

Showing God's love means we do more
than just talk about caring for others:
we put our words into action.

SONG

You, or another leader, lead children in singing "Love Never Fails," adding motions and/or clapping if desired.

PRAYER

Who is someone you know who shows their love and care by their actions—not just their words? As children respond, tell your answer, too. Lead children in prayer, thanking God for the people they mentioned. End prayer by thanking God for His love and asking His help in showing love to others.

SONG

You, or another leader, lead children in singing "Following Jesus," adding motions and/or clapping if desired.

“Let us

not love

with words

or tongue

but with actions

and in

truth.”

1 John 3:18

Jesus tells about a good Samaritan.

Luke 10:25-37



Who can you show love to? What can you do?

a COORDINATED MESSAGE!

Use the letters and numbers (called coordinates) to fill in the blanks below.

A	E	L	X	F	K	d	a	S	k	S
B	U	Z	D	h	e	O	T	G	j	h
C	a	n	Y	b	Y	c	Z	O	M	L
D	M	O	b	X	I	W	a	L	i	Z
E	p	e	P	C	v	R	Q	d	u	t
F	f	R	Y	O	W	X	B	C	V	B
G	G	q	j	M	P	v	g	W	A	D
H	J	E	i	I	g	i	C	q	T	S
I	R	N	n	h	K	E	F	U	k	L
	1	2	3	4	5	6	7	8	9	10

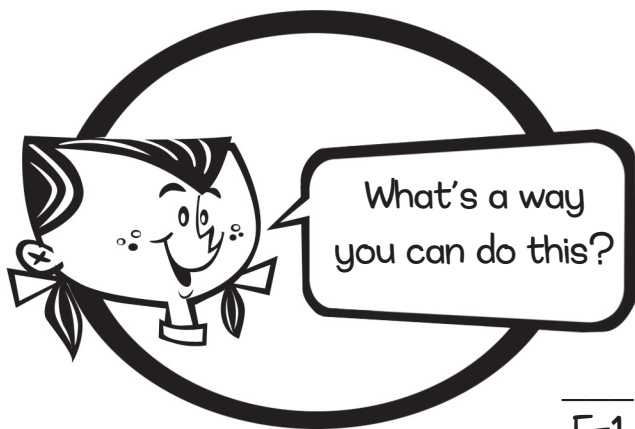

B-3 F-4 C-9 D-2 I-1 E-2

H-9 B-4 D-7 C-2

B-7 G-9 A-2 I-5

E-1 I-8 E-10 C-3 F-4 E-9 E-6

D-6 F-4 F-2 E-8 A-10 H-6 C-2 B-7 F-4

C-1 E-4 H-9 D-5 F-4 C-2 !

PERSISTENT FRIEND

LUKE 11:1-13



**NEVER GIVE
UP PRAYING**

Teacher's Devotional

If the check-out clerk were to ask, "What's the biggest reason you pray?" how would you answer? After all, people in every religion pray. Why do we pray? What makes it any different for a follower of Jesus Christ to pray? Is it that we pray longer? With more words? With more faith? In a different posture? No. All human-effort-based religious methods soon wear us out—then we quit praying altogether!

When we followers of Jesus pray, the difference is not in the amount of faith we have, nor the right words or even lots of words (in Matthew 6, Jesus ridiculed this kind of thing, remember?). The difference is to whom we pray! We aren't sending out a vague wish to some higher power nor a faint hope on the farthest star—no! We are talking directly to the maker of the stars, the omnipotent God of the universe—and our dear Father! This is the reason Jesus' followers were so fascinated with Jesus' kind of prayer: They were used to addressing the Ruler of the Universe in formal religious prayers (in a certain way, at a certain time)—but to think that this mighty King was also their Father? Revolutionary! The very name "Father" spoke of an intimacy in prayer that they had not known before.

This is the reason Jesus told us to keep on asking, keep on seeking, keep on knocking—because when the answer doesn't come right away, it's only because our loving Father is up to something we can't yet see. He is working something beyond our comprehension and bigger than our lives. We pray, confident that He will hear and answer because we know Him—He is good, He wants to hear from us and He has an answer that will surprise and delight! So, pray—expectantly!

GOD'S WORD

"Call upon me and come and pray to me, and I will listen to you."
Jeremiah 29:12

FOR YOUNGER CHILDREN:

"Pray to God and he will hear you."

GOD'S WORD & ME

Never give up praying, because God promises to hear and answer our prayers.

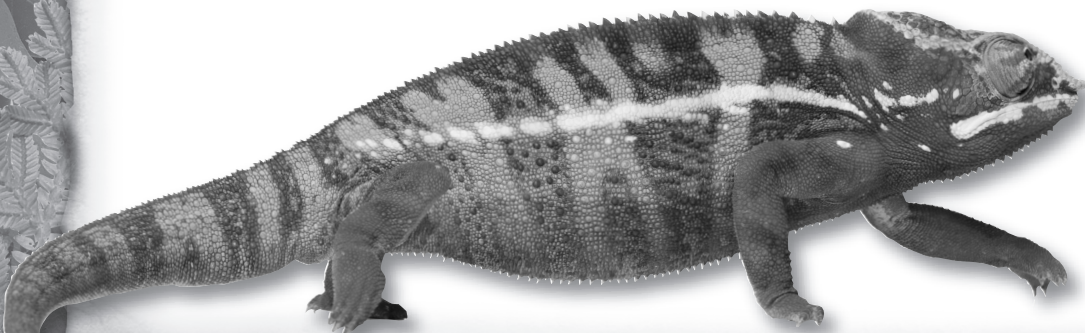

PLANNING PAGE

Choose which centers you will provide and the order in which children will participate in them (see pp. 14-18 for schedule tips and pp. 24-25 for guidelines in combining older and younger children). Also plan who will lead each center (for staffing tips see pp. 19-21). Use the reproducible planning sheet (p. 238) to record your plans.

BIBLE STORY CENTER

BIBLE STORY

Persistent Friend • Luke 11:1-13

ADVENTURE BOX (YOUNGER CHILD)

Use props (blanket or shawl, an unsliced loaf of bread, bread knife and bread board) to demonstrate story action

ADVENTURE BOX (OLDER CHILD)

Use props (blanket or shawl, a flashlight, an unsliced loaf of bread, a bread knife, a bread board, a plastic snake or scorpion) to demonstrate story action

ART CENTER

YOUNGER CHILD OPTION

Make faces in play dough and talk about various times to pray to God

MATERIALS

Bible, play dough

OLDER CHILD OPTION

Make toucan spinners to take home as reminders of praying to Jesus

MATERIALS

Bible, Lesson 8 Pattern Page (p. 154), card stock, scissors, markers, hole punch, thread or fishing wire

GAME CENTER

YOUNGER CHILD OPTION

Practice listening while playing a fun game and then talk about God's promise to listen when we pray

MATERIALS

Bible, construction paper in two colors (one paper for each child)

OLDER CHILD OPTION

Roll paper balls to score points and to talk about places to pray to God and things about which children may pray

MATERIALS

Bible, masking tape, scratch paper in a variety of colors (one color for each team of up to six players)

COLORING/PUZZLE CENTER

YOUNGER CHILD OPTION

Review the Bible story while completing coloring page

MATERIALS

Lesson 8 Coloring Page (p. 155) for each child, crayons

OLDER CHILD OPTION

Review Jeremiah 29:12 while completing puzzle page

MATERIALS

Lesson 8 Puzzle Page (p. 156) for each child, pencils

WORSHIP CENTER

FOR THE YOUNGER AND OLDER CHILD

Participate in large-group activities to review Bible verse and to worship God together

MATERIALS

Bibles, *Parable Quest* CD-ROM and CD player, song charts (pp. 248-249), large sheet of paper on which you have lettered the words of Jeremiah 29:12, small colored candies such as M&Ms® or Skittles® or small squares of colored paper, several small disposable bowls, index cards, pen

BONUS THEME IDEAS

Bonus Theme Ideas can be used at any time during this session: as an additional activity center, to extend the session for a longer time, or for added theme excitement.

FROGGY SNACKS

Ahead of time prepare green Jell-O® in shallow bowls. Make one bowl for each child. Give each child two banana slices to place as eyes and either M&Ms® or raisins for pupils. Child places apple wedge on Jell-O to form mouth. Provide plastic spoons for children to use in eating their Froggy Snacks.

Post a note alerting parents to the use of food. Also, check registration forms for possible food allergies.



RAINFOREST ANIMAL LINEUP

Have children stand in a circle, square or triangle. Assign each child the name of a rainforest animal (toucan, parrot, gecko, pink dolphin, frog, monkey, butterfly, leaf cutter ant, ocelot, jaguar, sloth, etc.). Each child thinks of a sound or action to represent his or her animal. At your signal, children move around the room. When you call "Rainforest Animal Lineup," children race to return to their places and make the appropriate actions and/or sounds. Repeat as time permits, assigning different animals to children.

CREATURE CAMOUFLAGE

Talk with children about how God has made animals with coloring and/or patterns to help them hide in their habitats. Briefly describe the layers of the rainforest: the dark forest floor, the understory with brightly colored flowers, the canopy and emergent layers with green leaves and brown branches. Children draw their own rainforest animal creations and then choose the layer of the rainforest in which their animals will live. Children color their animals to give them camouflage. Display animal creations.



BIBLE STORY CENTER

FOR YOUNGER CHILDREN • LUKE 11:1-13

INTRODUCTION

Welcome your rainforest explorers by inviting them to play a color-finding game: **People wearing red like a strawberry dart frog, hop!** Children respond. **People wearing blue, pretend to be butterflies. Flap your wings!** Continue with other colors and actions (crawl, spin around, etc.), ending with "Sit down" as the action. Then show Adventure Box. **What do you think is in our Adventure Box today? Let's find out!** Untie box. Remove items from box and use them to demonstrate story action as you tell the story and/or lead children in suggested motions.



ADVENTURE BOX

In a cardboard or wooden box labeled "Adventure," place a Bible, a blanket or shawl, an unsliced loaf of bread, bread knife and bread board. Tie rope or brown yarn around the box or crate.

TELL THE STORY

When Jesus lived here on Earth, He helped many, many people! One day, Jesus' friends asked Him to help them learn to pray. So Jesus told a story to help His friends know they should pray and not give up!

Late one night, a man heard a loud knock at his door! He sat up and wondered, *Who could that be?* Then he heard the voice of his old friend! The man opened his door. "Welcome, welcome!" he said. "I'm glad to see you! Let me get a bed ready! Have you eaten?"

"No—and I'm VERY hungry," his friend said. *Oh, no!* thought the man. *I'm out of bread. I don't have food!* He didn't have any bread—but he DID have an idea!

"Dear friend, stay right here! I'll go to ask my neighbor for some bread. He will give me food." He put on his cloak, took his lamp and hurried to his neighbor's house. *(Put blanket or shawl around shoulders.)*

Tap, tap, TAP! He tapped on the neighbor's door. *(Knock on a table or door to illustrate story. Invite children to knock along with you.)* It was quiet. So—knock, knock, KNOCK! He knocked a little louder. This time, he heard his neighbor whisper, "Shh! We're ASLEEP!"

"Please listen, neighbor! My friend came to visit just now. I don't have ANY bread for him. Please lend me some," the man asked. But his neighbor answered, "I can't even get UP. The children are all sleeping around me."

Bang, bang, BANG. The man knocked again, a little louder! He said, "Dear neighbor, my friend is VERY hungry!" The neighbor said, "Look, if I get up, EVERYONE will wake up! The door is locked . . . can't you wait until morning?"

BANG, BANG, BANG! The man knocked a little louder. "No! My friend is hungry NOW!" he said.

The man waited. Would his neighbor help him? Then, the door OPENED! And his neighbor said, "Here! Here's the bread you need." *(Show loaf of bread; cut bread into cubes and invite children to taste.)*

Jesus wanted us to know that when we ask God, He will listen to us. He is glad to help us. God is NEVER too busy or sleepy to answer our prayers. Jesus said that God is like the very best dad EVER. When a boy asks his dad for a fish, his dad gives him a fish, right? A good dad would not give him something that would hurt him, like a snake! Giving his son what he needs is one way a good dad shows love! He is glad to help his son.

GOD'S WORD & ME

The Bible says, "Pray to God and He will hear you." Repeat verse several times together. Then lead children in saying this poem, clapping in rhythm: **God loves to listen when we pray! He'll answer us in the very best way.** Repeat several times. Then pray, **Dear Jesus, thank You for helping us know to pray. Thank You that God listens to us and will answer in the best way. Amen.**



NEVER GIVE
UP PRAYING

BIBLE STORY CENTER

FOR OLDER CHILDREN • LUKE 11:1-13

INTRODUCTION

Let's play a game with our names. Create a sentence in which each word begins with the letters of your first name in order. It doesn't matter if your sentence makes sense. I'll start. My name is Lily: **Like Inventing Little Yo-yos!** Volunteers continue the game; if desired, give small prizes for the funniest or most creative. **Here's a clue to what our story is about today. If I were to say, "Paint Really Awful Yellows," what would the word be?** (Pray.) **That's right!**

What do you think is in our Adventure Box today? Let's find out!

Untie box. Remove items from box and use them to demonstrate story action as you tell the story and/or lead children in suggested motions.



ADVENTURE BOX

In a cardboard or wooden box labeled "Adventure," place a Bible, a blanket or shawl, a flashlight, an unsliced loaf of bread, a bread knife, a bread board, a plastic snake or scorpion. Tie rope or brown yarn around the box or crate.

TELL THE STORY

When Jesus lived here on Earth, there was usually a crowd of people surrounding Him. But when the crowds went home, Jesus spent time praying to God. Praying and talking with God was the way Jesus "charged up" for another day of hard work!

Jesus' friends wanted to learn how to get "charged up" by God like Jesus did. So they asked Jesus, "Lord, teach us to pray!" Jesus was glad to do that! First, He prayed for them a prayer that they could follow. This prayer is now known as "The Lord's Prayer."

Jesus prayed, "Father in heaven, You are holy and good. Help us do Your will here on Earth as it is done in Heaven. Please give us the food and other things that we need. Forgive us our sins. We forgive those who have sinned against us. Please protect us from temptation to do wrong things and help us to do what is right instead."

After praying this prayer, Jesus told this parable about the WAY we should pray.

One night at around midnight, a man heard a loud knock at his door! He sat upright, WIDE awake! *Who could that be?* Then he heard the familiar voice of an old friend! The friend had stopped by to visit, even though it was VERY late! (Remember, in those days people mainly traveled by foot or on a donkey—which meant you didn't always know when you'd get to where you were going!)

Quickly, the man got up and opened his door. "Welcome, welcome!" he probably said. "I'm delighted that you are here! Let me get a bed ready for you! Have you eaten?"

"Well, I've been walking all day long! I'm VERY hungry," his friend said, rubbing his rumbling stomach. *Uh, oh!* thought the man. *I've eaten the last of my bread. I really don't have anything to feed him!* He didn't have any bread—but he DID have an idea!

"Dear friend, I'm so sorry—I'm out of bread! But I'll be right back. I'm going to my neighbor's house. I'm sure they'll give me some bread." He put on his cloak, lifted his oil lamp to light the way and headed out the door toward his neighbor's house. *(Put shawl or blanket around shoulders; pick up flashlight.)*

Tap, tap, TAP! He tapped on the neighbor's door. *(Tap on doorframe or table to illustrate story action.)* It was silent. There was no voice, no answer.

Knock, knock, KNOCK! He knocked louder. This time, he heard his neighbor quietly mutter, "Go AWAY. We're ASLEEP!"

"No! Please listen, neighbor! My friend has come to visit and I don't have ANY food to give him. Please, lend me some!" the man pleaded.

"I can't even get UP for all the sleeping children around me. Can't you come back in the morning?"

Bang, bang, BANG. The man knocked again, a little more determined! He called a little louder. "Neighbor, dear friend, I can't leave until you give me something. I know it's late but my friend is so VERY hungry!"

The neighbor whispered loudly from inside, “Look, we are all in bed. If I get up, EVERYONE will get up! I’ll give you something in the morning, I promise!”

BANG, BANG, BANG! “But my friend is hungry NOW!” the man persisted. “I can’t wait until morning.”

As the man lifted his hand to knock and ask one more time, the door suddenly OPENED! There was his neighbor! In his hand was the bread the man had asked for! “Here!” he said. “Here’s some bread.” (*Show loaf of bread. Cut up bread into chunks as you talk; invite children to sample bread.*)

Jesus wanted His disciples and everyone to know that when we ask Him, God is much MORE willing to help us than that sleepy, grumpy neighbor was!

But Jesus wasn’t finished! He said, “Ask and it will be given to you. Keep on looking. Keep on knocking—because God is a loving Father. He will answer. He wants to help His children!”

Jesus went on, “Some of you here are fathers yourselves. If one of your children asked you for a fish, would you hand him a SNAKE instead? Of course not!” (*Show snake or scorpion.*)

“If your child asked for an egg, would you give him a scorpion? No father would give a scorpion to a child who asked for an egg! That would be CRUEL! You fathers understand that giving a good thing when your child asks is a way you show love! Now, think about this! How much more will your heavenly Father give good things to YOU when you ask Him? He loves you more than the very best father on Earth!”

GOD’S WORD & ME

Jesus wants all of us to know that we can trust God. He is a good Father and He wants to hear from us. God loves us and will help us when we ask Him! Sometimes God answers our prayers with a yes, or a no, or maybe He wants us to wait for the answer. Even when we don’t understand God’s answer, however, we know that He wants what is best for us and will answer in the best way possible for us.

- **When is it hard to remember to pray?** (When hurt. When surprised or scared. When in a strange place.)
- Invite a child to read Jeremiah 29:12 aloud. **What does God promise us?** (He will listen.) **What are some ways to remind ourselves to pray?**
- **Take a moment to choose one of those ways to remember. Let’s ask God to help us remind ourselves to pray in that way.** Pray with children, asking to help them remember to pray and keep on praying.



**NEVER GIVE
UP PRAYING**

GAME CENTER

FOR YOUNGER CHILDREN • LUKE 11:1-13

COLLECT

Bible, construction paper in two colors (one paper for each child); optional—*Parable Quest* CD-ROM and player.

DO

1. Set out sheets of paper in a circle on the floor, alternating the colors.
2. Children stand in a circle around the papers. As children walk around the circle, clap your hands. (Optional: Play “Call Upon Me” from CD-ROM.) After 10 to 15 claps, stop clapping and call out “hands.” Children place their hands on paper nearest to them.
3. Repeat as time and interest permit, calling out other body parts—knee, elbow, ear, foot, etc. You may also vary the game by naming a color before naming the body part. Only the child standing by the named color places his or her body part on the paper.

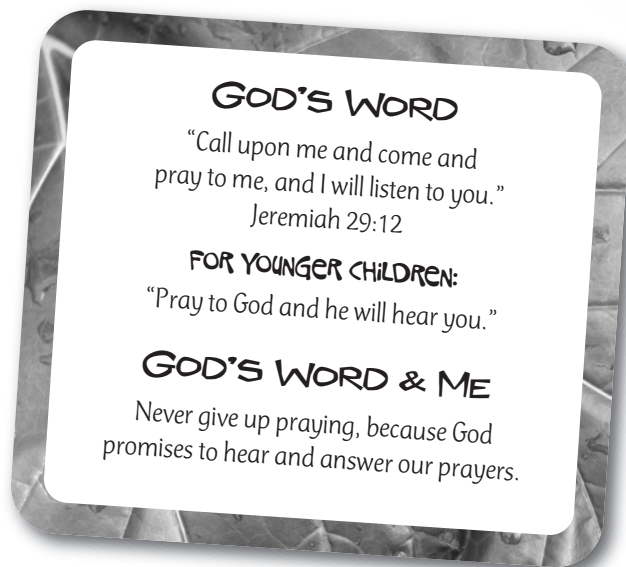

TALK ABOUT

• **In our game today, you listened to what I said. You were good listeners. The Bible tells us that God listens to us: “Pray to God and He will hear you.” God hears us when we talk to Him. What are some times we can talk to God?** (Before dinner. At bedtime.)

• **Sometimes when we pray, we thank Him. What are some things you can thank God for?** (My friends. My pet dog. My toys.)

• **Sometimes when we pray, we ask God for help to do good things. Tell children what you have asked God to do. What is something you would like to ask God to help you do?** (Take turns. Be kind to my brother. Help my mom.) Pray briefly, Dear God, thank You for listening to us when we pray. Please help us to do good things. In Jesus' name, amen.

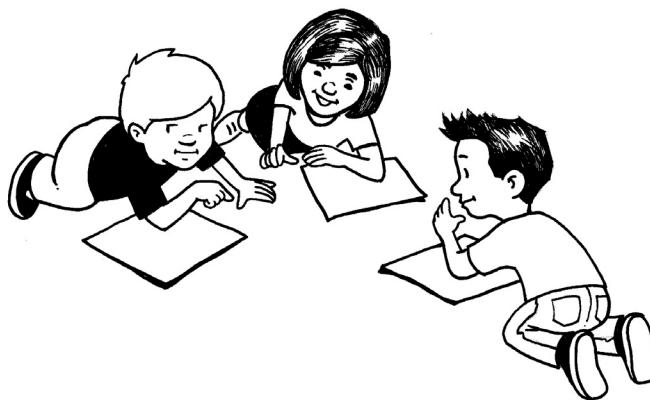

FOR OLDER CHILDREN

Provide a marker by each paper. Play music as children walk around the circle of papers. Stop the music after 10 to 12 seconds. Each child writes his or her answer to the question, “What can you thank God for?” Repeat activity. After several rounds, ask a different question such as “What can you ask God for?” or “Who needs God's help?”

GAME CENTER

FOR OLDER CHILDREN • LUKE 11:1-13

COLLECT

Bible, masking tape, scratch paper in a variety of colors (one color for each team of up to six players); optional—sidewalk chalk.

PREPARE

Make a masking tape X at one end of an open playing area. (Optional: Draw X outdoors on playground.)

DO

1. Help children form teams of up to six players each. Give each team one color of scratch paper to tightly crumple and form into paper balls—one ball for each player.
2. Teams line up in playing area on opposite end of where the X was formed. First player on each team takes a turn to roll his or her paper ball toward the X. Player whose ball ends up closest to the X scores 10 points for his or her team. Next player scores 5. All other players score 1 point each. Be available to help teams keep score records.
3. Repeat until each player has had a turn, or as time permits. Teams total their points. Team with the most points tells places where they can pray to God. Team with the fewest points tells things for which they can thank God. Other teams tell reasons it is good to pray to God.

TALK ABOUT

• Read Jeremiah 29:12 aloud. **What does this verse help us learn about God? About praying to God?** (God wants us to pray to Him. He promises to listen to our prayers.) **God promises to answer our prayers in the best way possible.**

• **Why do some people forget to pray to God?** (They are too busy to take the time. They don't know God will really hear and answer.)

• **How many reasons can you think of for praying to God? When are some times when kids would benefit by praying to God?** (When they are worried about something. When they need help to obey the Bible. When they don't know the best choice to make.)

• Tell children when you pray to God (before bed, in the morning, etc.) and invite children to tell when they can pray to God. Lead children in prayer, asking God's help in remembering to pray to Him and thanking Him for always hearing our prayers.

FOR YOUNGER CHILDREN

Instead of recording points, lead children to repeat the words of the Bible verse before rolling their balls toward the X. During later rounds of the game, children may tell people, pets, foods, etc. for which they want to thank God.

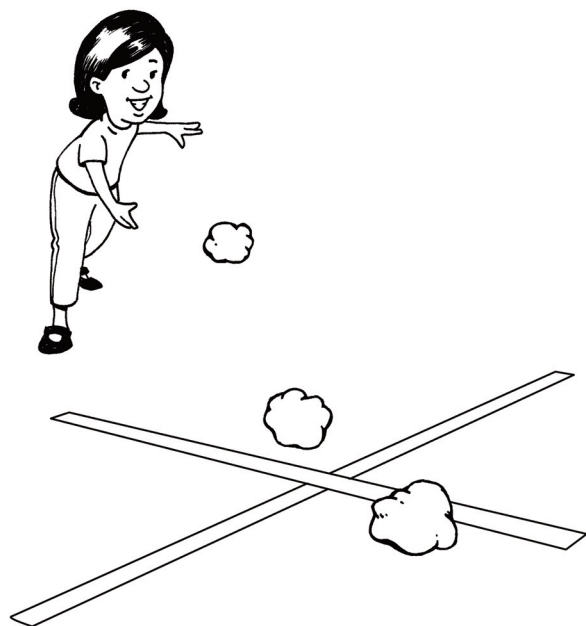
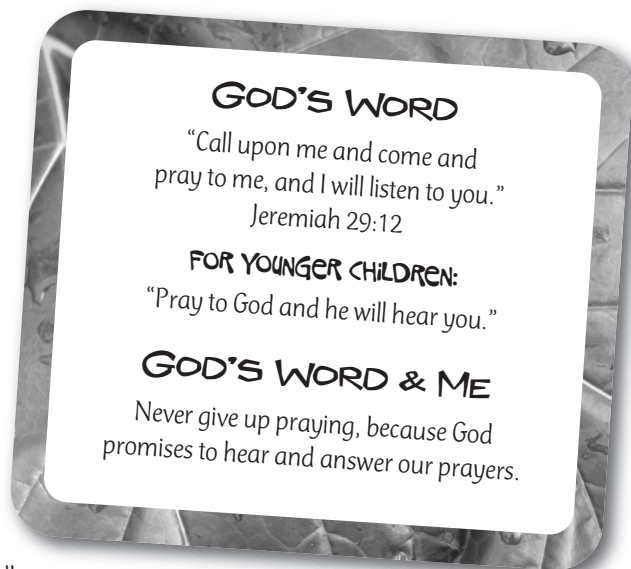

ART CENTER

FOR YOUNGER CHILDREN • LUKE 11:1-13

COLLECT

Bible, play dough; optional—play dough toys and rollers.

DO

1. Give each child a fist-sized lump of play dough. Children play with dough.
2. Form your dough into a flat circle and mark a simple happy face in the dough. Talk with children about things that make them happy for which they can pray and thank God. Invite children to make happy faces with their dough, too.
3. Continue making other facial expressions with your dough (sad, worried, scared, angry) and talking with children about times to pray to God.

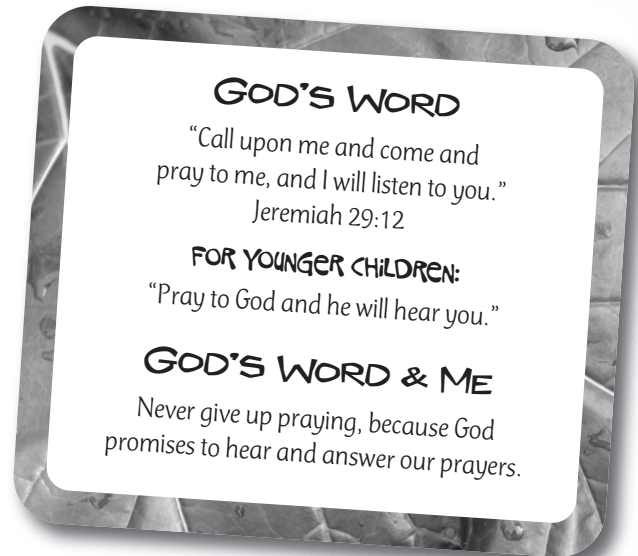

TALK ABOUT

• Look at the happy face I made in my dough. When I am with my family, I am happy. I like to pray and thank God for my family. What makes you happy? What do you want to thank God for?

• Sometimes we might feel sad. Look at the sad face I made in my dough. When I feel sick, I am sad. I ask God to help me feel better. What makes you feel sad? (When I fall down. When someone is mean to me.) **God listens to you when you pray.**

• The Bible says, "Pray to God and He will hear you." No matter where we go or what happens we can talk to God. We can tell Him how we feel and ask His help. God says He will always listen to our prayers. Lead children in a brief prayer time, inviting them to pray to God and thank Him or ask His help.

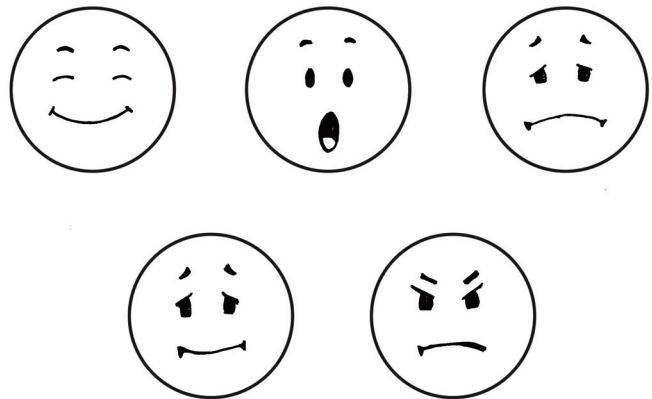

FOR OLDER CHILDREN

Children use dough or air-drying modeling clay to form scenes that portray times kids their age can pray to God (child who needs help to do his or her best while playing soccer, child who needs help to play fairly with a friend, child who wants to thank God while playing at the beach, etc.).

ART CENTER

FOR OLDER CHILDREN • LUKE 11:1-13

COLLECT

Bible, Lesson 8 Pattern Page (p. 154), card stock, scissors, markers, hole punch, thread or fishing wire.

PREPARE

Photocopy Lesson 8 Pattern Page onto card stock, making one page for each child. Make a sample spinner following directions below.

DO

1. Give each child a Lesson 8 Pattern Page. Children color the circle and animal and then cut them out.
2. Children punch hole in circle and in top of toucan circle as marked.
3. Be ready to help children insert a loop of thread or fishing wire through both holes and tie so that toucan circle spins. Children insert a second thread or fishing wire through the hole in the circle and use to hang their spinners at home.

TALK ABOUT

- Read Jeremiah 29:12 aloud. **Why do you think God wants us to pray to Him?** (He loves us and wants to help us. He wants us to remember to depend on Him.)
- **How might it help a kid your age to talk to God first thing every morning? At night before bedtime? Before a meal? What are some other times it's good to talk to God?**
- **What is something you and your family have prayed about? How has God answered your prayer?** Children respond. **Sometimes it might seem like God doesn't hear our prayers because He doesn't answer the way we want Him to. But we can know that because God loves us so much, He always wants what is best for us. God will answers our prayers in the very best way.** Lead children in a brief prayer, thanking God for always hearing and answering our prayers.

FOR YOUNGER CHILDREN

Use a photocopier to enlarge the toucan circle on Lesson 8 Pattern Page. Cut out the circle ahead of time. Children color shape, punch hole in top and insert thread or fishing wire. Tie thread or wire to make a hanger.

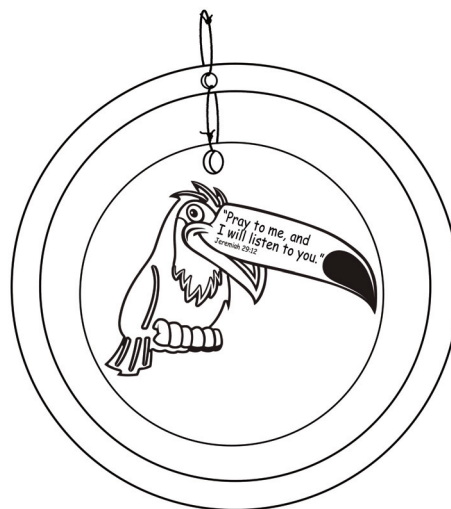
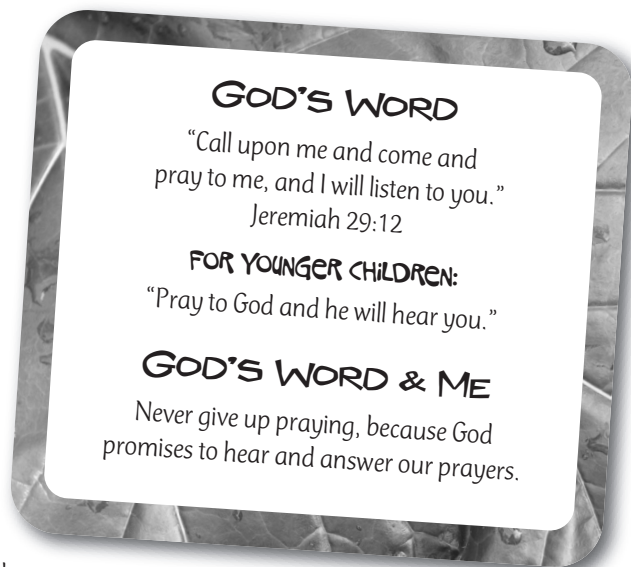

WORSHIP CENTER

Luke 11:1-13

COLLECT

Bibles, *Parable Quest* CD-ROM and CD player, song charts (pp. 248-249), large sheet of paper on which you have lettered the words of Jeremiah 29:12, small colored candies such as M&Ms® or Skittles® or small squares of colored paper, several small disposable bowls, index cards, pen.

PREPARATION

Put candies or papers in bowls.

TEAM GAME

Pass bowls around the room with each child taking two pieces of candy or two papers. After all children have two candies or papers, announce that all children with (red) candy or paper need to jump up and shout out their favorite food. Repeat with other colors and shout outs (favorite sport, favorite game, favorite TV show, etc.).

BIBLE VERSE GAME

Display the paper on which you have lettered the words of Jeremiah 29:12. Read verse aloud with children. Then lead children to play a game like Charades. Ask children to guess which word is represented by this motion: point to yourself. Repeat motion until children guess the word "me." Then invite children to create and show motions for additional words in the verse (hands to mouth for "call," point to someone for "you," beckon for "come," folded hands for "pray," hand behind ear for "listen").

SONG

You, or another leader, lead children in singing "Call Upon Me," adding motions and/or clapping if desired.

PRAYER

Invite children to suggest prayer requests for themselves or others. As each request is mentioned, write it on an index card. Give index cards to children who will pray for these requests at home. Lead children in prayer, mentioning the requests.

SONG

You, or another leader, lead children in singing "All of the Time," adding motions and/or clapping if desired.

GOD'S WORD

"Call upon me and come and pray to me, and I will listen to you."
Jeremiah 29:12

FOR YOUNGER CHILDREN:

"Pray to God and he will hear you."

GOD'S WORD & ME

Never give up praying, because God promises to hear and answer our prayers.

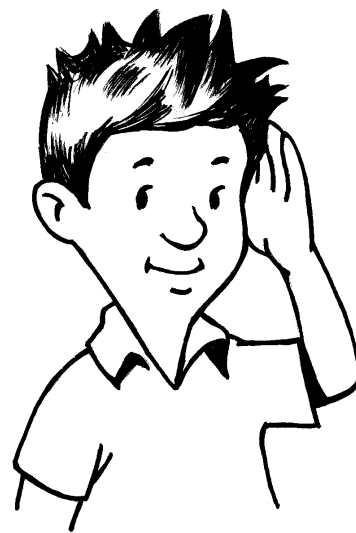

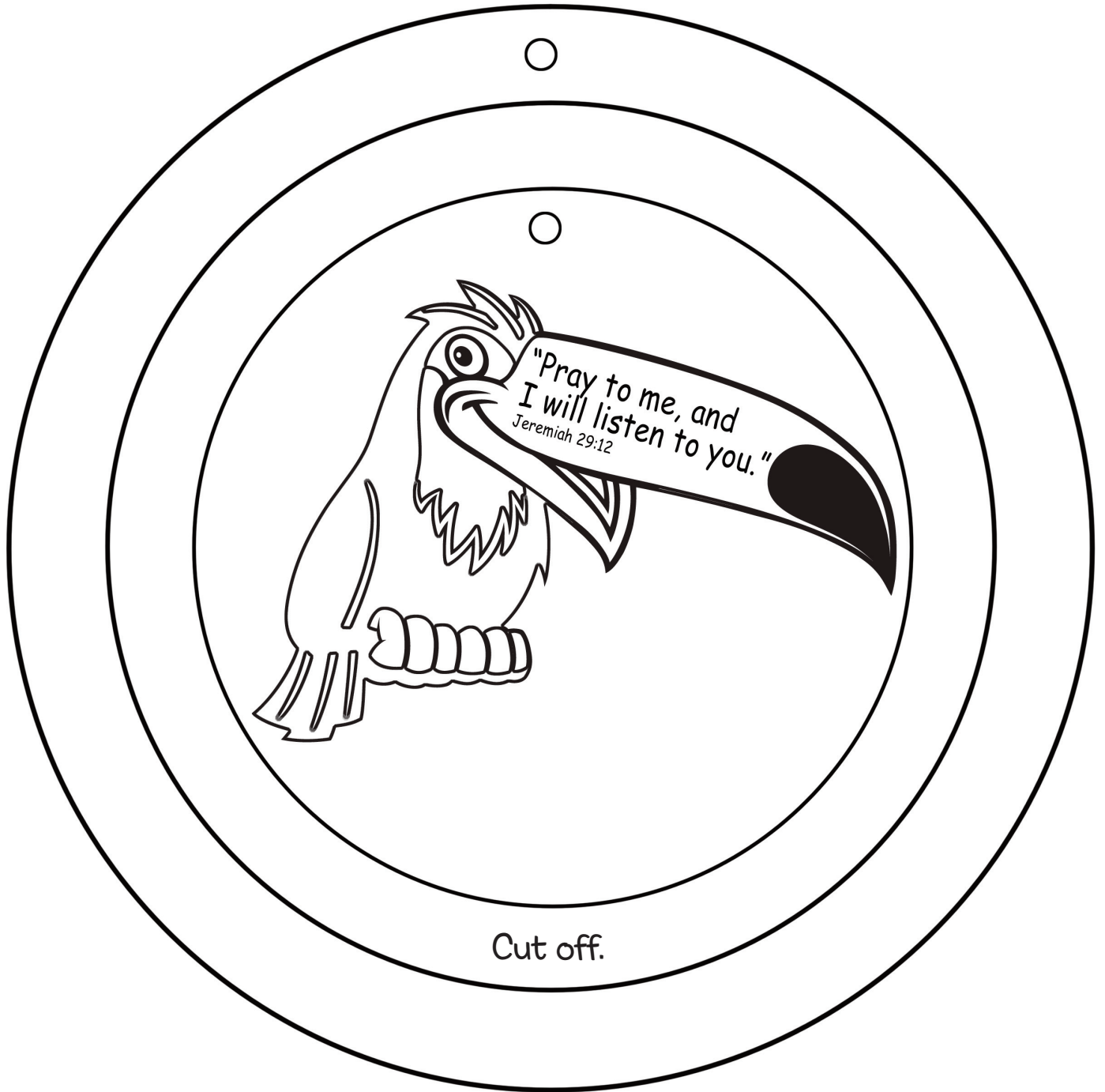

Jesus' friends learn to pray.
Luke 11:1-3



When can you pray to God?

Make a MOUNTAINOUS EFFORT!

Crack the code to discover what these mountain climbers (and you) should keep on doing! Cross out the Qs, Xs and Zs. Then read your way across the mountains. Write the letters in order below, and divide them into words.

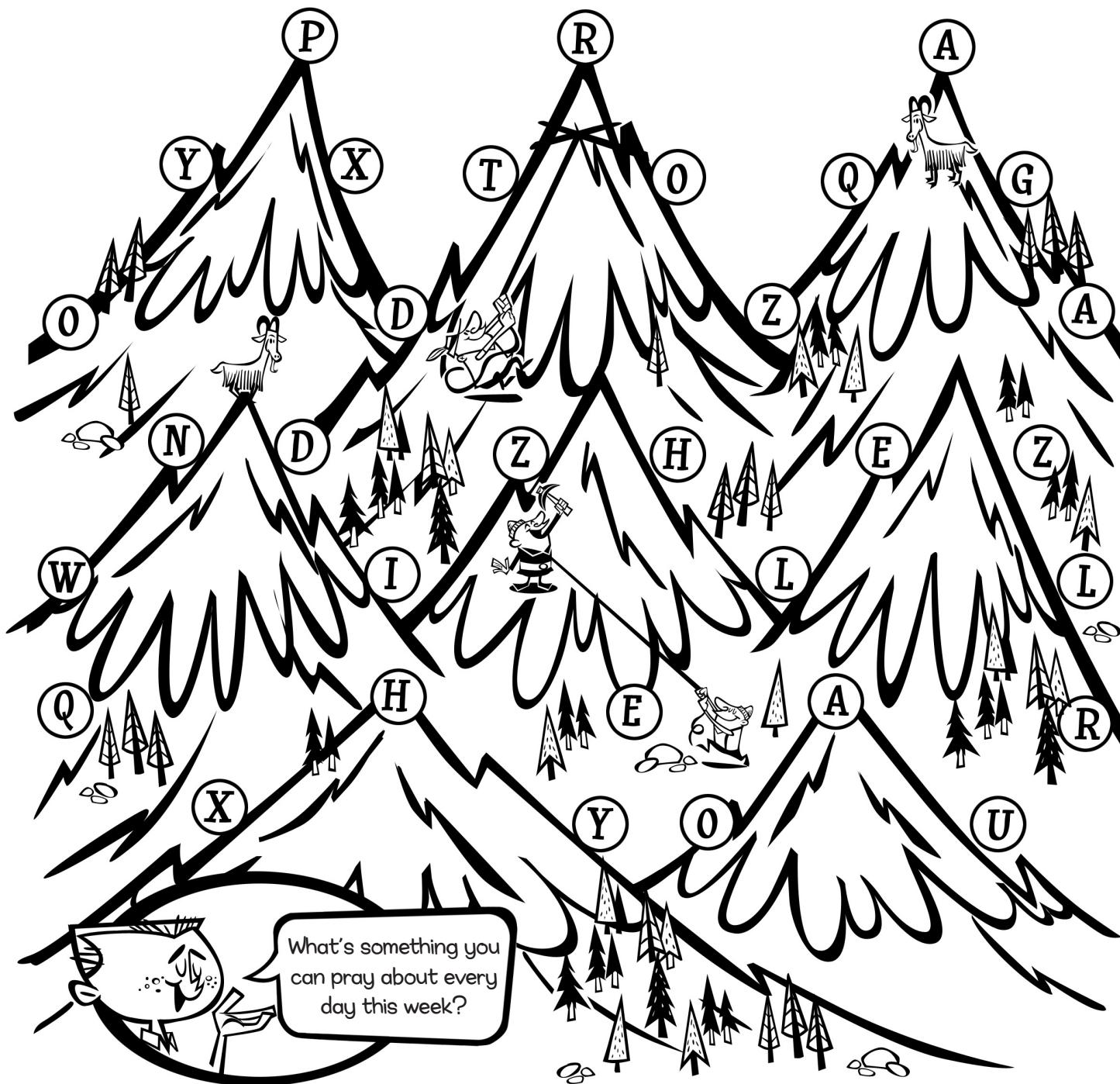

“ _____ ”

RICH FOOL

LUKE 12:13-21



GET TO
KNOW GOD

Teacher's Devotional

What things make a person successful in the eyes of our culture? Fame? Beauty? Wealth? Intelligence? A full schedule? In a recent interview, a handsome, successful, intelligent, wealthy young actor freely admitted that he had no idea what he was doing; he said that his fame made him more insecure and that his wealth left him feeling empty. He had great insight—though he had no solutions to his problems, he could certainly define them!

Would we be as insightful? It's easy for us to think that we need to gain success by having more stuff, more social connections or more entertainment. We are desperately seeking to fill that God-shaped void inside us. Like the man in Jesus' story, we can think that even more places to store our stuff will improve our lives. Yet we all know this is not true!

The biblical message for the young man and for ourselves is that nothing here ultimately satisfies us outside of Christ Himself. We were not made for this world but for another world. The good news is that Jesus has made Himself known. He longs for us to know the Father intimately! Seeking God is not some esoteric spiritual experience reserved for a few: It is the normal course of events for a person passionately in love! As we look expectantly for His hand in events, as we pay attention to His Word for direction and spend more time alone with Him, the constant chatter of our world fades; we become more and more able to hear His still, small voice and to know the truly satisfying nature of seeking and abiding in Him.

GOD'S WORD

"I seek you with all my heart; do not let me stray from your commands."

Psalm 119:10

FOR YOUNGER CHILDREN:

"I love you with all my heart.
Help me obey you."

GOD'S WORD & ME

When we love God more than anything,
we spend our time getting to know Him.



PLANNING PAGE

Choose which centers you will provide and the order in which children will participate in them (see pp. 14-18 for schedule tips and pp. 24-25 for guidelines in combining older and younger children). Also plan who will lead each center (for staffing tips see pp. 19-21). Use the reproducible planning sheet (p. 238) to record your plans.

BIBLE STORY CENTER

BIBLE STORY

Rich Fool • Luke 12:13-21

ADVENTURE BOX (YOUNGER CHILD)

Use props (resealable bag containing grain [rice, oats or wheat], a child's toy barn [or blocks you can use to build a small barn] and a toy person representing a farmer) to demonstrate story action

ADVENTURE BOX (OLDER CHILD)

Use props (resealable bag containing grain [rice, oats or wheat] and a set of interlocking blocks) to demonstrate story action

GAME CENTER

YOUNGER CHILD OPTION

Play a game to build a barn and talk about showing our love for God by thanking Him for good things

MATERIALS

Bible, masking tape, cardboard or wooden blocks

OLDER CHILD OPTION

Play a game like Freeze Tag, repeating Psalm 119:110 when tagged, and then talk about ways kids show they want to love and obey God

MATERIALS

Bible

ART CENTER

YOUNGER CHILD OPTION

Make craft-stick frames with pictures that tell of love for God

MATERIALS

Bible, Lesson 9 Pattern Page (p. 168), four craft sticks, card stock, markers, glue, 18-inch (45.5-cm) lengths of yarn

OLDER CHILD OPTION

Make magnetic phrases about the importance of getting to know God

MATERIALS

Bible, 1½x2-inch (3.8x5-cm) pieces of colored construction paper, thin-tip markers or pens, scissors, ½-inch (1.3-cm) magnetic tape, envelopes

COLORING/PUZZLE CENTER

YOUNGER CHILD OPTION

Review the Bible story while completing coloring page

MATERIALS

Lesson 9 Coloring Page (p. 169) for each child, crayons

OLDER CHILD OPTION

Review Psalm 119:10 while completing puzzle page

MATERIALS

Lesson 9 Puzzle Page (p. 170) for each child, pencils

WORSHIP CENTER

FOR THE YOUNGER AND OLDER CHILD

Participate in large-group activities to review Bible verse and to worship God together

MATERIALS

Bibles, *Parable Quest* CD-ROM and CD player, song charts (pp. 246, 254), plastic banana

BONUS THEME IDEAS

Bonus Theme Ideas can be used at any time during this session: as an additional activity center, to extend the session for a longer time, or for added theme excitement.

COLORFUL SNACKS

Serve one or more of these colorful snacks to remind your children of the brilliant colors in the rainforest: colored fish crackers, rainbow sherbet or Rainbow Vanilla Wafers®.

Post a note alerting parents to the use of food. Also, check registration forms for possible food allergies.



RAINFOREST BUG GAME

In advance, purchase a variety of small toy plastic bugs. (Optional: Make copies of bugs from p. 237.) Form even teams of two to six children. Give each team a container or bag. Scatter bugs around the floor of the room (or around an outdoor playground). Slowly count aloud to 30 or use the clock to see which team can gather the most bugs and put them in their container or bag. To increase the challenge, add a rule that each player can only pick up or hold one bug at a time. (Optional: For greater challenge, children remove socks and shoes and pick up bugs with toes.) Repeat as time permits.

HUMMINGBIRD FLAP

Explain to children that hummingbirds are one of the birds that live in the rainforest and that these birds can flap their wings more than 2,400 times in a minute. Then challenge children to see how many times they can flap their arms in 60 seconds. Use a clock or watch with secondhand to help children keep time.

BIBLE STORY CENTER

FOR YOUNGER CHILDREN • LUKE 12:13-21

INTRODUCTION

Welcome your rainforest explorers by saying **Today, let's all pretend to be rainforest explorers.** Lead children on an imaginary walk, stepping over logs, marching down paths, stomping in water, tiptoeing past snakes, etc. Then show Adventure Box. **What do you think is in our Adventure Box today? Let's find out!** Untie box. Remove items from box and use them to demonstrate story action as you tell the story and/or lead children in suggested motions.



ADVENTURE BOX

In a cardboard or wooden box labeled "Adventure," place a Bible, a resealable bag containing grain (rice, oats or wheat), a child's toy barn (or blocks you can use to build a small barn) and a toy person representing a farmer. Tie rope or brown yarn around the box or crate.

TELL THE STORY

One day Jesus was teaching a big crowd of people. In that crowd was a man who wanted his brother to give him some money. The man even wanted Jesus to tell his brother to give him the money.

Jesus knew that this man was greedy. When you're greedy, it means you think money is more important than anything else in the world! But Jesus wanted the man and the rest of the people in the crowd to know that money and things are not more important than God. So Jesus told them a story.

"There was a farmer who had planted grain. (*Pretend to scatter seeds.*) Now, his fields had grown a lot of grain. In fact, the farmer had so much extra grain that his barns could not hold any more. They were FULL! (*Make a big circle with your arms.*) So he decided to tear down his barns and build bigger barns.

"The farmer was so happy about all the money he would have! The farmer thought he would have so much money he would not have to work anymore. He decided he would just eat and drink and have fun! The farmer thought he would always have enough money! (*Make a happy face.*)

"But God knew the farmer's life would end soon. God said to him, 'You fool! You will die tonight. Then who will get all your money?'"

Jesus wanted the crowd to know why the farmer was foolish. The farmer thought ONLY about his money! He didn't thank God for all the good things he had. (*Shake head no.*) He didn't use his money to help anyone else. (*Shake head no.*)

Jesus told this story so that the people listening would all learn that knowing and loving God is more important than having lots of money.

GOD'S WORD & ME

God wants us to remember that knowing and loving Him is the very best thing of all! Having money is not wrong or bad, but loving and obeying God is what makes us truly glad. In the Bible, we can read a verse that says "I love you with all my heart. Help me obey you." These words are like a prayer to God. Let's say these words together as our prayer. Lead children to repeat this verse as a prayer.



NEVER GIVE
UP PRAYING

BIBLE STORY CENTER

FOR OLDER CHILDREN • LUKE 12:16-21

INTRODUCTION

Let's play an add-on game. The category is, "What's in my garage?" Each of you must remember the list and add one item of your own. Start by saying, **In my garage I have a (bike).** Children name items, each adding one item to the list. To play a second round, let the person who forgets an item from the list begin a new list. Then say, **Today's story is about a man whose barn—kind of like our garages—was full! Listen to hear what Jesus said about the man.**

What do you think is in our Adventure Box today? Let's find out! Untie box. Remove items from box and use them to demonstrate story action as you tell the story.

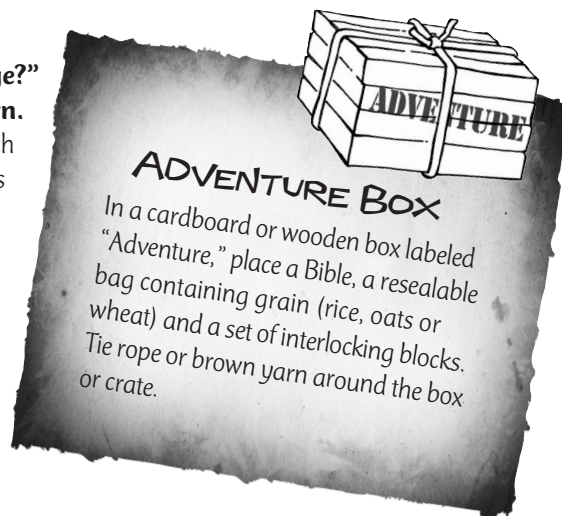

TELL THE STORY

Jesus was speaking to His disciples and many people had gathered to listen. But a young man was determined to get to Jesus. He pushed his way through the crowd.

When the young man finally reached Jesus, he blurted out his problem. "Teacher, my father died recently. He left all his money and possessions to my brother and me. But I can't get my brother to give me my fair share. Tell him to give me half, right now!"

Jesus turned to the man. "Who appointed Me to settle a fight between you and your brother? I'm not here to settle arguments!" Now, Jesus DID care about the young man's problem. BUT Jesus knew more about this man than the man knew about himself. Jesus knew that both brothers were suffering from a kind of disease—greed. Greed means always wanting more and more things, even if you don't NEED those things. Greed makes people who already have lots of things want MORE—even if it hurts other people to get what they want.

Jesus looked around at the people listening. He warned, "Watch out for greed—it comes in many forms. A person's life is not measured by the many things he owns." Jesus wanted people to know that money and possessions are NOT the most important things in life!

Then Jesus began to tell a story about a rich farmer. This is the story He told:

There was a farmer who was so successful that his fields produced many baskets of grain. He had so MUCH grain that his barn was full—it couldn't hold one more basket of grain! (*Show bag of grain; invite children to pass it around. Begin to build a building with interlocking blocks as you speak.*) The farmer thought about his problem. "I know what I'll do," the farmer decided. "Since I'm growing such good crops, I am going to need more space for them. I'll tear down the barn I have now. Then I'll build new barns that are MUCH bigger and MUCH better!" (*Tear down the building you have built and begin to build a larger one.*)

The more he thought about his building project, the more excited the farmer became. He even lay in bed at night and dreamed about all of his riches and the ways he was going to spend his money.

I'm going to take life easy from here on, the farmer thought. I'll eat and drink all I want and just have FUN! I won't worry about anyone or anything!

But God said to him, "You FOOL! This very night, you are going to die! Then who will get those things you have stored away for yourself?" (*Remove building you built.*)

The rich farmer had no interest in thanking God for all the good things God had given him. He didn't think at ALL about sharing his wealth with others who were poor or needed his help. The only thing he thought about was how to keep everything for HIMSELF!

Then Jesus said, "This is how it will be for anyone who stores up things for himself but does not grow rich toward God." The people listening must have wondered what THAT meant! But being rich toward God isn't all that hard to figure out. It means loving Him first and most!

GOD'S WORD & ME

Loving Him first means that we spend time getting to know Him. Then we trust Him to take care of us! Sometimes it seems like everyone else in the world is greedy and everyone says it is OK to be that way. Jesus' story helps us realize that even being rich and having everything you want does not guarantee you will be happy. Jesus wants us to think about what is really the most important thing in our lives!



**NEVER GIVE
UP PRAYING**

- **Why do you think Jesus told the story of the rich man?** (To teach people that God should be most important in their lives.)
- Invite a child to read aloud Psalm 119:10. **What do you think it means to seek God with all your heart?** (To spend time with God, to listen to and think about His Word. To show we love Him more than anything.) **When is a time you could plan to seek God?**
- **What is one thing a kid your age really wants to have?** (The newest phone, game, iPod, etc.) **What kinds of things do people do to get these things? Why might getting a cool new (game) not make a kid happy?**
- **Think of something you really want. Did you know that you could pray about that? Let's ask God to help us love Him first and then invite Him to give us the things we should have.** Pray with children, asking God to help them put Him first and then trust Him to give them the good things they need.



GAME CENTER

FOR YOUNGER CHILDREN • LUKE 12:13-21

COLLECT

Bible, masking tape, cardboard or wooden blocks.

PREPARE

Use masking tape to make a large square on the floor at one end of an open area in your classroom. Stack blocks at the other end of the open area. Make one game setup for each group of up to six children.

DO

1. Help children form teams of up to six children each. Teams line up between the stack of blocks and the masking-tape square.
2. On each team, the player closest to the stack of blocks picks up one block and passes it to the next child in line. Children continue to pass block in this manner until it reaches the end of the line. Last child in line sets block on masking tape to begin building a barn. Repeat with additional blocks. Let children take turns being first or last in the line.
3. For additional rounds, add more challenge by having children pass blocks between their legs, or alternate passing block between legs and over heads. (Call out "over" and "under" to guide the passing.)

TALK ABOUT

- In our Bible story today, Jesus told about a man who decided to build some barns. The man was so busy building barns that he forgot to love and obey God! He forgot to thank God for the good things He had.
- What are some things we can thank God for at our church? (Our friends. The snack we eat.) What are some things we can thank God for at home? (Our moms and dads. Our toys. Our pets.)
- No matter where we go we can remember God's love for us. We can remember to show that we love God and obey Him. Taking turns with our friends is a way to love and obey God. When can you take turns with your friends? (While we play games. When we choose snacks.)
- Pray briefly, Dear God, thank You for loving us. We want to love and obey You. Thank You for all the good things You give us. In Jesus' name, amen.

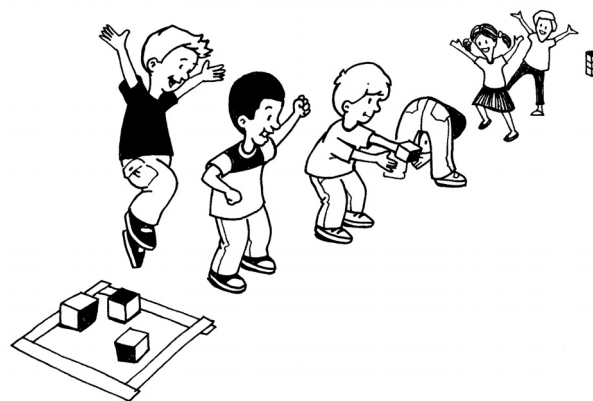

GOD'S WORD

"I seek you with all my heart; do not let me stray from your commands."
Psalm 119:10

FOR YOUNGER CHILDREN:

"I love you with all my heart.
Help me obey you."

GOD'S WORD & ME

When we love God more than anything,
we spend our time getting to know Him.

FOR OLDER CHILDREN

Do not place masking tape on floor. Children build barn in the shape of their own choosing. As blocks are added to the barn, children say the words of Psalm 119:10 in order.

GAME CENTER

FOR OLDER CHILDREN • LUKE 12:13-21

COLLECT

Bible.

DO

1. Lead children to play a game like Freeze Tag. Tell children a way to move (heel-to-toe, tiptoe, baby steps, hop, walk backwards, etc.). Choose one or two children to be "It."
2. At your signal, "It" begins to chase other children with everyone moving in the designated manner. When a child is tagged, he or she must say the words of Psalm 119:10 before joining in the game again. (Optional: Children say a phrase from the verse instead of the whole verse.)
3. Continue playing until every child has had a turn to be "It." For each round, vary the way in which children move.

TALK ABOUT

- Read Psalm 119:110 aloud. **How might kids your age act if they are seeking God?** (Act in ways that show their love for God and others. Show compassion to others.) **How might kids your age spend their time?** (Read and remember verses from the Bible. Sing songs that thank and praise God.)
- **What might make people forget to thank God for the good things He gives?** (They think getting money or toys are more important than following God. They think they deserve the good things they have or the good things that happen to them.)
- **Sometimes it can be easy to forget about God when we're not at church. What can you do to remember how important it is to spend time getting to know God?** (Play Christian music. Plan to read the Bible every night before bed. Pray and ask God's help.)
- **Think about one way you want to get to know God.** Tell children one way you spend time getting to know God. Then lead children in prayer, thanking God for His love and care and asking His help in loving and obeying Him.

FOR YOUNGER CHILDREN

Instead of having children be "It," have adults be "It" and try to tag children. When tagged, children call out sentences such as "I can listen to God's Word" or "I can pray to God" or "I can sing to God."

GOD'S WORD

"I seek you with all my heart; do not let me stray from your commands."
Psalm 119:10

FOR YOUNGER CHILDREN:

"I love you with all my heart.
Help me obey you."

GOD'S WORD & ME

When we love God more than anything,
we spend our time getting to know Him.

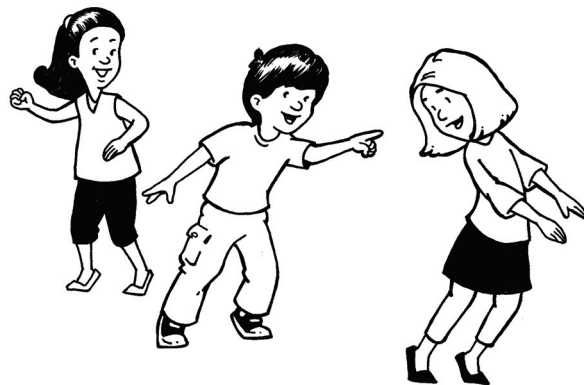

ART CENTER

FOR YOUNGER CHILDREN • LUKE 12:13-21

COLLECT

Bible, Lesson 9 Pattern Page (p. 168), four craft sticks, card stock, markers, glue, 18-inch (45.5-cm) lengths of yarn; optional—scissors.

PREPARE

Photocopy Lesson 9 Pattern Page onto card stock. Make a sample frame, following directions below.

DO

1. Give each child four craft sticks. Children glue sticks together as shown to form a frame and set aside to dry.
2. Give each child a copy of the Lesson 9 Pattern Page. Read words on pictures to children. Each child chooses one of the pictures, colors it and cuts it out. (Optional: For younger children, precut pictures.)
3. Child inserts yarn at top of frame. Tie yarn to form a hanger. Help each child glue the colored picture to the back of the frame.

TALK ABOUT

• **Every day there are ways we can show that we love God and want to obey Him. One way to obey is to listen to stories from the Bible. Who tells or reads you Bible stories?**

• **As you grow up, you will learn more and more about God. We can pray and ask God's help in getting to know Him. Lead children in a brief prayer. Dear God, we love You. We want to get to know You. Please help us every day.**

• **The Bible says, "I love you with all my heart. Help me obey you." Who are some people you love? (My mom. My dad. My friends.) We can love God, too. We can get to know what He is like.**

FOR OLDER CHILDREN

Instead of using the Lesson 9 Pattern Page, provide paper cut to fit the craft stick frames. Children draw pictures of themselves in ways they plan to spend time getting to know God.

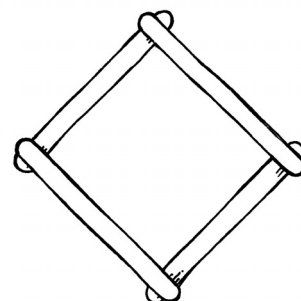
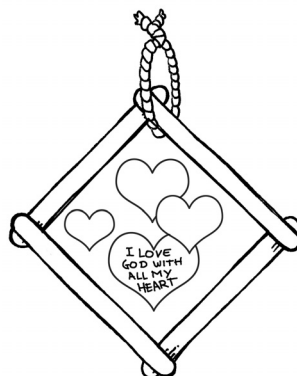
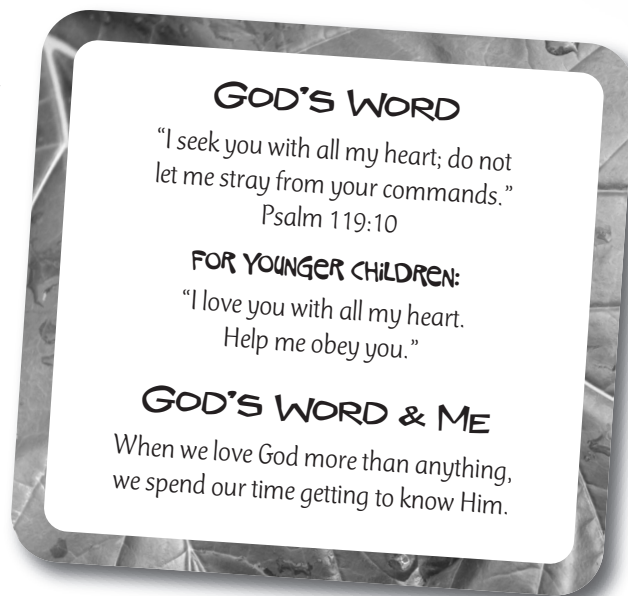

ART CENTER

FOR OLDER CHILDREN • LUKE 12:13-21

COLLECT

Bible, 1½x2-inch (3.8x5-cm) pieces of colored construction paper, thin-tip markers or pens, scissors, ½-inch (1.3-cm) magnetic tape, envelopes; optional—metal surface such as a cookie sheet.

PREPARE

Divide verse into four or five phrases. Print each phrase on a separate piece of paper. Cut magnetic tape into 1-inch (2.5-cm) pieces. Put a piece of tape on the back of each verse phrase.

DO

1. Set out the magnetic phrases you prepared. Let volunteers arrange phrases in verse order. (Optional: Arrange phrases on metal surface.)
2. Ask children to brainstorm with you slogans and messages that tell the importance of getting to know God and ways to spend time with Him (Get to Know God, Read the Word, Pray Always, Sing Praise, etc.).
3. Each child chooses several phrases and prints the words on pieces of paper. (Optional: Children may write additional words if time and supplies permit.) Children place tape on back of their papers and, as time permits, arrange them in order. Children take home words in envelopes and arrange words on refrigerator or other metal surface as reminders to spend time getting to know God.

TALK ABOUT

- **What are the differences between someone who spends time getting to know God and someone who forgets about God?** (Someone who gets to know God reads the Bible and listens to other Christians talk about God. He or she knows getting to know God is the most important thing in life.)
- Read Psalm 119:110 aloud with children. **How would you say “I seek you with all my heart” in your own words? What would you say is the best part of getting to know God?** (Helps me know that I can depend on God. I realize His love and plans for me.)
- **Who are some people that help you get to know God? How can you help others get to know God? What can you do and say?**

FOR YOUNGER CHILDREN

Provide a large index card in addition to a magnetic strip for each child. Children draw and color heart shapes on card. Print “(name) loves the Lord” on the papers. Remove adhesive backing from magnetic strip and let children attach to their papers.

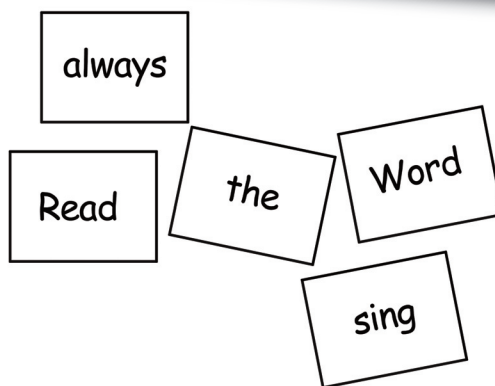

WORSHIP CENTER

LUKE 12:13-21

COLLECT

Bibles, *Parable Quest* CD-ROM and CD player, song charts (pp. 246, 254), plastic banana.

TEAM GAME

Play Hot Potato using a plastic banana. Children stand in a circle. Play music from CD as children pass banana around the circle. From time to time, stop the music. Whoever has the banana when the music stops, acts and sounds like a monkey. Be ready to participate with any child who hesitates.

BIBLE VERSE GAME

Repeat Psalm 119:110 aloud with children. Demonstrate the following actions for the phrase "I seek you": snap fingers for "I," clap hands for "seek" and high five someone for "you." Practice words and actions with children. Then invite a child to suggest actions for the phrase "with all my heart" (jump in place, turn around, pat shoulders, nod head, etc.). Continue until the entire verse has been quoted. Repeat verse and all motions several times.

SONG

You, or another leader, lead children in singing "Wise Up!" adding motions and/or clapping if desired.

PRAYER

Tell one way in which you plan to get to know God this week. Invite children to silently think of one way in which they want to plan to spend time getting to know God this week. Lead children in prayer, thanking God for His love for us and asking His help in keeping the plans made.

SONG

You, or another leader, lead children in singing "Following Jesus," adding motions and/or clapping if desired.

GOD'S WORD

"I seek you with all my heart; do not let me stray from your commands."
Psalm 119:10

FOR YOUNGER CHILDREN:

"I love you with all my heart.
Help me obey you."

GOD'S WORD & ME

When we love God more than anything,
we spend our time getting to know Him.



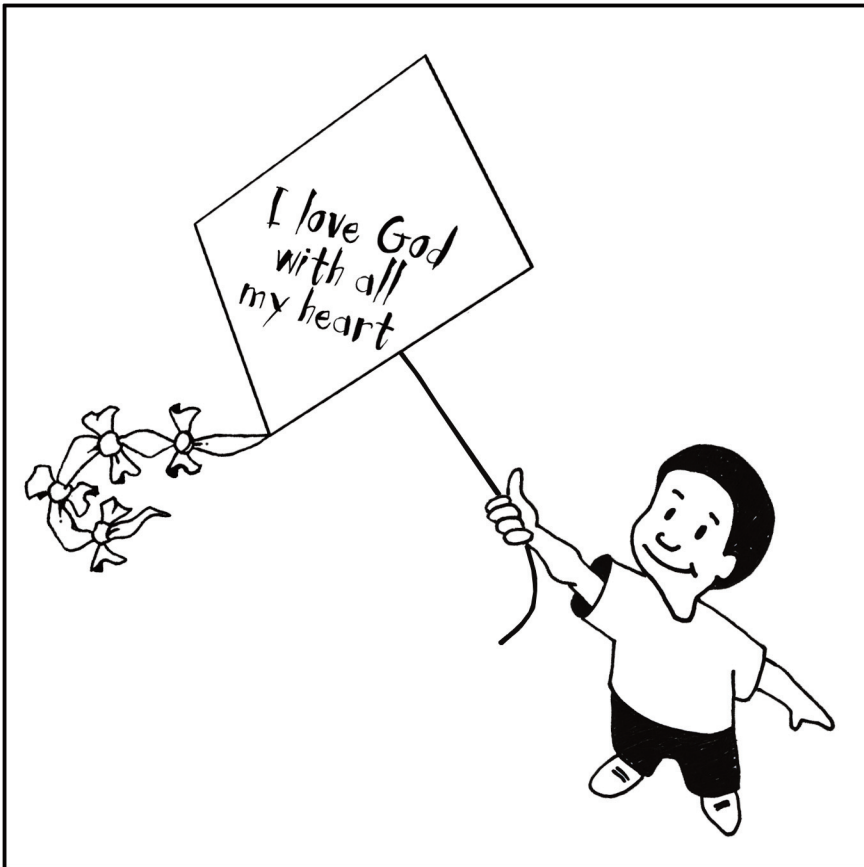
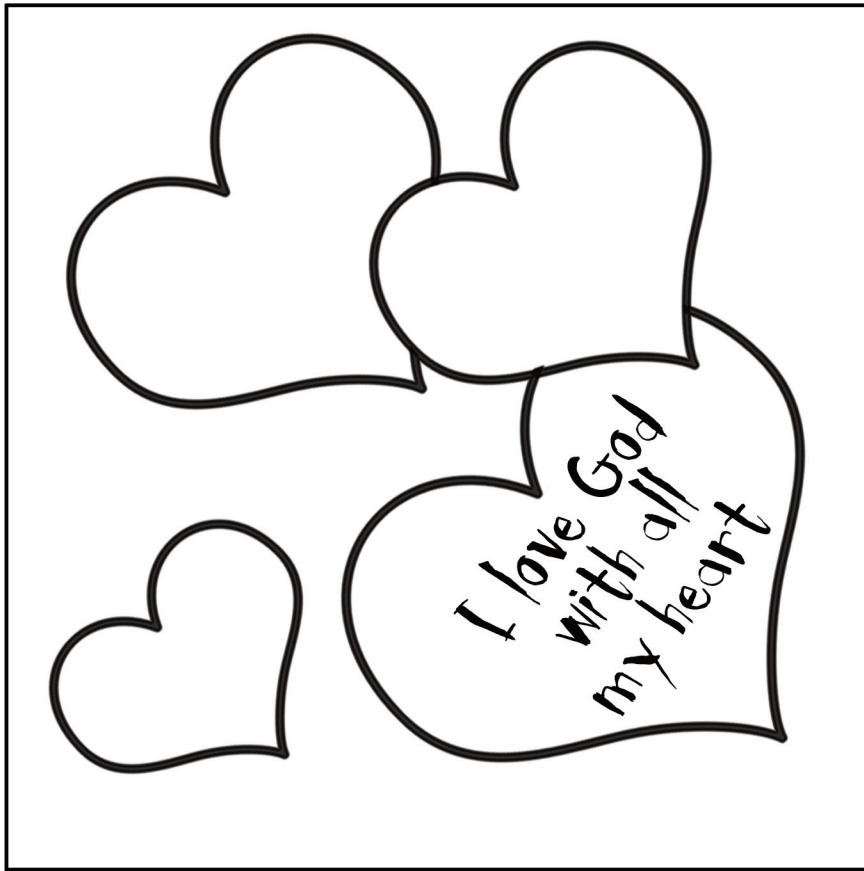

Jesus talks about a rich man.
Luke 12:13-21

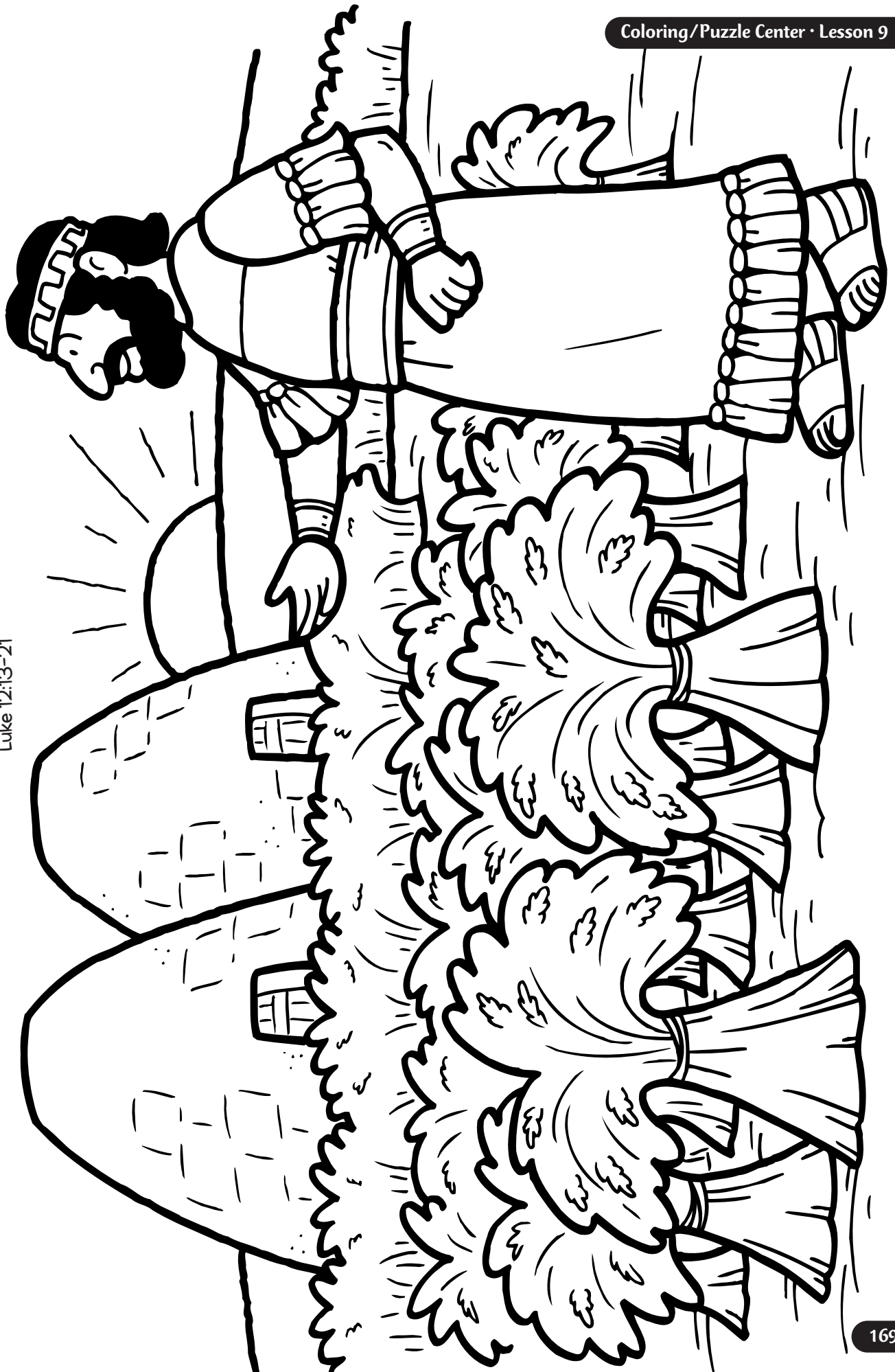

The rich man did not love and obey God. What can you do to love and obey God?

a HEART IN SHAPE!

Find the letter in each shape to discover how to make your heart strong!

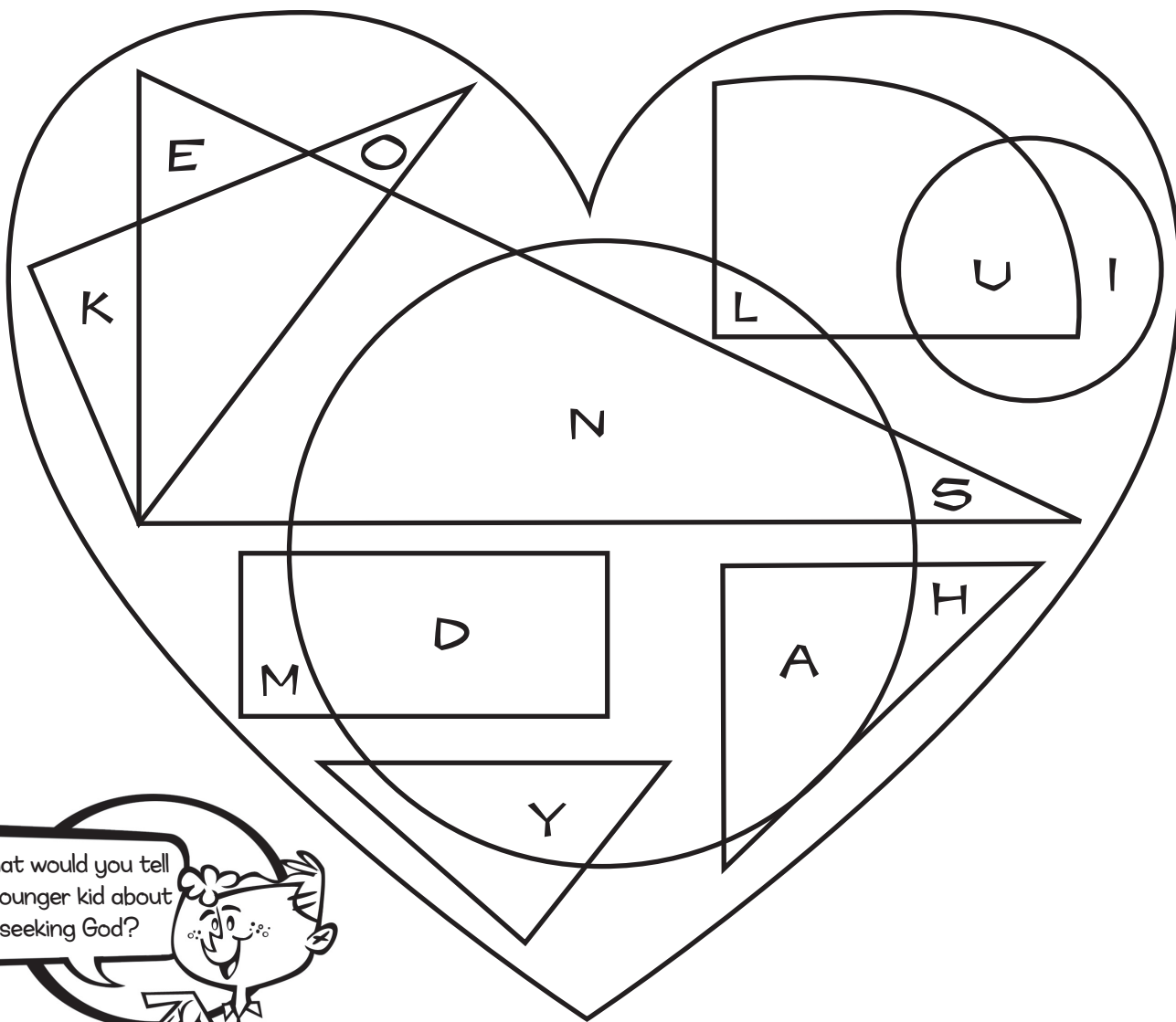

What would you tell a younger kid about seeking God?



GREAT BANQUET

LUKE 14:16-24

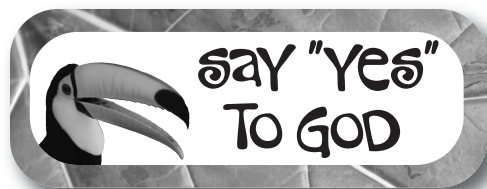

say "Yes"
To GOD

Teacher's Devotional

Imagine that a football fan has been invited to a Superbowl party—a party AT the Superbowl, thrown especially for family and friends of the players! Airfare is paid and the tickets are waiting. Do you think that the fan would likely stay home because the fan got a paper cut or needs to give the dog a bath? This might seem like an extreme example—but when it comes to the Kingdom of God, some people's behavior might make you think a paper cut DOES outweigh a Superbowl party invitation!

In a parable Jesus told to a Pharisee, He used a fabulous banquet as a symbol of the heavenly kingdom. Though a number of people accepted the initial invitation, they suddenly gave excuses about why they couldn't attend when it was time to go. A business deal (buying a field), possessions (oxen) and a personal relationship (marriage) were all deemed more important than the invitation to this lavish party. So the host gave the guests' places to others—including the blind, lame and poor. Jesus' well-educated Jewish listeners probably recognized that the story's "undesirables" might have been Gentiles and that the generous host represented God. To think that non-Jewish people—and undesirable ones at that—could be invited into God's kingdom would have shocked Pharisees who prided themselves on their ability to follow Jewish law to try to earn God's favor.

Today, business deals, material possessions and personal relationships still prevent people from putting God first. But through His boundless love, God continues to invite each of us to join the great banquet and to be part of His heavenly kingdom. There's nothing more important than saying "yes!" to His generous invitation. It's better than an exclusive Superbowl party, any day—and it's forever!



GOD'S WORD

"Here I am! I stand at the door and knock. If anyone hears my voice and opens the door, I will come in and eat with him, and he with me."
Revelation 3:20

FOR YOUNGER CHILDREN:

"Jesus says, 'Listen! When you hear about my love for you, be my friend.'"

GOD'S WORD & ME

Be ready to say "yes" to God's invitation so that you can enjoy life with Him now and forever.

PLANNING PAGE

Choose which centers you will provide and the order in which children will participate in them (see pp. 14-18 for schedule tips and pp. 24-25 for guidelines in combining older and younger children). Also plan who will lead each center (for staffing tips see pp. 19-21). Use the reproducible planning sheet (p. 238) to record your plans.

BIBLE STORY CENTER

BIBLE STORY

Great Banquet • Luke 14:16-24

ADVENTURE BOX (YOUNGER CHILD)

Use props (fancy-looking invitation card, a fancy plate, cup and utensils) to demonstrate story action

ADVENTURE BOX (OLDER CHILD)

Use props (fancy-looking invitation card, a fancy plate, cup and utensils) to demonstrate story action

ART CENTER

YOUNGER CHILD OPTION

Make and decorate cards as reminders of Jesus' offer of friendship

MATERIALS

Bible, card stock, paper in a variety of colors, scissors or paper cutter, glue sticks, crayons, marker

OLDER CHILD OPTION

Make and decorate yard signs about Jesus and His love and talk about ways Jesus shows His love

MATERIALS

Bible, paper, markers, card stock, bamboo skewers, masking tape

GAME CENTER

YOUNGER CHILD OPTION

Play a game walking around and jumping into circles made from hula hoops or yarn and then talk about how Jesus wants to be their friend

MATERIALS

Bible, several long lengths of yarn

OLDER CHILD OPTION

Play a game hopping from rock to rock in a "rainforest pond" and then describing situations in which knowing Jesus can help them

MATERIALS

Bible, *Parable Quest* CD-ROM and CD player, Lesson 10 Pattern Page (p. 182), masking tape

COLORING/PUZZLE CENTER

YOUNGER CHILD OPTION

Review the Bible story while completing coloring page

MATERIALS

Lesson 10 Coloring Page (p. 183) for each child, crayons

OLDER CHILD OPTION

Review Revelation 3:20 while completing puzzle page

MATERIALS

Lesson 10 Puzzle Page (p. 184) for each child, pencils

WORSHIP CENTER

FOR THE YOUNGER AND OLDER CHILD

Participate in large-group activities to review Bible verse and to worship God together

MATERIALS

Bibles, *Parable Quest* CD-ROM and CD player, song charts (pp. 246-247), inflated balloons (one for each team, plus several extras)

BONUS THEME IDEAS

Bonus Theme Ideas can be used at any time during this session: as an additional activity center, to extend the session for a longer time, or for added theme excitement.

RAINFOREST MIX

Collect several measuring cups, bowls, large spoons, disposable cups and at least three of these rainforest foods: banana chips, cashew nuts, dried pineapple chunks, coconut flakes, chocolate chips. Children take turns measuring 1 cup of each ingredient into bowls and stirring to mix. Each child dips cup into bowl to fill halfway and enjoys this rainforest trail mix. (Optional: Provide each food in a separate bowl. Child chooses foods and uses plastic spoon to place several spoonfuls in his or her cup.)

Post a note alerting parents to the use of food. Also, check registration forms for possible food allergies.



RAINFOREST TUG OF WAR

Place a strip of masking tape in an open area of the room. Divide group into two teams. Invite two volunteers from each team to participate in Double Trouble Tug-of-War. Two volunteers stand and hold opposite ends of a jump rope. Player who pulls the opposing player over the masking-tape line wins the round. Teams participate in several rounds of increasing challenge, with different players participating in each round. (Round 1: Stand backwards and pull the rope; Round 2: Hold rope with one hand; Round 3: Hold rope with one hand and stand on one foot; etc.) Keep a tally of points, doubling the number of points you give to the winning team, or just enjoy the game for the fun!

WONDERFUL WATERFALLS

Prepare a place (outdoor sand area, large plastic containers, or sand-and-water table) where children can create with sand, small rocks and stones and water. Provide a variety of sand tools and plastic tubes or pipes. **In the rainforest, there are lots of rivers and waterfalls.** Children build rivers and pools using the sand, rocks and stones. Encourage children to see if they can build a waterfall at one end of a river or by a pool. Provide water in pitchers for children to pour into rivers or to create waterfalls. Children may also pour water through plastic tubes and pipes.

BIBLE STORY CENTER

FOR YOUNGER CHILDREN • LUKE 14:16-24

INTRODUCTION

Welcome your rainforest explorers by saying **I went to the rainforest and I saw a (monkey)**. Lead children to take turns naming other animals and repeating the list with every turn. Then show Adventure Box. **What do you think is in our Adventure Box today? Let's find out!** Untie box. Remove items from box and use them to demonstrate story action as you tell the story.



ADVENTURE BOX

In a cardboard or wooden box labeled "Adventure," place a Bible, a fancy-looking invitation card, a fancy plate, cup and utensils. Tie rope or brown yarn around the box or crate.

TELL THE STORY

Jesus was eating dinner with a group of people. As they ate, Jesus told a story to help these people understand something very important about God's family.

(Set out dishes and utensils as you speak as if setting a fancy table.)

"A man planned to have a big party at his house. There would be lots of good food and music. When everything was ready, the man sent his servant to tell the guests that it was time to come. *(Show invitation and invite children to pass it.)*

"But when the guests heard the news that it was time to come to the party, they didn't get ready to go! Instead, the guests made excuses about why they could not come to the party!

"One guest said he was too busy looking at the oxen (like cows) that he had just bought. Another guest said he needed to go look at some land he had just bought. And another man said he had just gotten married. He was too busy with his new wife.

"The man giving the party heard all these excuses, but he still wanted to have the party! So the man told his servant to bring all of the poor, the blind, the crippled and the lame people to his house for the feast.

"The servant ran through the streets. He asked everyone he saw who was poor, blind, crippled or lame to come to the party. And they all came! Some people carried others who couldn't walk. Other people led those who couldn't see. Finally the whole banquet hall was filled up. They ate delicious food and heard lovely music. Everybody had a wonderful time—except those people who made excuses and did not come to the party!"

GOD'S WORD & ME

Jesus told this story to remind us that no one should make an excuse when God invites us to be a part of His family. God loves all people. He doesn't want anyone to miss a chance to know Him. In the Bible, Jesus says, "Listen! When you hear about my love for you be my friend." Jesus wants us to be part of His family. We want to always be ready to say "yes" to Him. Pray, Dear Jesus, thank You for loving us. Thank You for wanting us to be part of Your family. We love You. Amen.



BIBLE STORY CENTER

FOR OLDER CHILDREN • LUKE 14:16-24

INTRODUCTION

Let's play "Best Party Ever"! Here's how to play: I could say, "I had the best party ever and we ate banana splits." The word that completes the next sentence has to begin with the last letter of the previous word. So, the next person's idea has to begin with S. That person could say, "I had the best party ever and we played soccer." Children play until everyone has added an idea for the best party ever. **Those are all great party ideas. Today we're going to hear a story Jesus told about an amazing party!**

What do you think is in our Adventure Box today? Let's find out!

Untie box. Remove items from box and use them to demonstrate story action as you tell the story.



ADVENTURE BOX

In a cardboard or wooden box labeled "Adventure," place a Bible, a fancy-looking invitation card, a fancy plate, cup and utensils. Tie rope or brown yarn around the box or crate.

TELL THE STORY

One day Jesus was having dinner with a religious leader called a Pharisee. A Pharisee is someone who tried very hard to obey every part of the religious laws in Jesus' time. This man and his friends were watching Jesus carefully, looking to see if He did anything wrong. They wanted Jesus to do something wrong, so they could criticize him. During the meal, Jesus told them this parable.

Once there was a wealthy man who had a wonderful idea! "I'll plan and prepare a great banquet," he decided, "and invite my friends to come. I'll serve them a dinner they'll NEVER forget!" In Bible times, a banquet might last for many days. People sometimes traveled long distances to attend. In many cases, the invited guests stayed overnight at their host's home, ate his food and were entertained by musicians and dancers. Invitations would be sent out early. Later, those who had said they could come would be reminded or sent for when the banquet was actually ready.

So first, the man sent invitations to his friends to come to the party. "Come to my party, dear friends! We'll enjoy a great banquet together!" And his friends replied, "Of course, we'll be there!"

Finally the big day arrived! He sent his servant to each invited guest to tell them: "Now everything is ready. Come to the banquet!"

The man's servant came to the home of one of the invited guests and said, "Come now to the banquet! Our master is waiting for you to be there as you promised."

But the first invited guest said, "I've just bought a field, and I must go and see it. Sorry, but I can't come after all." The servant continued on to the next invited guest. He said, "Come now to the banquet! Our master is waiting for you to be there as you promised." "If only it were at a different time," the invited guest shrugged. "I've just bought some prize oxen. (Oxen are like cows.) I must examine them, weigh them and be sure that they are just what I wanted. Tell your master it is now simply impossible for me to come."

Finally, the servant went to the house of *another* man who had been invited. He said, "Come now to the banquet! Our master is waiting for you to be there as you promised." The man replied, "Oh, sorry, I can't come after all. I've just gotten married! I'm much too busy to attend."

The host waited at home and finally he heard the sound of footsteps in the courtyard. But it was his servant, returning with the sad news.

The man was UPSET when he heard about his guests' refusals! He had planned so many wonderful surprises for them. Yet, they had made excuses and broken their promises to attend. But instead of cancelling the party, the man gave his servant a new command.

"Quickly," he commanded, "go into the city! Tell everyone you see to come to my banquet! Invite the poor families who are hungry! Bring back the disabled ones and the blind beggars!"

So the servant ran through the city streets and down the back alleys. “Come now to the banquet! Our master is waiting for you!” And they did! The poor carried those who couldn’t walk. Lame people led the blind people. All of them entered the beautiful banquet hall. When they were seated, the servant reported to the master.

“Sir, what you commanded has been done—but there’s still room left in the hall.”

“Go out again,” insisted the master. “This time go out to the highways. Find those who are tired of traveling, those who are resting beside the roads. Find the homeless ones who sleep under the bridges. I want my house to be FILLED with guests!”

Once again, the servant set out. Soon he returned with MORE guests. At last the banquet hall was FULL! And what a sight! These guests had never eaten such delicious food. Never had they heard such lovely music or seen such fascinating entertainment. There was laughter and songs and the hall echoed with happy voices. The master was satisfied with his party! He said, “I tell you, not one of those men who was invited will get a taste of my banquet.”

Jesus’ story clearly warned against making excuses to God when He invites us to become part of His family.

GOD’S WORD & ME

Sometimes kids might think that God’s invitation to join His family is just for grownups, or they make an excuse, saying, “I’ll think about that later.” But God wants us to be people who listen now and obey Him now—especially when it comes to joining His family!

- **What do you think of the excuses of the people who were invited to the banquet?** (They were bad excuses! They showed the people invited really didn’t care about their friend.)
- Invite a child to read Revelation 3:20 aloud. **What do you think Jesus means by eating together?** (Having a relationship, a friendship.)
- **What happens if we don’t open the door to Jesus?** (We miss out on God’s salvation.) **Just as the generous man who planned the party showed love and invited everyone to come who wanted to, God loves everyone and wants them to accept His invitation to become part of His family! Don’t miss out on life with Him now and forever!** Pray with children, asking God’s Spirit to help them know how much God loves them and offers them salvation through Jesus. Invite children interested in talking about joining God’s family to meet with you after class (see page 12 for “Leading a Child to Christ”).



GAME CENTER

FOR YOUNGER CHILDREN • LUKE 14:16-24

COLLECT

Bible, several long lengths of yarn.

PREPARE

On the floor, use yarn to form several circles 6 feet (1.8 m) in diameter. Use one circle for each group of up to six children.

DO

1. Children sit around yarn circles. One player in each circle is chosen as "It" and begins to walk around the outside of the circle. "It" taps someone on the back, and that child stands and begins to walk around the circle, following the first child. (Optional: Demonstrate the game action yourself in a practice round.) Then the second child taps a third child and that child begins to walk around following the first and second children. Play continues until all children in the circle are walking around the circle. Call out "Come to the circle!" All children jump into the circle.
2. Children sit in circle again. Play game again with a new child acting as "It." Repeat as time permits.

TALK ABOUT

- In this game, we tapped people to show that we wanted them to come be with us. Then it was fun to jump into the circle together to be with all our friends. Who are some of your friends?
- Jesus wants to be your friend, too. In the Bible, Jesus says, "Listen! When you hear about My love for you, be my friend." Jesus loves each of you so much! And Jesus is the best friend we can ever have!
- Jesus can help us every place that we go. Where are some of the places you go? (Church. Preschool. Babysitter. Park.) Jesus helps us by giving us people to take care of us.
- Let's pray and thank Jesus for loving us and for wanting to be our best friend. Pray briefly, Dear Jesus, thank You for loving (name children in your group). Thank You for helping us and being our friend. Amen.

FOR OLDER CHILDREN

Make the circles larger, playing outdoors if possible. Instead of walking around the circle, children run. When all children have jumped inside the circle, lead them in repeating Revelation 3:20.

GOD'S WORD

"Here I am! I stand at the door and knock. If anyone hears my voice and opens the door, I will come in and eat with him, and he with me."
Revelation 3:20

FOR YOUNGER CHILDREN:

"Jesus says, 'Listen! When you hear about my love for you, be my friend.'"

GOD'S WORD & ME

Be ready to say "yes" to God's invitation so that you can enjoy life with Him now and forever.

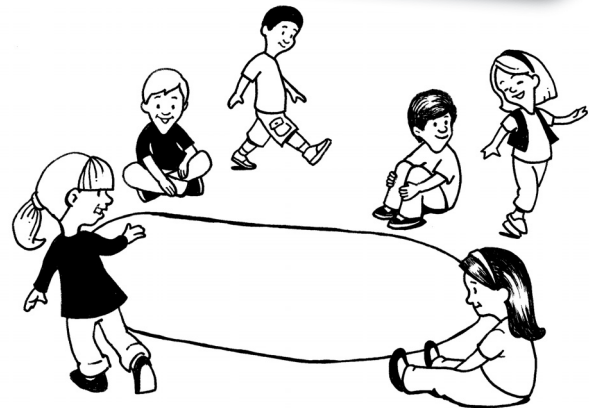

GAME CENTER

FOR OLDER CHILDREN • LUKE 14:16-24

COLLECT

Bible, *Parable Quest* CD-ROM and CD player, Lesson 10 Pattern Page (p. 182), masking tape.

PREPARE

Photocopy Lesson 10 Pattern Page and cut apart to form “rocks” in a rainforest pond. Make at least one rock for each child. Use masking tape to create three large concentric squares on the floor. Adjust size of squares according to the number of children you estimate will be playing this game. Lightly tape one edge of each rock to masking tape squares as shown in sketch.

DO

1. Divide group into three equal teams. Team one stands on rocks in outer square. Team two stands on rocks in center square and so on. (It's OK if there is not a player standing on each rock.)
2. **In this game, see if you can hop around in this rainforest pond.** As you play “Following Jesus,” children hop clockwise around squares from rock to rock. After 10 to 15 seconds, stop the music and have children sit down.
3. Choose a child from each square to pick up the nearest rock. Children read words on their rocks. Any child uses the words on the rocks to tell a situation in which a child his or her age might be: “A kid goes with his friend to the park and they get lost.” (Tip: Be prepared to tell a situation before asking children to give their ideas.) Talk with children about how it helps to know that Jesus is with them in the described situation. Children tape rocks to floor again. Repeat game as time permits, each time choosing different children to pick up rocks.

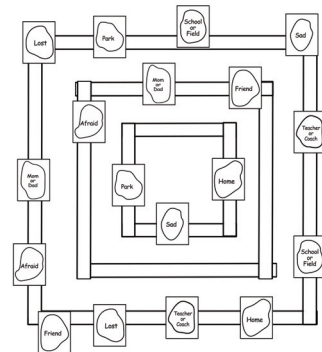

GOD'S WORD

“Here I am! I stand at the door and knock. If anyone hears my voice and opens the door, I will come in and eat with him, and he with me.”
Revelation 3:20

FOR YOUNGER CHILDREN:

“Jesus says, ‘Listen! When you hear about my love for you, be my friend.’”

GOD'S WORD & ME

Be ready to say “yes” to God's invitation so that you can enjoy life with Him now and forever.

TALK ABOUT

- **In our game today we're talking about the difference it can make in our lives when we remember that Jesus is with us. What do you know about Jesus? What words would you use to describe Him?**
- **Listen to what Jesus said in the Bible.** Read or have a child read Revelation 3:20. **This verse means that Jesus is inviting us to accept His love and become part of God's family. Then we can depend on Jesus' help everywhere we go.**
- **When have you been in a situation like this? What happened? Why would it be important to remember Jesus' love and help in that situation?** (Remind us to pray and ask Jesus what to do. Helps us remember Jesus' promises to us.)

FOR YOUNGER CHILDREN

Be ready to read words on cards with children, and talk with them about age-appropriate situations in which children can ask Jesus, their Friend, for help.

ART CENTER

FOR YOUNGER CHILDREN • LUKE 12:13-21

COLLECT

Bible, card stock, paper in a variety of colors, scissors or paper cutter, glue sticks, crayons, marker.

PREPARE

Fold each sheet of card stock in half to make a card. Cut paper in strips of various lengths and at least 1 to 2 inches (2.5 to 5 cm) wide. Make a sample card.

DO

1. Show your sample card and read the words inside to children. Give each child a prepared card.
2. Children choose strips and glue them onto front of card in a pattern of their own choosing.
3. Print "Jesus is (Zoey's) friend" on the inside of the card, saying the words aloud as you print them. Child decorates the inside of the card and takes it home as a reminder of Jesus' love for him or her. Suggest children draw themselves, happy faces, trace their hands, etc.

TALK ABOUT

- **Today you get to make a card that you can take home as a reminder that Jesus loves you and is your friend. In the Bible, Jesus says, "Listen! When you hear about My love for you, be My friend." Jesus loves each of you so much! And Jesus is the best friend we can ever have!**
- **Because Jesus loves us and is our friend, He helps us have the things that we need. What are some foods you like to eat? What are some animals you like to see?**
- **No matter where we go, or how young or old we are, Jesus can be our friend and help us. Where would you like to go? What would you like to do when you are older? Jesus will always love you!** Pray briefly, thanking Jesus for His love and for being our friend.

FOR OLDER CHILDREN

Cut strips the width of the cards, but cut them at various angles (wide at one end of the strip and narrow at the other end of the strip). Children fit them together on the front of their cards before gluing them into place. Have children write a prayer to Jesus on the inside of their cards before drawing designs of their own choosing.

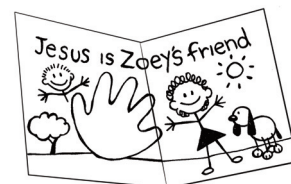
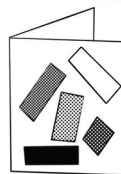
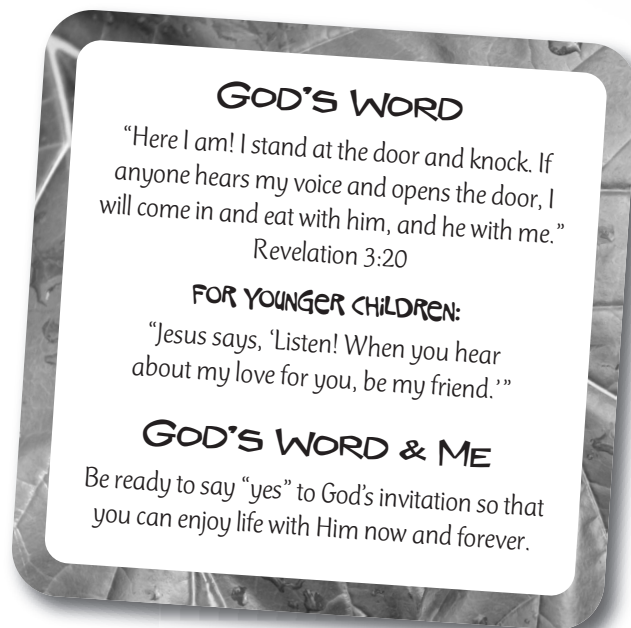

ART CENTER

FOR OLDER CHILDREN • LUKE 14:16-24

COLLECT

Bible, paper, markers, card stock, bamboo skewers, masking tape; optional—clear Con-Tact® paper, scissors.

PREPARE

Make a sample yard sign as instructed below.

DO

1. Read Revelation 3:20 to children and then ask them to suggest sentences that either describe Jesus or encourage people to accept His love (Jesus wants to be your friend. Jesus is my friend now and forever. Don't miss out on life with Jesus! Say "yes" to Jesus). Print sentences on paper for all to see. Help children determine how to divide each sentence into three parts.
2. Give each child three sheets of card stock. Child makes yard signs by choosing a sentence and writing it on card stock in large letters, one part of the sentence on each sheet of card stock. Child may also add decorations to their signs. (Optional: Cut Con-Tact paper to fit signs and cover signs for durability.)
3. Child tapes each completed sign to a bamboo skewer. Ask each child to tell where they will display their signs, or children may stick them in the ground or lawn of your church facility.

TALK ABOUT

- **What are some of the important things you think kids your age need to know about Jesus?** (Jesus is God's Son. Jesus always loves us. Jesus died on the cross to take the punishment for sin.) **What important things do you learn about Jesus from His words in Revelation 3:20?** (Jesus wants to be our friend. He wants us to be part of God's family.) Have a child read verse aloud from Bible.
- **Sometimes kids think they can wait until they are grownups to pay attention to Jesus' words. But why do you think it's important to say "yes" to Jesus' love and offer of salvation now?** (To experience Jesus' love and help right away. To rely on Jesus for making good choices.)
- **What are some of the reasons people can depend on Jesus to be a friend who helps them now and forever?** (Jesus' love lasts forever. Jesus keeps His promises. Jesus cares about each person.) Pray, thanking Jesus for His love and friendship.

FOR YOUNGER CHILDREN

Print "Jesus loves you" on signs. Some children may be able to copy your letters and write their own signs. Child decorates his or her sign and attaches to skewer and displays as directed above.

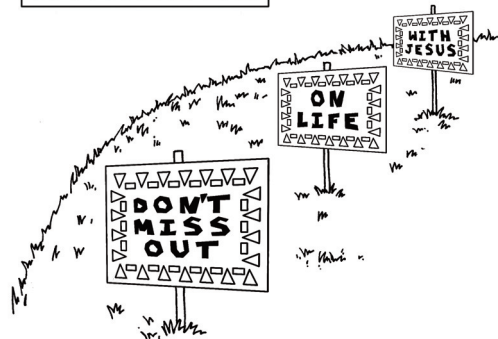
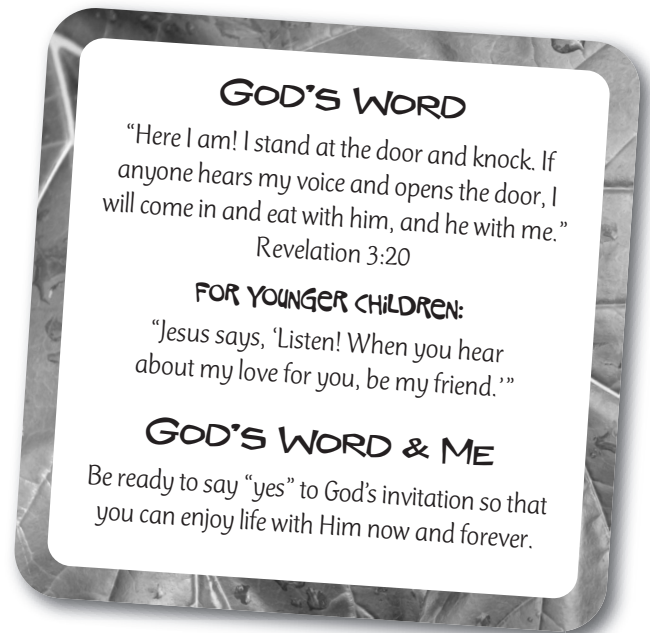

WORSHIP CENTER

Luke 14:16-24

COLLECT

Bibles, *Parable Quest* CD-ROM and CD player, song charts (pp. 246-247), inflated balloons (one for each team, plus several extras).

TEAM GAME

Help children form teams of up to 10 players each. Teams line up at one end of an open area of the room. Give first player on each team an inflated balloon. At your signal, child places balloon between knees and walks to other side of the room, removes balloon and holds it while running back to team. Continue until each child has had a turn.

BIBLE VERSE GAME

Repeat Revelation 3:20 aloud with children. **Jesus talks about knocking on a door and opening a door. What Jesus means is that He wants to be a part of our lives. He wants to be our friend. When we open the door, it means we accept Jesus' love and offer of salvation.**

Children walk around the room while you play "Song Name to Come" on CD. After 10 to 15 seconds, stop the music. Each child finds a partner. (Be ready to be a partner with a child if needed.) Lead one person in each pair to say the first part of the verse prefaced by "Jesus said." After saying the words "door and knock," children who were speaking knock on the floor. Then lead the other person in each pair to say the rest of the verse, again prefacing it by saying "Jesus said." Repeat several times as time permits.

SONG

You, or another leader, lead children in singing "God Gave" adding motions and/or clapping if desired.

PRAYER

Jesus wants everyone to accept His love and be part of His family. Invite children to tell names of people for whom they would like pray. Lead children in prayer, including the names children mentioned.

SONG

You, or another leader, lead children in singing "Following Jesus," adding motions and/or clapping if desired.

GOD'S WORD

"Here I am! I stand at the door and knock. If anyone hears my voice and opens the door, I will come in and eat with him, and he with me."
Revelation 3:20

FOR YOUNGER CHILDREN:

"Jesus says, 'Listen! When you hear about my love for you, be my friend.'"

GOD'S WORD & ME

Be ready to say "yes" to God's invitation so that you can enjoy life with Him now and forever.



Friend

Teacher
or
Coach

Lost

Mom
or
Dad

Park

School
or
Field

Sad

Home

Afraid

Jesus tells about a big party.

Luke 14:16-24

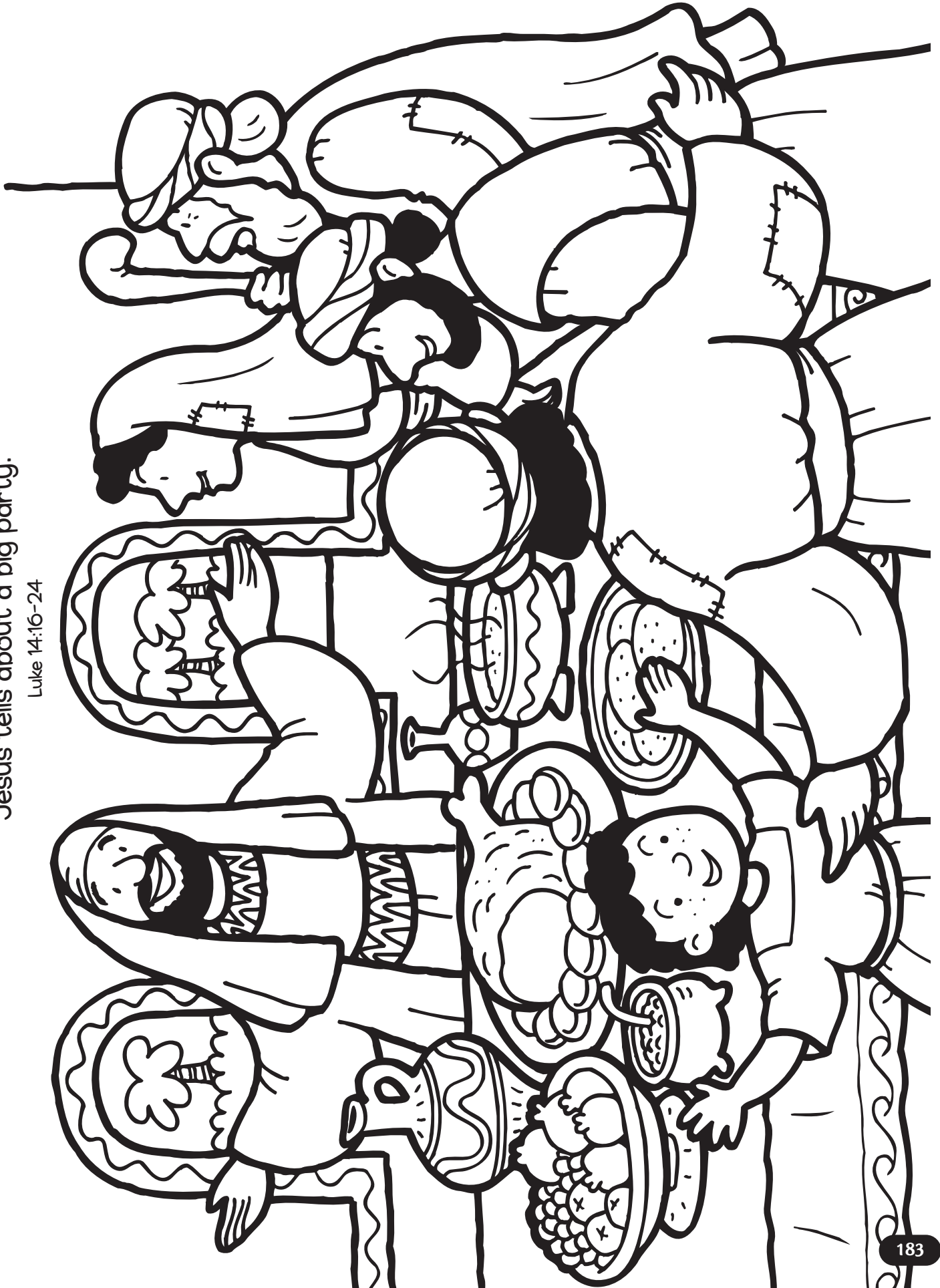

Jesus loves you and wants to be your friend. Who are some other people Jesus loves?

a PUZZLING INVITATION!

Some of the letters fell off this invitation! They're all vowels. Help Henry figure out what it says.

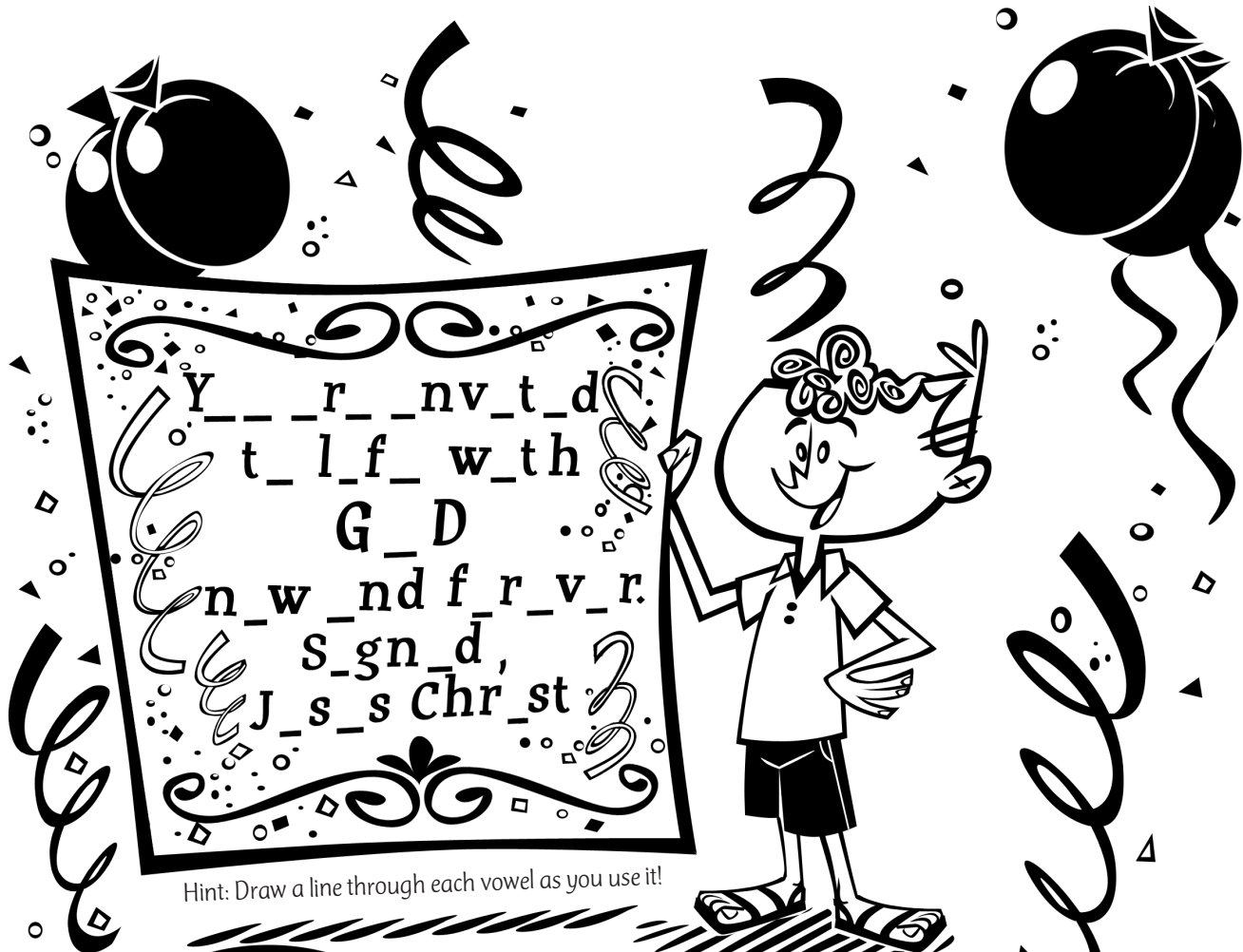

Hint: Draw a line through each vowel as you use it!

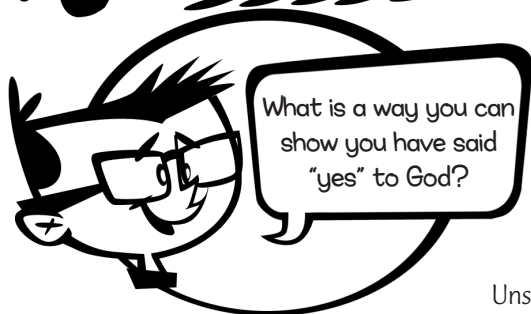

e u i e e o i e
i i e a o i e a i o
o o i e e o u

Unscramble the words on the balloons below to help Henry answer!

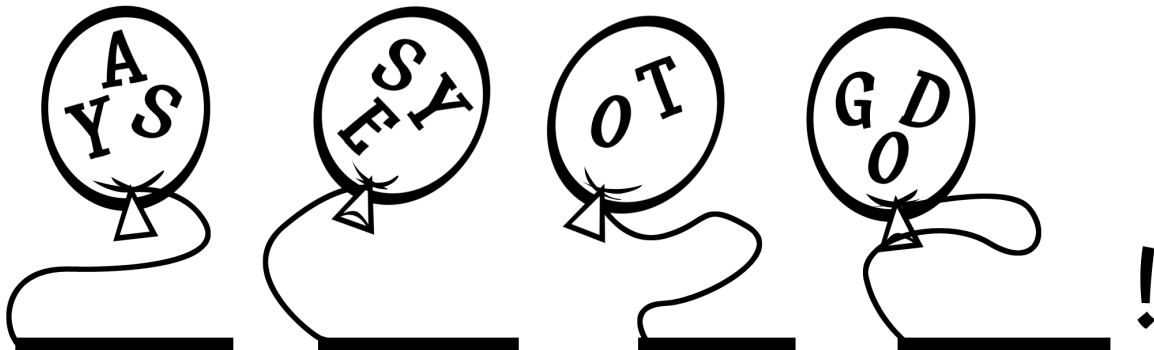

PRODIGAL SON

LUKE 15:11-32

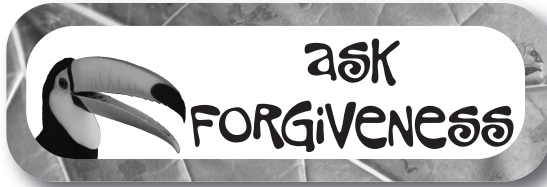

Teacher's Devotional

Can you imagine what might happen worldwide if people everywhere began to forgive each other? A number of wars would cease; murder cases would nearly disappear. A host of angry, bitter feelings would dissolve and the amount of peace and understanding would increase exponentially! Sadly, forgiveness doesn't flow all that easily, does it? Even in Jesus' story of the forgiving father, forgiveness stops at the older brother! He is unwilling to forgive a little brother whom he feels doesn't merit forgiveness; in fact, he's angry because his younger sibling is so readily forgiven by his loving father!

No matter how much we want to be forgiven ourselves, we often think that for others forgiveness must be deserved. We term some offenses "unforgivable" and are disturbed to see forgiveness extended to mass murderers, gross polluters, child molesters or those who deeply hurt us, to name a few. (If your particular "unforgivable" category wasn't named, fill in the blank. You know which one it is!) We have a tendency to want to take God's place when it comes to others' sins, weighing in on whether or not they should be forgiven!

The good news is that we are all hopelessly, equally sinful in the eyes of a perfect, holy God. What makes that good news is that we can freely confess our sin of judging others—or any other sin! Our loving Father is faithful to His promise to forgive us. He is just and perfect in His mercy to forget our sin. And then, like the woman who washed Jesus' feet with her tears (see Luke 7:36-38), we can remember how much we have been forgiven and can pray for other sinners rather than judge them—for we're all in need of the same forgiveness!

GOD'S WORD

"If we confess our sins, he is faithful and just and will forgive us our sins and purify us from all unrighteousness."
1 John 1:9

FOR YOUNGER CHILDREN:

"If we tell God we are sorry for our sin, he will forgive us."

GOD'S WORD & ME

When we've disobeyed God, if we ask for forgiveness, God's constant love is shown by His forgiveness.

PLANNING PAGE

Choose which centers you will provide and the order in which children will participate in them (see pp. 14-18 for schedule tips and pp. 24-25 for guidelines in combining older and younger children). Also plan who will lead each center (for staffing tips see pp. 19-21). Use the reproducible planning sheet (p. 238) to record your plans.

BIBLE STORY CENTER

BIBLE STORY

Prodigal Son • Luke 15:11-32

ADVENTURE BOX (YOUNGER CHILD)

Use props (sack of real or plastic coins, several party items [hats, streamers, cups, plates, etc.] and stuffed animal pig) to demonstrate story action

ADVENTURE BOX (OLDER CHILD)

Use props (sack of plastic or real coins, several party items [hat, streamers, cups, plates, snacks], stuffed animal pig, Bible-times robe and a fancy ring) to demonstrate story action

GAME CENTER

YOUNGER CHILD OPTION

Play a musical game with fast and slow movements and then talk about how fast the father in Jesus' story forgave His son

MATERIALS

Bible, rhythm instrument (shaker, tambourine, drum, etc.)

OLDER CHILD OPTION

Walk on a "trail" of footprints to repeat 1 John 1:9 and talk about what it means to confess sin to God

MATERIALS

Bible, construction paper, scissors, marker, masking tape

ART CENTER

YOUNGER CHILD OPTION

Make and decorate flags as reminders of God's love and forgiveness

MATERIALS

Bible, small and large construction paper in a variety of colors, scissors, tape, markers, stickers, adhesive craft foam shapes

OLDER CHILD OPTION

Make and decorate bookmarks about 1 John 1:9 and talk about the importance of knowing God's forgiveness for sin

MATERIALS

Bible, Lesson 11 Pattern Page (p. 196), clear Con-Tact® paper, card stock, scissors, paper, thin-tip markers

COLORING/PUZZLE CENTER

YOUNGER CHILD OPTION

Review the Bible story while completing coloring page

MATERIALS

Lesson 11 Coloring Page (p. 197) for each child, crayons

OLDER CHILD OPTION

Review 1 John 1:9 while completing puzzle page

MATERIALS

Lesson 11 Puzzle Page (p. 198) for each child, pencils

WORSHIP CENTER

FOR THE YOUNGER AND OLDER CHILD

Participate in large-group activities to review Bible verse and to worship God together

MATERIALS

Bibles, *Parable Quest* CD-ROM and CD player, song charts (pp. 249, 251), large sheet of paper, marker

BONUS THEME IDEAS

Bonus Theme Ideas can be used at any time during this session: as an additional activity center, to extend the session for a longer time, or for added theme excitement.

RAINFOREST FLOWERS

Each child places a shoestring licorice on a plate as a flower stem and then creates flowers. Provide sliced bananas or kiwis for flower centers. Provide raspberries, strawberries cut in half and orange sections as flower petals. If desired, real mint leaves can be added to the stems.

Post a note alerting parents to the use of food. Also, check registration forms for possible food allergies.



FAMILY FUN EVENT

Plan a special event designed to build relationships among families and between the church and the community. Send home invitations (see p. 233) several weeks ahead of time. Ask families to bring their favorite outdoor sports equipment (soccer balls, footballs, jump ropes, Frisbees, etc.). Have several parents as designated game leaders. Game leaders guide families in playing games and beginning new games at appropriate times. (Optional: Plan an egg toss or water balloon toss in which all families can participate at the same time.) After 30 to 40 minutes of game time, serve a pizza meal, barbeque hotdogs or enjoy one of the snacks suggested in the Bonus Theme Ideas for each lesson.

THE PARROT GAME

Parrots live in the rainforest and they are very good at imitating the sounds they hear. The object of this game is for you to be rainforest parrots! The challenge is to accurately mimic what I say and do. Ready? Repeat after me! Begin a variety of actions, repeating each action for 10 to 12 seconds: clap in patterns, make funny noises and move in silly ways. Children imitate you. As children catch on to the game, make your moves, claps and sounds more and more complicated and harder to follow.

BIBLE STORY CENTER

FOR YOUNGER CHILDREN • LUKE 15:11-32

INTRODUCTION

Hold an item from the rainforest (stuffed animal jaguar or monkey, rain stick, artificial flower, etc.). Welcome your rainforest explorers by saying **I'm going to pass the (monkey) to someone who is wearing blue tennis shoes.** Children look to find the person. When person is identified, give him or her the (monkey). Then describe another child. Continue until each child has been identified. End the game by describing a characteristic of yourself, so that children will pass the (monkey) back to you. Then show Adventure Box. **What do you think is in our Adventure Box today? Let's find out!** Untie box. Remove items from box and use them to demonstrate story action as you tell the story and/or lead children in suggested motions.



ADVENTURE BOX

In a cardboard or wooden box labeled "Adventure," place a Bible, a sack of real or plastic coins, several party items (hats, streamers, cups, plates, etc.), stuffed animal pig. Tie rope or brown yarn around the box or crate.

TELL THE STORY

Let's listen to a story Jesus told of a brother who went far from his home and family.

Once there was a father with two sons. They lived on a big farm. The father loved his sons. One day the younger son said, "Father, you promised to give me money some day. I want it NOW!" So the father gave his son the money. *(Hold sack of coins, stand and walk in place. Invite children to join you in story actions.)*

The son packed his clothes and left home. The father felt sad. *(Wave and look sad.)*

When the son got to a new place, he spent lots of money. *(Set out party items.)* He had lots of parties and made lots of new friends. His new friends helped him spend his money until it was all gone! *(Remove coins from sack and place in Adventure Box.)* His nice clothes became dirty and torn. Soon he didn't have enough food to eat. *(Rub tummy and look sad.)*

The son was so hungry, he went to work feeding some pigs. *(Show stuffed animal pig.)* It was NOT a job he liked to do! As he worked, the son thought, *Even the men who work for my father have food to eat.* The son decided, *I'll go back home. I'll ask my father to make me one of his servants!*

So the son began walking toward home. *(Walk in place.)* When he could see his father's farm, he could see someone running down the road toward him! *(Run in place.)* It was his FATHER. His father was running to meet him!

"Oh, Father," the son said, "I spent ALL the money you gave me. I am very sorry." His father grabbed him up in a big HUG! *(Hug self.)* He told the servants, "Make a big dinner. I want to CELEBRATE! I am very GLAD my son has come back home!"

The father gave his son new clothes and shoes. The son was so VERY glad that his father loved him and forgave him!

GOD'S WORD & ME

Jesus told this story to help us learn that God is good and kind, just like the father in the story. He will forgive us when we ask Him to. The Bible says, "If we tell God we are sorry for our sin, he will forgive us." We are glad God forgives us when we tell Him that we have done wrong. Pray, Dear God, thank You for loving us and forgiving us when we are sorry and ask forgiveness. We love You. In Jesus' name, amen.



BIBLE STORY CENTER

FOR OLDER CHILDREN • LUKE 15:11-32

INTRODUCTION

Let's play "Walk this way." It's a game where you show how you feel by the way you walk. Walk like you're really happy. Very good! Now, walk in place like you're sad. Children respond. Walk in place like you're proud of yourself. Children respond. Walk like you are hungry. Children respond. Walk in place as if you're afraid. Children respond. How would you walk if you saw someone you were REALLY glad to see? Listen to find out how each of these actions is part of our story today!

What do you think is in our Adventure Box today? Let's find out! Untie box. Remove items from box and use them to demonstrate story action as you tell the.



ADVENTURE BOX

In a cardboard or wooden box labeled "Adventure," place a Bible, sack of plastic or real coins, several party items (hat, streamers, cups, plates, snacks), stuffed animal pig, Bible-times robe and a fancy ring. Tie rope or brown yarn around the box or crate.

TELL THE STORY

Jesus once went to eat dinner with some people who were considered sinners by the religious leaders. Those leaders began to say that Jesus was wrong to be friendly to people who did bad things. Well, Jesus knew that everyone needed to know about God and His love. So after dinner He told a story to help those leaders think about how much God loves every single person!

The story was about a father with two sons. The father loved both of his sons very much. He planned to divide his money between his sons when they were older, according to the custom of that land. But the younger son didn't want to wait for his share of the money. (Choose a volunteer to play the part of the younger son.)

"I want my money right NOW, Dad," the younger son said. He wanted the money so that he could leave home.

So the father gave the younger son his part of the money. The younger son told his dad good-bye, took his money and headed down the road to a faraway city. (Give sack of coins to volunteer, who walks in place, carrying the money.)

When the younger son arrived at the distant city, he spent his money VERY foolishly. He spent money on lots of parties and anything else he could think of to have a great time. (Set out party items and distribute snacks. Volunteer pretends to have a party.) And he had lots of new friends now! But what do you think happened after a while?

One day the younger son looked in his money bag. It was completely EMPTY! (Take sack of coins, empty it and return empty sack to volunteer.) And now his friends didn't come to see him anymore. The younger son was in big TROUBLE. He didn't have any money or a job or any food!

At last he found a job, but it wasn't a very good job. The son had to take care of pigs! (Give stuffed animal pig to volunteer.) And because he was SO HUNGRY all of the time, he was just about ready to eat the pigs' food!

One morning the hungry younger son thought, *I am starving to death while the people who work for my father have plenty of food to eat. I'm going to go back home. I'll tell my father I was wrong. I'll tell him I don't deserve to be treated like his son anymore. I'll ask my father if I can work for him as a servant.* So the younger son decided to stop trying to do things his own way. He decided that he was going HOME—even though he wasn't sure how his dad would feel about him! (Ask volunteer to walk in place with sad or nervous facial expression.)

Meanwhile, back at home, the father still missed his younger son very much. Day after day, the father patiently looked down the road, hoping to see his son. FINALLY, one day, he saw his son walking down the road! The father was SO EXCITED that he couldn't wait for his son to reach him. He RAN to meet his son! He was GLAD to see his son, and didn't even wait for his son to make the speech about being the servant. Instead, he told the servants to make a big party!

The father told other servants to bring his son some new clothes and sandals and a ring of his own. (*Put robe and ring on volunteer. Ask volunteer to show how the younger son may have felt now.*) The father had a BIG party to celebrate! The son was so glad he had come home. Even though he had disobeyed and done wrong things like being selfish and spending his money foolishly, his father still loved him and forgave him!

GOD'S WORD & ME

Jesus wanted people to know that God is like that father, and we ALL are like that son. We ALL disobey God when we lie, say mean things to our friends or act rudely to our parents. But God still loves us. He will forgive us when we admit to Him that we have disobeyed and ask Him to forgive us. Then He helps us change our actions. Those are good reasons to celebrate!



- **Which people does God love more, good people or sinners?** (Neither. God loves sinners just as much as He loves good people.)
- **What's another way God shows His love?** (God sent Jesus, who died to take the punishment for our sin. Because Jesus died and rose again, we can be forgiven and can join God's family.)
- Invite a child to read aloud 1 John 1:9. **What does this verse say God will do if we confess our sin?** (Forgive us.) **God is always ready to forgive our sins when we admit we have done wrong and ask Him to forgive us!**
- **Take a moment to think. Is there anything you need to ask God to forgive? Let's pray silently for a minute or two. God loves you. He wants to forgive you when you ask!** Pray, thanking God for His forgiveness and for sending Jesus to pay the penalty for our sins. Invite children interested in talking about joining God's family to meet with you after class (see page 12 for "Leading a Child to Christ").

GAME CENTER

FOR YOUNGER CHILDREN • LUKE 15:11-32

COLLECT

Bible, rhythm instrument (shaker, tambourine, drum, etc.).

DO

1. Children stand in a large circle and pretend to be monkeys.
2. Stand in the middle of the circle and play a rhythm instrument. "Monkeys" make monkey sounds and move around circle to the beat of the rhythm instrument, moving quickly when instrument is played quickly and slowing down when instrument is played slowly.
3. Repeat activity, with children pretending to be different rainforest animals (jaguars, parrots, fish, snakes, etc.).

TALK ABOUT

- We're having fun moving slowly and then quickly. In our Bible story today, a father was so glad to see his son that the Bible says the father ran to give him a hug. The father loved his son so much! God loves us even more!
- Sometimes we might do something wrong. We might say something mean or tell a lie. But God still loves us! When we are sorry for doing wrong, God will forgive us. What can we say to God when we've done something wrong? (I'm sorry.)
- The Bible says, "If we tell God we are sorry for our sin, He will forgive us." I'm glad to know that God forgives us. Let's say the names of our friends here today who God loves and forgives. Lead children in saying each others' names.
- Pray briefly, **Dear God, thank You for Your love. Thank You for forgiving us when we disobey You. In Jesus' name, amen.**

FOR OLDER CHILDREN

Children move across the room and back, instead of moving in a circle.

GOD'S WORD

"If we confess our sins, he is faithful and just and will forgive us our sins and purify us from all unrighteousness."
1 John 1:9

FOR YOUNGER CHILDREN:

"If we tell God we are sorry for our sin, he will forgive us."

GOD'S WORD & ME

When we've disobeyed God, if we ask for forgiveness, God's constant love is shown by His forgiveness.



GAME CENTER

FOR OLDER CHILDREN • LUKE 15:11-32

COLLECT

Bible, construction paper, scissors, marker, masking tape.

PREPARE

Trace around your feet on construction paper and cut out a total of 24 footprints. Print words from 1 John 1:9 on 12 footprints (combine shorter words) to make two sets of printed footprints. Use masking tape loops to attach footprints to floor in order, making two separate verse trails through the "rainforest." (For more than 16 children, make additional verse trails.)

DO

1. Divide group into two teams of no more than eight players each. Each team lines up behind a verse trail.
2. From your Bible, read 1 John 1:9 to children. All children say words of verse together as team members take turns stepping on foot prints. With each repeat, remove one footprint from each trail, until last player can follow the trail without reference to any footprints.
3. Play game again, with children taping footprints to floor to form trails.

TALK ABOUT

- Read 1 John 1:9 with children. **What are some of the important words in this verse? Why do you think they are important?**
- **What does the word "confess" mean?** (Say or tell something.) **When we confess what we've done wrong to God, what does He promise to do?**
- **How do kids your age usually feel when they've disobeyed God?** (Guilty. Sad. Worried. Afraid.) **God understands when we feel sad or guilty. Because God loves us so much, however, He promises to forgive us if we are sorry for doing wrong. God's love doesn't stop, even when we've done wrong.**
- **Think about a time you need to ask God's forgiveness. Right now, you can tell God you are sorry, and ask His help in obeying Him.** Lead children in prayer, allowing time for children to pray silently, and then closing the prayer time by thanking God for His love and forgiveness.

FOR YOUNGER CHILDREN

After a word has been removed, replace it and remove another word. You may also use the verse as simplified for younger children.

GOD'S WORD

"If we confess our sins, he is faithful and just and will forgive us our sins and purify us from all unrighteousness."
1 John 1:9

FOR YOUNGER CHILDREN:

"If we tell God we are sorry for our sin, he will forgive us."

GOD'S WORD & ME

When we've disobeyed God, if we ask for forgiveness, God's constant love is shown by His forgiveness.

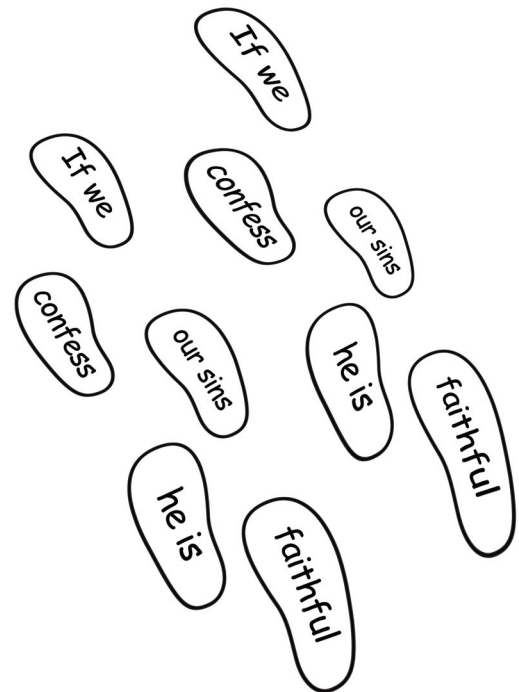

ART CENTER

FOR YOUNGER CHILDREN • LUKE 12:13-21

COLLECT

Bible, small and large construction paper in a variety of colors, scissors, tape, markers, stickers, adhesive craft foam shapes; optional—cardboard tubes for flag handles.

PREPARE

Roll and tape large sheets of paper as shown in sketch a. Make one for each child. Cut some small sheets of paper into triangle shapes. Make a sample flag following directions below.

DO

1. Show your flag to children. **The heart on this flag reminds me that God loves me.** Each child chooses a flag.
2. Child draws one or more heart shapes and writes his or her name on flag. (Be ready to draw hearts and write names if needed.) Children decorate flags by drawing with markers and attaching stickers and craft foam shapes.
3. Help each child tape edge of flag to a handle. Children hold flags high as they march around the room.

TALK ABOUT

- I'm so glad to know that God loves and forgives me. The Bible says, "If we tell God we are sorry for our sin, He will forgive us." When I've disobeyed God and done something wrong, I can say "I'm sorry." God doesn't stop loving me; He forgives me!
- When we're playing with friends, we might disobey God by saying something mean, or not taking turns. But what can we say to God when we've disobeyed? ("I'm sorry.") When we say "I'm sorry" to God, He forgives us and helps us obey Him. Let's say thank-You to God. Lead children in a prayer of thanks to God for His love and forgiveness.
- Let's hold our flags high to show how glad we are that God loves us! Who would like to say "God loves me"? Lead children to repeat sentence with you. Repeat for "God forgives me."

FOR OLDER CHILDREN

Encourage children to design symbols representing God's love and forgiveness (open hand, heart pattern, gift labeled forgiveness, etc.) to draw on their flags.

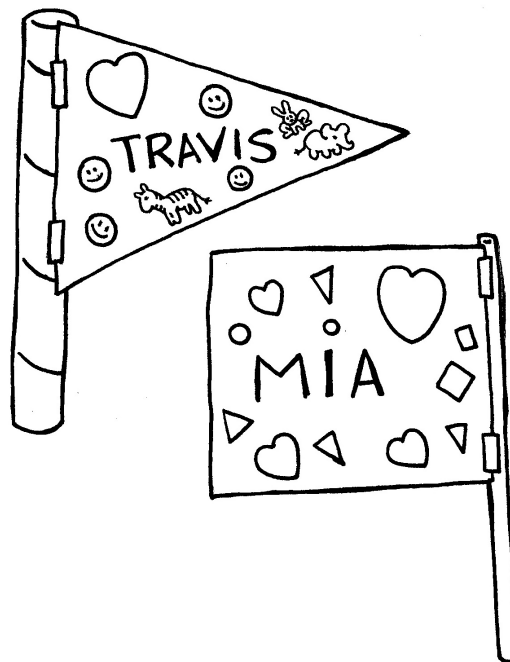
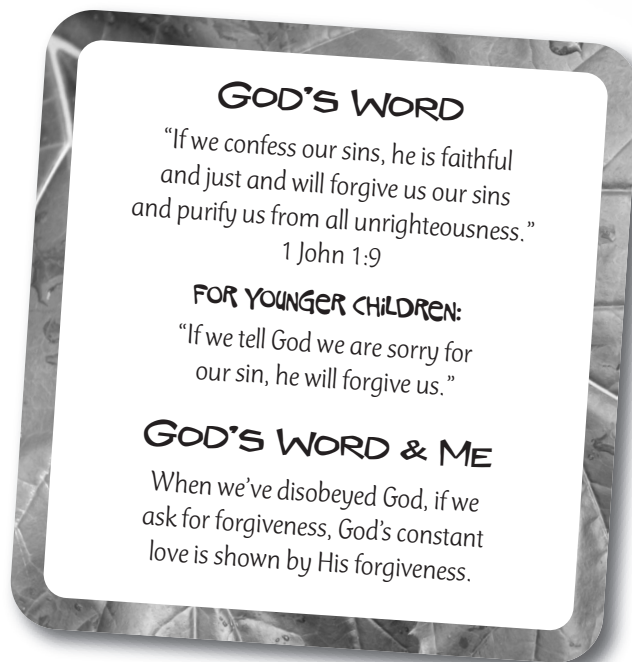

ART CENTER

FOR OLDER CHILDREN • LUKE 15:11-32

COLLECT

Bible, Lesson 11 Pattern Page (p. 196), clear Con-Tact® paper, card stock, scissors, paper, thin-tip markers.

PREPARE

Copy Lesson 11 Pattern Page onto card stock and cut apart the bookmarks, making enough copies so that children may choose which bookmark they want. Cut Con-Tact paper into strips slightly larger than bookmarks, making two strips for each child.

DO

1. Read 1 John 1:9 and ask children to say this verse in their own words. Then show the bookmark choices from the Lesson 11 Pattern Page. Each child chooses a bookmark.
2. Child uses markers to color in the bookmark design. (Children may draw their own decorations and pictures on the other side of the bookmark.)
3. Help each child peel backing off of Con-Tact paper strip, place decorated bookmark onto Con-Tact paper and then cover with second Con-Tact paper strip.
4. Children take home bookmarks to mark 1 John 1:9 in their Bibles as reminders of God's promise of forgiveness.

TALK ABOUT

- **Why is it so important for people to know about asking God's forgiveness?** (God's forgiveness makes it possible for us to join God's family. God's forgiveness helps us stop feeling sad because of our sin and wrong actions.) **What does God promise to do when we say we're sorry for our wrong actions?**
- **What would you say to explain what it means to be forgiven by God?** (Being forgiven by God means that we can know He always loves us. It means that God doesn't give up on us when we do something wrong.) **What is an example of a time a kid your age needs to ask forgiveness from God?**
- **How does God help us after we've sinned?** (He listens to us when we pray. He forgives us. He will help us obey Him, instead of doing wrong.) Pray, thanking God for His love and forgiveness.

FOR YOUNGER CHILDREN

Unless you have an adequate number of helpers, do not cover bookmarks with Con-Tact paper.

GOD'S WORD

"If we confess our sins, he is faithful and just and will forgive us our sins and purify us from all unrighteousness."

1 John 1:9

FOR YOUNGER CHILDREN:

"If we tell God we are sorry for our sin, he will forgive us."

GOD'S WORD & ME

When we've disobeyed God, if we ask for forgiveness, God's constant love is shown by His forgiveness.



WORSHIP CENTER

Luke 15:11-32

COLLECT

Bibles, *Parable Quest* CD-ROM and CD player, song charts (pp. 249, 251), large sheet of paper, marker.

PREPARATION

Print 1 John 1:9 on large sheet of paper. Prepare questions to help children guess words of the verse (see suggestions below). Use a Post-it Note to mark Psalm 145:1-3 in a Bible.

Team Game

Children play a game like Knots. Help children form circles with no more than eight children in each circle. Have each child hold up his or her right hand, and then grasp the right hand of the person across from him or her in the circle. Then each child uses left hand to grasp the left hand of someone else in the circle, representing a twisted rain-forest vine. At your signal, "vines" try to untangle themselves as much as possible without letting go of each others' hands. Repeat as time permits.

BIBLE VERSE GAME

Display 1 John 1:9 for children and read it aloud with them. Then lead children to play a guessing game in which they try to identify words of the verse in response to your questions. (When children catch on to how the game is played, allow them to think of the questions.) As words are guessed, have a child circle or underline the word on the paper. Ask, **Which two-letter word refers to God?** (He.) **Which two-letter word refers to all of us?** (We.) **Which word means the same as "fair?"** (Just.) **Which word starts with the letter F and tells what God will do?** (Forgive.) **Which four-letter word refers to the ways we disobey God?** (Sins.) **What is the longest word in this verse?** (Unrighteousness.)

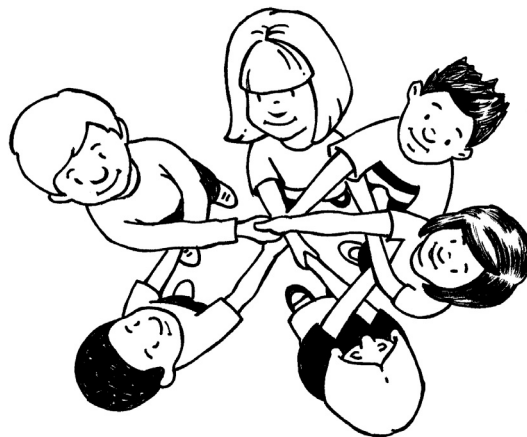

GOD'S WORD

"If we confess our sins, he is faithful and just and will forgive us our sins and purify us from all unrighteousness."
1 John 1:9

FOR YOUNGER CHILDREN:

"If we tell God we are sorry for our sin, he will forgive us."

GOD'S WORD & ME

When we've disobeyed God, if we ask for forgiveness, God's constant love is shown by His forgiveness.

SONG

You, or another leader, lead children in singing "God Forgives Us," adding motions and/or clapping if desired.

PRAYER

Listen to these words that tell us about God's amazing love and forgiveness. Have a child who is a good reader read aloud Psalm 145:1-3 from the Bible you marked. Then invite all children to repeat in unison, "Thank You, God, for Your love and forgiveness."

SONG

You, or another leader, lead children in singing "Call Upon Me," adding motions and/or clapping if desired.

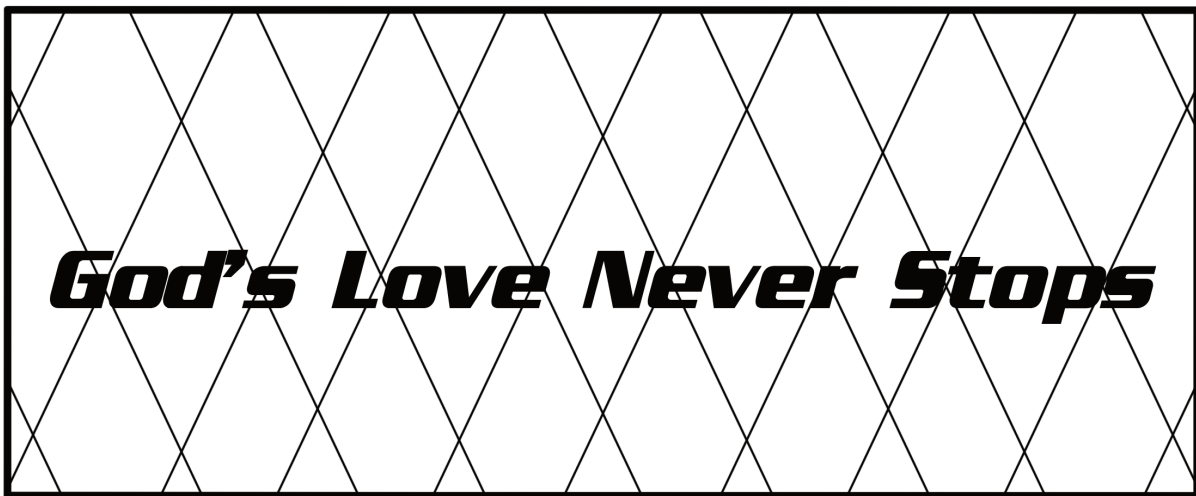

Jesus tells about a loving father.

Luke 15:11-32



What can we say to God when we've disobeyed Him? God will love us and forgive us.

a STEP IN THE RIGHT DIRECTION!

Help the lost boy get home—and discover an important message!

Starting at “I,” collect every other letter. When you get to the pigpen, turn around! Start with “A” to collect every other letter. As you go, write down every letter. Then draw lines to separate the words!

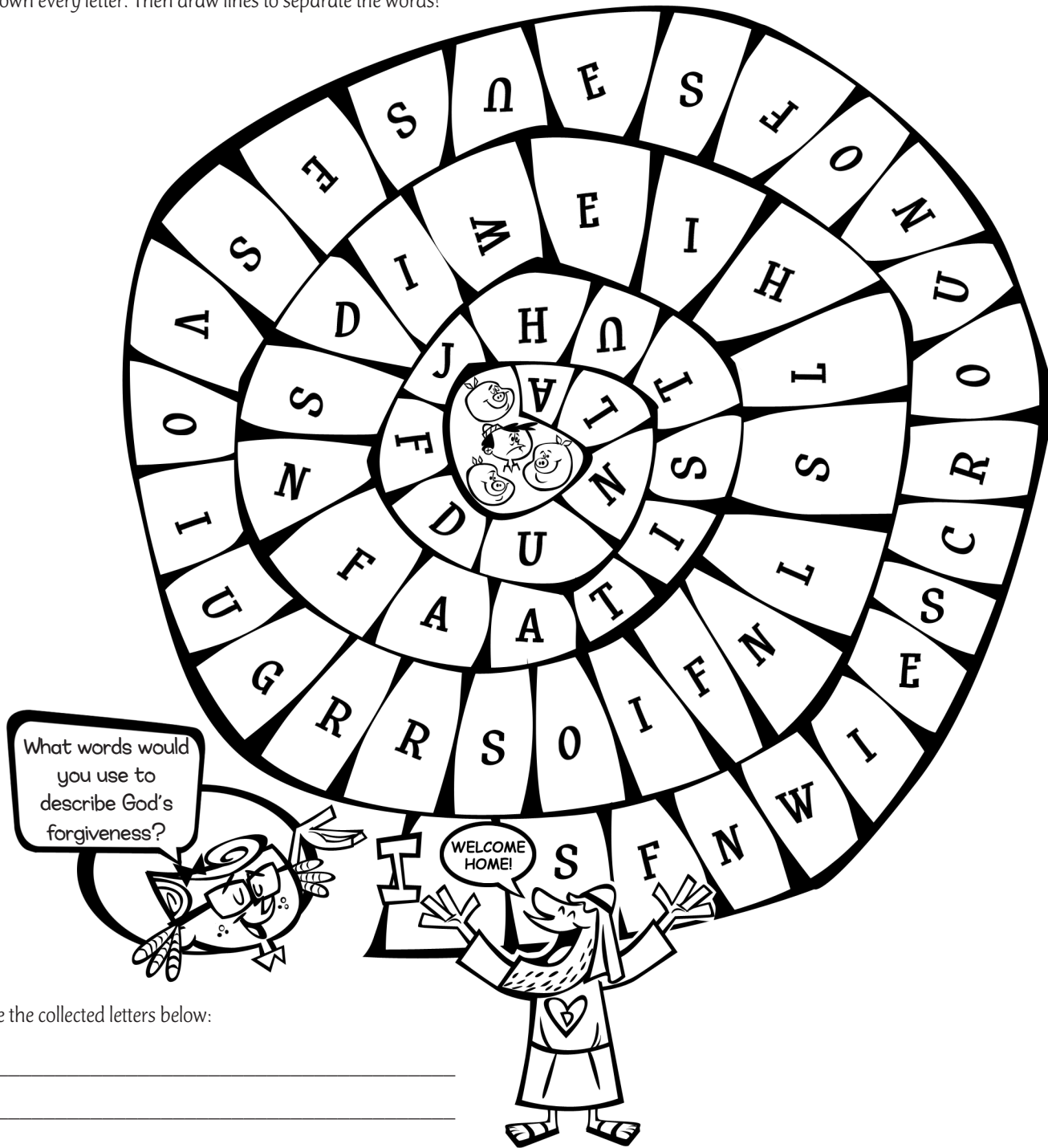

Write the collected letters below:

PHARISEE AND TAX COLLECTOR

LUKE 18:9-14



Teacher's Devotional

When have you heard anyone define humility? Humility can be easily misunderstood. Humility is more than the opposite of “me at the center” thinking. And it’s beyond an attitude of “I don’t really matter”—that’s still a sad self-focus. It is also not a self-conscious goodness that says, “Look at me! See how humble I am!” Humility is beyond all of this: It is the complete forgetting of self that happens when one is focused on a bigger agenda than me.

Does this make humility sound dull? Don’t be fooled—it’s one of the “secret weapons” of the Kingdom of God! Humble people are so focused on Jesus and others that they forget themselves. That’s ground for astounding change! Others’ lives and hearts are nurtured and God’s power is shown. Like a huge wave, untraceable in its origin, humility creates a powerful movement that can’t be stopped!

Respecting each and every person as if he or she were Jesus is a good place to begin understanding humility. (Imagine what our lives would be like if we lived as if every single person we met had infinite value to God!) In pursuing this sort of humility and self-forgetting love, resist the temptation to congratulate yourself or think that you deserve recognition for your good attitude: Remember that the original example of humility is Jesus. He humbled Himself far more than you will ever have to—so He could redeem all creation, including you!

GOD’S WORD

“Be completely humble and gentle; be patient, bearing with one another in love.”
Ephesians 4:2

FOR YOUNGER CHILDREN:

“Be patient and show love to each other.”

GOD’S WORD & ME

Show respect to others and be humble and patient in the way you treat them because God values each person.

PLANNING PAGE

Choose which centers you will provide and the order in which children will participate in them (see pp. 14-18 for schedule tips and pp. 24-25 for guidelines in combining older and younger children). Also plan who will lead each center (for staffing tips see pp. 19-21). Use the reproducible planning sheet (p. 238) to record your plans.

BIBLE STORY CENTER

BIBLE STORY

Pharisee and Tax Collector • Luke 18:9-14

ADVENTURE BOX (YOUNGER CHILD)

Use props (wooden or cardboard blocks and two toy people) to demonstrate story action

ADVENTURE BOX (OLDER CHILD)

Wear costumes (two Bible-times costumes or headdresses [fabric squares and cloth strips]) and dramatically tell and pantomime the story

ART CENTER

YOUNGER CHILD OPTION

Make and decorate a paper chain of people and talk about ways to show patience and help to the pictured people

MATERIALS

Bible, Lesson 12 Pattern Page (p. 210), scissors, crayons or markers, tape

OLDER CHILD OPTION

Make collages with words and/or pictures about showing respect and humility and talk about ways of being humble

MATERIALS

Bible, black and/or dark blue construction paper, discarded magazines and catalogs, scissors, glue sticks

GAME CENTER

YOUNGER CHILD OPTION

Play a game to jump into a "canoe" and talk about ways of showing help and patience to each other

MATERIALS

Bible, *Parable Quest* CD-ROM and CD player, several large towels or sheets

OLDER CHILD OPTION

Help each other cross a "river" and talk about ways to show respect and love to others

MATERIALS

Bible; masking tape or rope; for each team—two squares of heavy cloth or carpet samples large enough for two children to stand on

COLORING/PUZZLE CENTER

YOUNGER CHILD OPTION

Review the Bible story while completing coloring page

MATERIALS

Lesson 12 Coloring Page (p. 211) for each child, crayons

OLDER CHILD OPTION

Review Ephesians 4:2 while completing puzzle page

MATERIALS

Lesson 12 Puzzle Page (p. 212) for each child, pencils

WORSHIP CENTER

FOR THE YOUNGER AND OLDER CHILD

Participate in large-group activities to review Bible verse and to worship God together

MATERIALS

Bibles, *Parable Quest* CD-ROM and CD player, song charts (pp. 252-253), at least six inflated balloons, three or four beanbags

BONUS THEME IDEAS

Bonus Theme Ideas can be used at any time during this session: as an additional activity center, to extend the session for a longer time, or for added theme excitement.

RAINFOREST ANIMAL SHOW

Ahead of time, invite children to bring any stuffed rainforest animal (parrot, jaguar, snake, fish, monkey, frog, leopard). Display animals in a central area. Give each animal an award (Most Colorful, Best Looking, Friendliest, Softest, Scariest, Funniest, etc.).

Post a note alerting parents to the use of food. Also, check registration forms for possible food allergies.



JAGUAR PAW PRINTS

Set out small bowls in which you have placed soft cream cheese or white frosting. Give each child a plastic knife, paper plate, four small round crackers (such as oyster crackers or Ritz Bits) and one rice cake. Children spread cream cheese or frosting on rice cakes and then place small crackers on each rice cake to form a paw print.

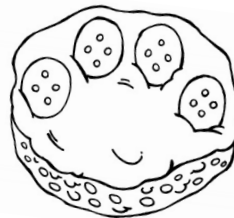

DART FROG SUCTION CUPS

Collect several suction cups (available at craft stores for hanging crafts on windows). Explain to children, **The strawberry dart frog lives in the rainforest. They have suction cups on their feet so they can hang on to wet trees and slippery leaves. Let's try an experiment with suction cups and find out what they will stick to.** Invite children to push suction cups onto tabletop and try pull up the cups. Repeat with other available surfaces (windows, asphalt, cement, paper, carpet, plastic, books, etc.).

BIBLE STORY CENTER

FOR YOUNGER CHILDREN • LUKE 18:9-14

INTRODUCTION

Welcome your rainforest explorers by saying, **Let's pretend we are jumping over a river in the rainforest.** Have children stand up and first pretend they are jumping over a very small river. For each round, tell children the river is getting bigger. (Optional: Set out two lengths of yarn to represent the river. Widen the distance between the yarn for each round of the game.) Then show Adventure Box. **What do you think is in our Adventure Box today? Let's find out!** Untie box. Remove items from box and use them to demonstrate story action as you tell the story.



ADVENTURE BOX

In a cardboard or wooden box labeled "Adventure," place a Bible, wooden or cardboard blocks and two toy people. Tie rope or brown yarn around the box or crate.

TELL THE STORY

One day Jesus told a story about two men who went to the Temple to pray. (Use blocks to build Temple. Place toy people near building. Move each toy person when they are being described or when they are speaking.)

One man who went to God's Temple to pray was a religious leader. He was very proud of the way he followed God's laws and rules. He was called a Pharisee.

The other man was a tax collector. People didn't like the tax collector very much. Tax collectors often took more money from people than they were supposed to. No one liked that. So they didn't have many friends!

The Pharisee stood up to pray, where everyone could see him. He said, "God, I thank You that I am not like *other* men. I am not a thief or a bad person. I don't do bad things. Besides, I do many good things!" The Pharisee looked around the Temple and saw the tax collector. "Thank You, God, that I am not like that sinful tax collector!" People in the Temple must have seen the Pharisee, standing proudly. They must have heard the Pharisee, bragging to God about how good he was!

The tax collector stood quietly, off by himself. He was praying, too. But his prayer was very different. He bowed his head low. He didn't want people to see him. He only wanted God to see him. He prayed, "God, please have mercy on me. I am a sinner." The tax collector knew he didn't do things right. He didn't think he should get anything good from God. He knew that the only way he would have God's forgiveness was if God was kind to him!

Jesus said, "God forgave the tax collector. But God did not forgive the Pharisee." The Pharisee was proud. He thought he was better than other people because he followed lots of rules. But the tax collector knew he wasn't better than anyone else. He was sorry for his sins. He knew only God's love could help him."

Jesus wanted people to know that everyone needs God's forgiveness. God wants us to be like the tax collector, not like the Pharisee! Even though the tax collector had done wrong things, he didn't think he was better than other people.

GOD'S WORD & ME

Sometimes we think we are smarter or better than some other people. But God's Word says that God loves us all the same. God loves each person so much! And because God loves each of us, He wants us to love each other. The Bible says, "Be patient and show each other love, because God loves us." Pray, **Dear God, please help us to be patient and show love. Thank You for loving us. In Jesus' name, amen.**



BIBLE STORY CENTER

FOR OLDER CHILDREN • LUKE 18:9-14

INTRODUCTION

Let's play opposites. Whatever action I say, do the opposite. Give commands (stand up, sit down, nod your head, pat your left shoulder, reach up, etc.). End by saying, **Stand up and talk.** (Children should sit down silently!) **Today, we're going to hear a story Jesus told about opposites. He told about a man who was the opposite of proud. What would that be?** (Humble.)

What do you think is in our Adventure Box today? Let's find out! Untie box. Remove items from box. Have two adult helpers ready to put on costumes and dramatically pantomime story action as you tell the story. (Optional: Wear a costume yourself and act out the story.)

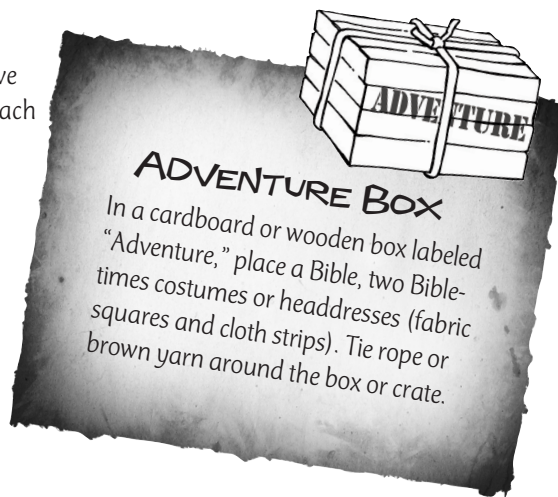

TELL THE STORY

Jesus spent time with a lot of different people. One time, Jesus was with some people who were very confident that they were better than other people. They believed they were more righteous, or did more good things and fewer bad things, than other people they knew. They really looked down on everyone else.

Of course, Jesus knew what they were thinking and feeling. So he told them this story about two men who went to the Temple to pray—and what God thought of their prayers!

Jesus told about one man who came confidently into the Temple. This man was a Pharisee, a religious leader who was very proud of the way he followed God's laws and rules. He was sure that he was better than anyone else!

The other man was a tax collector. People didn't like tax collectors very much! Many tax collectors took more money from people than they were supposed to. So this tax collector may have had lots of money but he probably didn't have any friends.

Jesus said that once these two were in the Temple, each one began to pray. The Pharisee stood up to pray. He wanted to make sure people saw him praying. He prayed loudly, "God, I thank You that I am not like other men—those robbers and evildoers—or even like that tax collector over there! I never do anything wrong. Besides that, I do many good things! I give some of everything I get to You, God. And twice a week, I don't eat. Instead, I spend extra time worshiping You, God!" The other people in the Temple must have heard the Pharisee thanking God that he was such a good man! (Do you think it sounded a little like bragging?)

Now, the tax collector had come to the Temple to pray, too. But he didn't stand in the middle of the courtyard and pray loudly. He wasn't interested in impressing people. No, his prayer was very different. He bowed his head low and prayed, "God, please have mercy on me. I am a sinner." The tax collector knew he didn't do things right. He didn't think he should get anything good from God. He knew that the only way he would have God's forgiveness was if God was kind to him! He was humble and didn't think he was better than anyone else!

Jesus told the people listening, "I tell you, it was the tax collector who received God's forgiveness! But God did not forgive the Pharisee—after all, he didn't even think he needed to be forgiven! He thought he was better than others. But the tax collector knew he wasn't better than anyone else. He was humble and sorry for his sins."

Jesus went on to say that people who are proud of themselves in front of God, who say to everyone, "Look at how good I am!" will find out that they are not so good. God will show them where they are wrong. And people who know they are not better than others will be helped and blessed by God.

Jesus wanted these people to know that everyone needs God's forgiveness.

GOD'S WORD & ME

Everyone thought of the Pharisee as being more holy and more important than a tax collector. But God values and loves every person. He wants us to show respect and humility to each other because He cares about every person! In God's eyes we're all valuable and important.

- **What are reasons some kids might think they are better than others?** (Rich. Have new toys. Are popular. Get good grades. Good at sports.)
- **How do kids act when they think they are better than others?** (Brag about themselves. Make fun of others. Act unfriendly.)
- **How would you define the word "humble?"** (To think about the needs of others. To care for others and be patient with them. To remember that God loves everyone.)
- Invite a child to read aloud Ephesians 4:2. **Think about one way you can obey this verse today.** Tell children your own plan for obeying the verse. Pray with children, asking God's help to be humble and to treat others with respect, because God values each person.



GAME CENTER

FOR YOUNGER CHILDREN • LUKE 18:9-14

COLLECT

Bible, *Parable Quest* CD-ROM and CD player, several large towels or sheets.

PREPARE

In open playing area, set out towels or sheets to represent canoes.

DO

1. While "Love Never Fails" plays, children pretend they are walking in the rainforest. From time to time, stop the music and call out, "To the canoes!" Children move quickly to the nearest canoe and jump into it. Encourage them to show patience and kindness to each other as they make sure each child has a place in a canoe.
2. Point to each canoe and give children a different action to do (paddle the canoe, look through binoculars, take a photograph, look up and point to a bird, make the sound of a rainforest animal such as a monkey or jaguar, etc.). Continue, assigning different actions each time.

TALK ABOUT

• I saw our friends here today helping each other get into the canoes. Helping each other is a way to be patient. When we play games, we can be patient and help each other. What are some games you like to play with your friends? How can you be patient and help your friend when you play with (cars and trucks)? (Take turns. Be careful when playing with someone's toys.)

• The Bible says, "Be patient and show love to each other." Who are some of your friends? How are your friends patient with you? (Help me clean up toys. Wait for me to finish a snack before starting to play.) What can you do to be patient with them? (Listen when they talk. Wait for them to have a turn on the slide.)

• When we are patient with others, it shows that we are remembering that God loves them. Pray briefly, Dear God, thank You for loving each person. Please help us to be patient and loving, too. In Jesus' name, amen.

FOR OLDER CHILDREN

Instead of assigning actions to children after they gather in a canoe, children in each canoe say words of Ephesians 4:2, either in unison or taking turns to say one word of the verse in order. For an extra challenge, each round of the game remove a towel or sheet or fold it smaller to see if children can patiently help each other fit in each canoe.

GOD'S WORD

"Be completely humble and gentle; be patient, bearing with one another in love."
Ephesians 4:2

FOR YOUNGER CHILDREN:

"Be patient and show love to each other."

GOD'S WORD & ME

Show respect to others and be humble and patient in the way you treat them because God values each person.

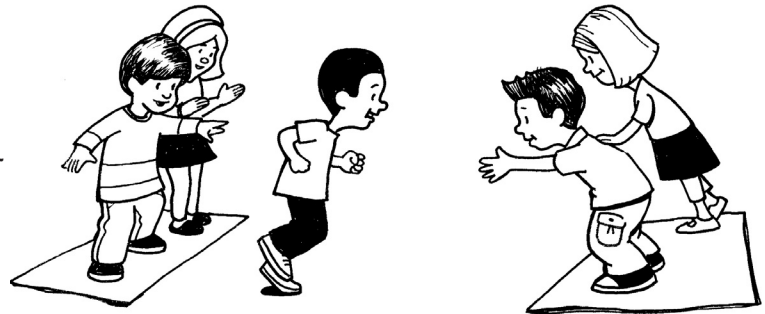

GAME CENTER

FOR OLDER CHILDREN • LUKE 18:9-14

COLLECT

Bible; masking tape or rope; for each team—two squares of heavy cloth or carpet samples large enough for two children to stand on.

PREPARE

Use masking tape or rope to mark a starting line at one end of playing area and a finish line approximately 30 feet (9 m) away to represent a rainforest river.

DO

1. Divide group into teams of six to eight players. Teams line up behind starting line. Give the first player on each team two squares of cloth or carpet representing stepping stones.
2. At your signal, the first player on each team places one square on the ground in front of him or her and then jumps onto it. Player places second square on the ground in front of him or her and then jumps onto it. Second player on each team jumps onto the first square and then onto the second square, reaches back, picks up the first square and hands it to the first player. First player places square on ground in front of him or her and then jumps onto it. Players repeat procedure until they reach the finish line. Then players pick up squares and run back to team, passing squares to the next players.
3. Game continues in relay fashion until each player has had a turn.

TALK ABOUT

- **In this game, two players needed to be patient and helpful in order to finish the relay. What are some times at your house or in your neighborhood that people need to be patient?** (When you're waiting to play a computer game. When you need someone's help to do homework.)
- Read Ephesians 4:2 aloud to children. **This verse talks about ways to show respect to others. Why do you think it is important for kids to show respect to each other?** (When kids are respectful, it helps them get along. It's a good way to make and keep friends.)
- **What might someone say or do to show that he or she is humble?** (Not brag about themselves. Compliment someone else.) **Gentle?** (Say nice things about others. Use words instead of actions when angry.)
- **Think about someone who has shown respect to you. Now think about someone to whom you can show respect.** Lead children in prayer, allowing time for them to silently thank God for people who show respect, and asking His help in showing respect. Close the prayer time by thanking God that He loves each person and that He will help us show His love to others.

FOR YOUNGER CHILDREN

Shorten the length of the rainforest river. Demonstrate how to use the squares as stepping stones, but cross the river by yourself, not with a partner. Each child takes a turn.

GOD'S WORD

"Be completely humble and gentle; be patient, bearing with one another in love."
Ephesians 4:2

FOR YOUNGER CHILDREN:

"Be patient and show love to each other."

GOD'S WORD & ME

Show respect to others and be humble and patient in the way you treat them because God values each person.

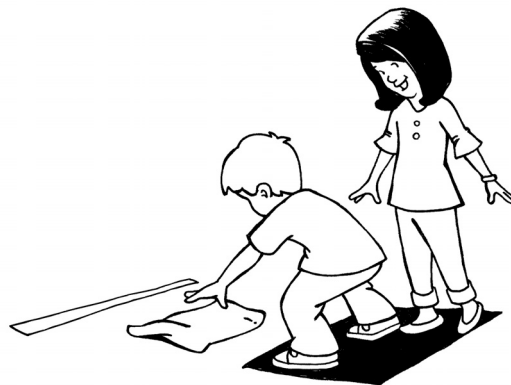

ART CENTER

FOR YOUNGER CHILDREN • LUKE 18:9-14

COLLECT

Bible, Lesson 12 Pattern Page (p. 210), scissors, crayons or markers, tape.

PREPARE

Make a copy of the Lesson 12 Pattern Page for each child. Cut out the person shape. (Optional: Make an additional copy for each child.)

DO

1. Help children make a paper chain of people. Give each child a person shape. Child colors the shape, adding facial and clothing details, to look like someone to whom he or she can show patience. (Optional: Child makes a second person shape, coloring it to look like him- or herself.)
2. Collect finished shapes. Tape them together at hands to form a chain of people. Display chain in your room.

TALK ABOUT

- The Bible says, “Be patient and show love to each other.” When we are patient, it means we know how to wait to have a turn or to do something. We are making pictures of people we can be patient with. Who are you making a picture of?
- We can also be patient when we help someone. Who is someone you help? What do you do to be patient and help (your brother)? (I wait for him to finish playing a game. I wait for my mom to cook my breakfast.)
- Let’s pray and ask God’s help in being patient. When I pray, you can say the name of a person you will be patient to. Dear God, thank You for loving each one of us. Please help us to be patient with (pause to allow children to say names aloud). In Jesus’ name, amen.

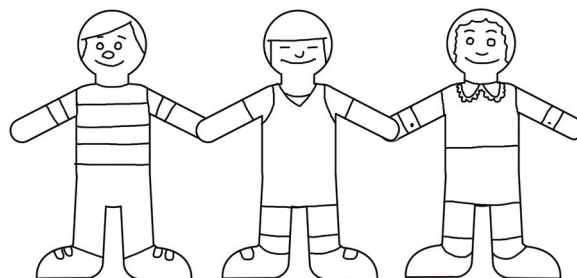

GOD’S WORD

“Be completely humble and gentle; be patient, bearing with one another in love.”
Ephesians 4:2

FOR YOUNGER CHILDREN:

“Be patient and show love to each other.”

GOD’S WORD & ME

Show respect to others and be humble and patient in the way you treat them because God values each person.

FOR OLDER CHILDREN

Children cut out people shapes themselves. Provide additional paper. Children cut out conversation balloons and write words in the balloons to show what someone might say to be patient and show respect to others.

ART CENTER

FOR OLDER CHILDREN • LUKE 18:9-14

COLLECT

Bible, black and/or dark blue construction paper, discarded magazines and catalogs, scissors, glue sticks.

PREPARE

Make a sample collage for the phrase “Be Humble” following instructions below.

DO

1. Show the collage you made, and talk with children about what it means to show respect and be humble.
2. Read Ephesians 4:2 aloud and lead children to brainstorm additional phrases and pictures that would illustrate actions of respect and humility. Each child chooses a phrase and/or picture.
3. Give each child a sheet of construction paper. Set out discarded magazines and catalogs. Children make collages by cutting large letters, words and/or pictures from magazines and gluing cut-outs to paper. Children may also add decorations and designs.

TALK ABOUT

• How would you define the word “humble”? Who is someone you know who is humble? What does the person do? What is someone like who is not humble?

• Read Ephesians 4:2 aloud. What is the main idea of this verse? How would you say the main idea in two or three words?

• What difference would it make in your family if everyone showed respect for others in the ways described in Ephesians 4:2? What difference would it make in our city? Lead children in prayer, asking God’s help in making a difference in people’s lives by treating them with respect and humility.

FOR YOUNGER CHILDREN

Precut faces of people from magazines and catalogs. Children choose faces and glue them to paper to make collages. Talk with children about ways to show patience to others.

GOD’S WORD

“Be completely humble and gentle; be patient, bearing with one another in love.”
Ephesians 4:2

FOR YOUNGER CHILDREN:

“Be patient and show love to each other.”

GOD’S WORD & ME

Show respect to others and be humble and patient in the way you treat them because God values each person.



WORSHIP CENTER

LUKE 18:9-14

COLLECT

Bibles, *Parable Quest* CD-ROM and CD player, song charts (pp. 252-253), at least six inflated balloons, three or four beanbags.

TEAM GAME

Children sit on the floor in a group. **In the rainforest, some animals live high in the trees, called the canopy layer of the rainforest. Let's see if we can keep these balloons up in the "canopy."** Toss a balloon to the group. Children bat the balloon as high as possible, trying to keep it from hitting the floor. (Optional: Children spread out, lie down on their backs and use their feet to hit the balloons up in the air.) After 10 seconds, toss out another balloon. Continue until all balloons are in play. End the game by calling out "Freeze." Children catch balloons. Play again, challenging children to see if they can keep the balloons from landing on the "rainforest floor."

BIBLE VERSE GAME

Repeat Ephesians 4:2 aloud with children. Then invite several volunteers to stand in front of group with their backs to the group. Give each volunteer a beanbag. Call out the Bible verse reference as a signal to volunteers to gently toss beanbags over their shoulders. Children who catch beanbags repeat the words of Ephesians 4:2 in unison. Repeat as time permits, with different children tossing the beanbags.

SONG

You, or another leader, lead children in singing "Love Never Fails," adding motions and/or clapping if desired.

PRAYER

Think of what you'll be doing after you leave church today. Think of the people you will be with. When you've thought of someone, clap your hands three times. Demonstrate action, and pause to let children respond. **Now think of one way you can show respect and be patient with that person. When you've thought of a way, clap your hands three times again.** After pausing to let children respond, lead children in prayer, asking God's help in showing His love to others.

SONG

You, or another leader, lead children in singing "Salt," adding motions and/or clapping if desired.

GOD'S WORD

"Be completely humble and gentle; be patient, bearing with one another in love."
Ephesians 4:2

FOR YOUNGER CHILDREN:

"Be patient and show love to each other."

GOD'S WORD & ME

Show respect to others and be humble and patient in the way you treat them because God values each person.



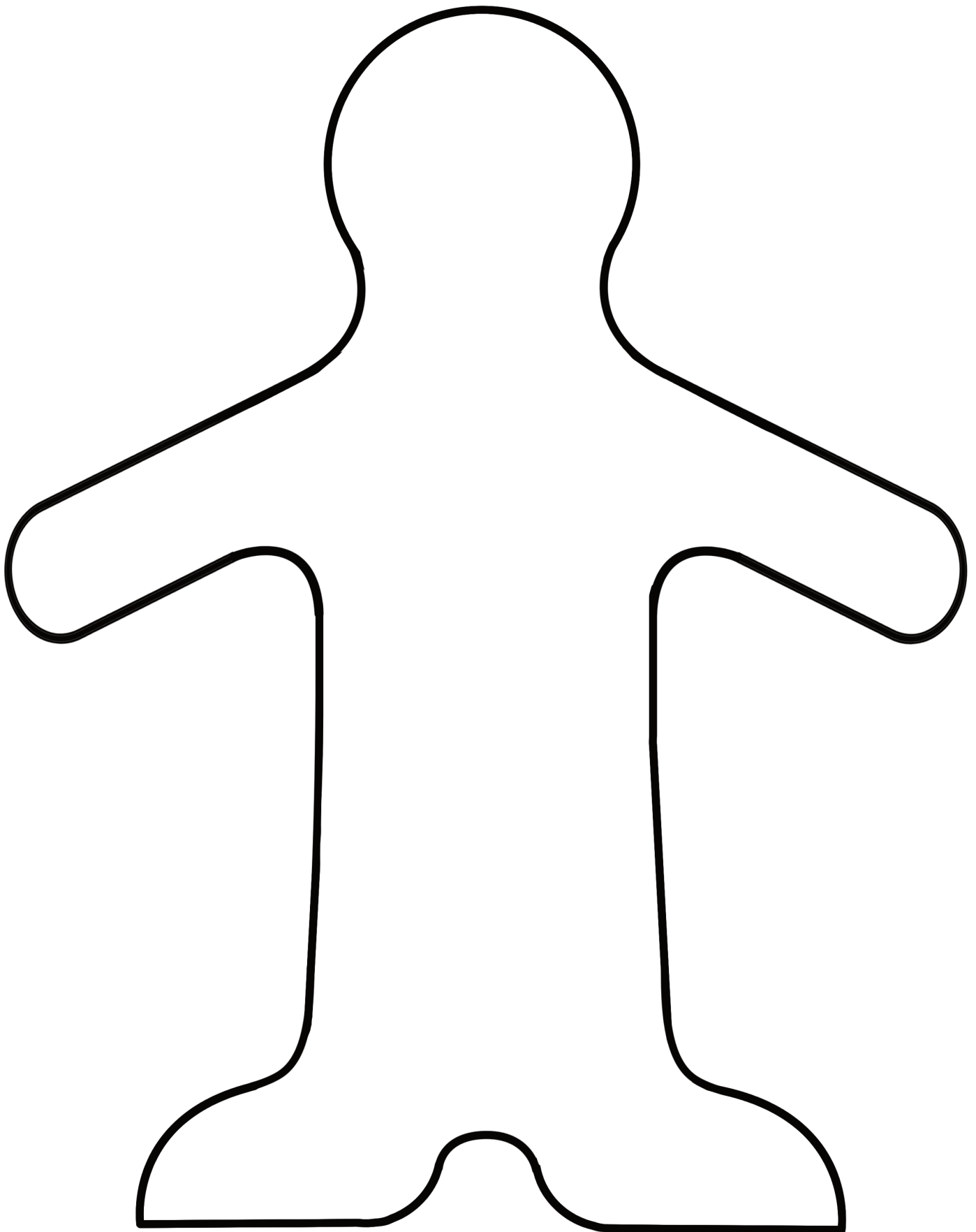

Two men pray.
Luke 18:9-14

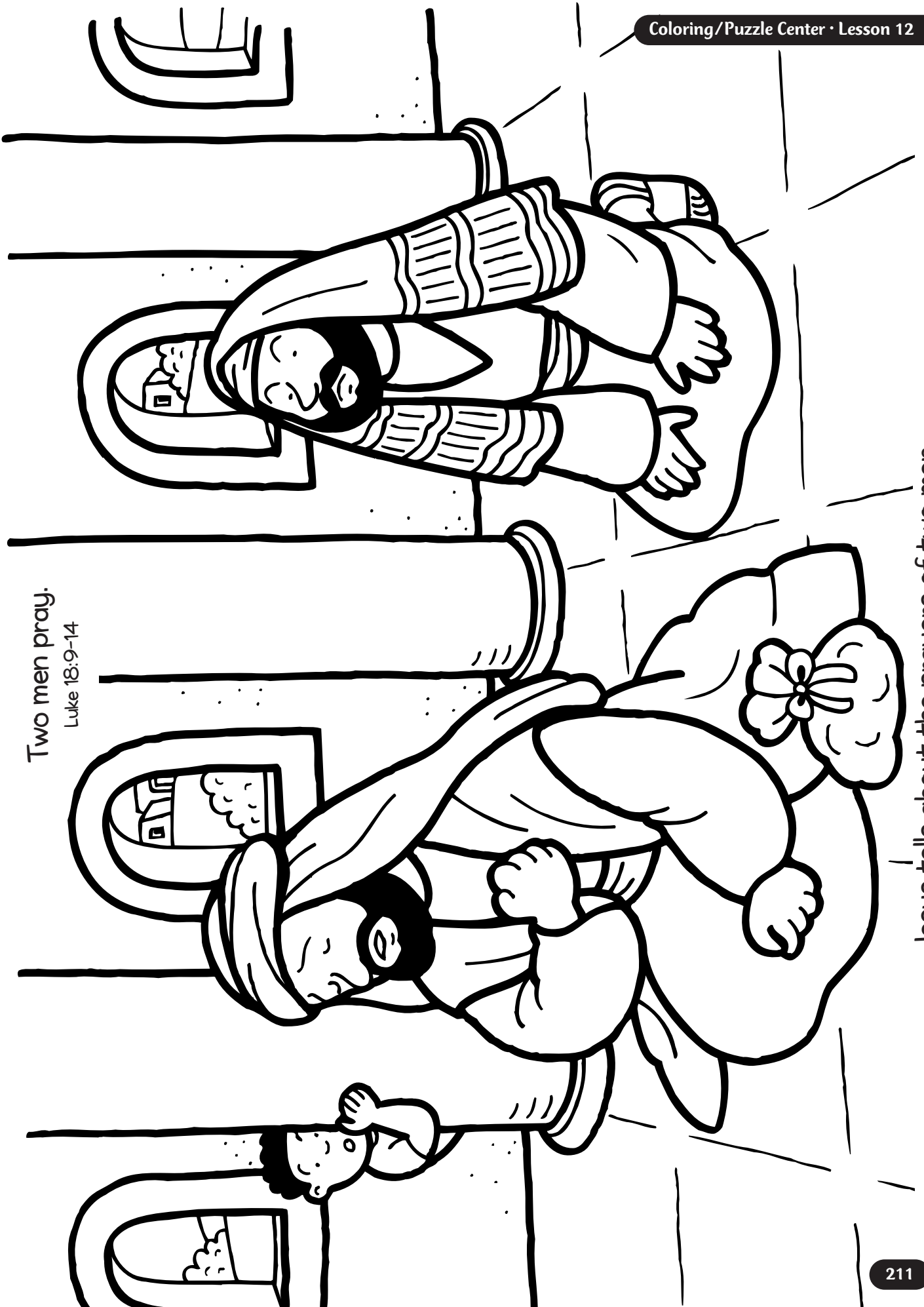

Jesus tells about the prayers of two men.
When can you pray to God?

RHYME TIME

Do each letter equation below. Then fill in the blanks in order to complete the poem!

- s+prince-pr = _____
- valley-ley+ues = _____
- eager-ger+child-ild = _____
- helper-hel+son = _____
- sea-a+e = _____
- re+inspect-in+ful = _____
- w+hat = _____
- shoulder-er = _____
- bee-e = _____
- life-l-e = _____
- gentleman-man = _____

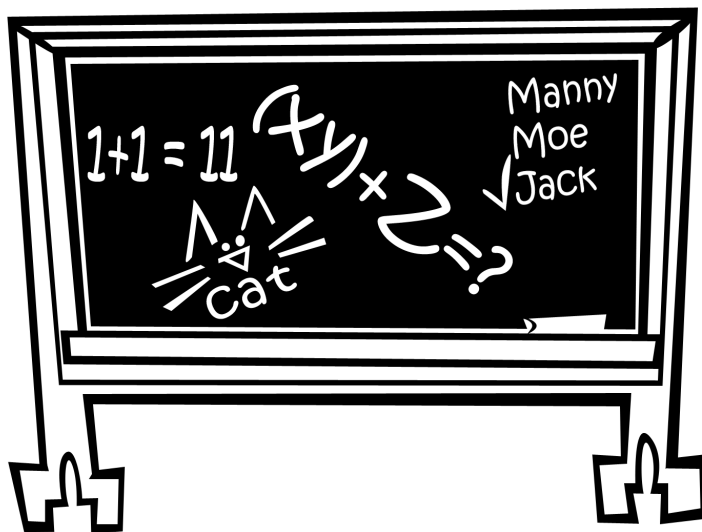

- kindergarten-ergarten = _____
- remind-re = _____
- fraction-r-ion = _____
- simple-sim+asked-k = _____

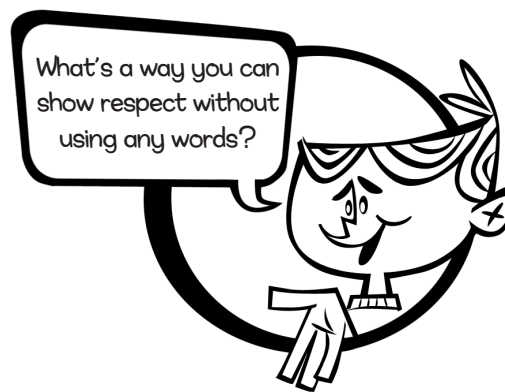
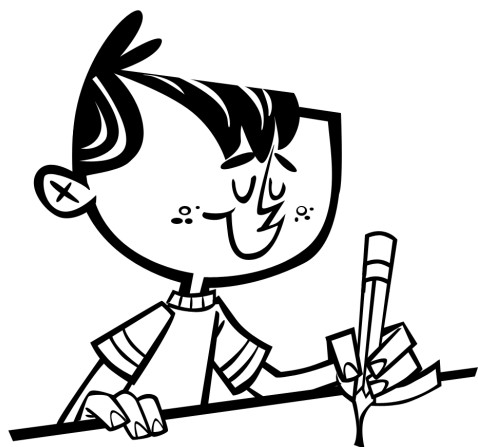

What's a way you can show respect without using any words?

_____ God _____ we _____,
 _____ is _____ we _____.
 _____ we're _____ and _____, God really won't _____
 In _____, He'll be _____ as can be!

Talents

MATTHEW 25:14-30



**USE YOUR
GIFTS**

Teacher's Devotional

What's one thing you would change about yourself if you could? Have you ever thought that a characteristic which you don't like might actually be a gift God has given you? When Amy Carmichael was a young girl, she was the only one in her family with brown eyes. This disturbed her greatly! She even prayed for God to change her eye color. But years later, God had called her to India. She was saving children from temple prostitution and providing them a home. She realized then how much more quickly accepted, how much more easily connected she was to these children, because of her brown eyes—the very thing she'd wanted God to change.

In the same way, God has gifted each of us with gifts we might not recognize—or gifts that we trivialize because they aren't valued by others. But think again as you re-read the parable of the talents. Take some time to list your own characteristics, ways you relate to others, abilities you've developed. Write out a second column beside this list of the ways God has used those things to build His Kingdom and do His work through you. (The fact that you're even reading this means you've been willing to use the gifts God has given you!) Let the reality of what God is doing in your life encourage you—because it is not about you or how great you are; it's all about Him and how great HE is. And He is not finished with His work through you!

Be observant of the kids you teach this week. As you talk about the gifts God has given each of them, invite His Spirit to help you discern their gifts and talents so that you can encourage each one to fulfill the words of today's command to use whatever gifts they have received to serve others. It may not make them rich, famous or beautiful—but it will fulfill God's purpose in their lives and give them joy beyond anything they can anticipate!

GOD'S WORD

"Each one should use whatever gift he has received to serve others."

1 Peter 4:10

FOR YOUNGER CHILDREN:

"God made you and wants you to serve others."

GOD'S WORD & ME

God created us as unique people who can use His gifts to serve others.



PLANNING PAGE

Choose which centers you will provide and the order in which children will participate in them (see pp. 14-18 for schedule tips and pp. 24-25 for guidelines in combining older and younger children). Also plan who will lead each center (for staffing tips see pp. 19-21). Use the reproducible planning sheet (p. 238) to record your plans.

BIBLE STORY CENTER

BIBLE STORY

Talents • Matthew 25:14-30

ADVENTURE BOX (YOUNGER CHILD)

Use props (large grocery bag, a medium-sized grocery bag and a small grocery bag, each stuffed nearly full with newspaper) to demonstrate story action

ADVENTURE BOX (OLDER CHILD)

Use props (five grocery bags and real or plastic coins) to demonstrate story action

ART CENTER

YOUNGER CHILD OPTION

Make unique constructions and talk about the unique ways God has made us to help others

MATERIALS

Bible, a variety of craft construction materials (cardboard tubes; craft sticks; various lengths of straws, yarn and/or chenille wire; buttons; yarn lengths; etc.), construction paper scraps, glue, tape, scissors

OLDER CHILD OPTION

Make name silhouettes, illustrating and discussing ways situations in which kids can use their abilities to serve others

MATERIALS

Bible, construction paper, several rulers, scissors, pencils, markers

GAME CENTER

YOUNGER CHILD OPTION

Collect hidden coins and talk about ways to use abilities to help others

MATERIALS

Bible, coins, lunch-size bag

OLDER CHILD OPTION

Play catch with grocery bags, repeating 1 Peter 4:10, and then talk about ways of using abilities to serve others

MATERIALS

Bible, masking tape, plastic grocery bags (one for each pair of children), small ball

COLORING/PUZZLE CENTER

YOUNGER CHILD OPTION

Review the Bible story while completing coloring page

MATERIALS

Lesson 13 Coloring Page (p. 225) for each child, crayons

OLDER CHILD OPTION

Review 1 Peter 4:10 while completing puzzle page

MATERIALS

Lesson 13 Puzzle Page (p. 226) for each child, pencils

WORSHIP CENTER

FOR THE YOUNGER AND OLDER CHILD

Participate in large-group activities to review Bible verse and to worship God together

MATERIALS

Bibles, Lesson 13 Pattern Page (p. 224), *Parable Quest* CD-ROM and CD player, song charts (pp. 246, 248), two to four objects that children can use to serve others (plastic cup, individually wrapped snack, marker, baseball, etc.), wrapping paper, tape

BONUS THEME IDEAS

Bonus Theme Ideas can be used at any time during this session: as an additional activity center, to extend the session for a longer time, or for added theme excitement.

TRAIL MIX CONES

Give each child an empty ice-cream cone. Provide a variety of trail mix items (pretzel sticks, small candies, sunflower seeds, raisins, mini-marshmallows, etc.) in separate bowls. Place several small plastic spoons in each bowl. Each child scoops a spoonful or two of each item into cone as desired.

Post a note alerting parents to the use of food. Also, check registration forms for possible food allergies.



PARABLE QUEST AWARDS

Use a certificate (see p. 229) to create a Parable Quest Award for each child who attended Parable Quest. (Optional: To each award, attach a balloon in which you have inserted a slip of paper on which is printed one of the lesson shout-outs [see p. 1 of each lesson]. Also create thank-you awards for leaders and helpers.) Present the awards to children as part of a large-group gathering, or as children are dismissed. Show video or display pictures of children participating in the activities of Parable Quest.

RAINFOREST EXPERIMENT

Ahead of time, place a small amount of each of the following spices in a small closed container (bowl with lid, film canister, etc.): ginger, vanilla, pepper, cinnamon, allspice, paprika. Invite children to smell each of these spices that come from plants grown in the rainforest. Then, demonstrate this experiment with pepper and salt. Place some salt and ground pepper on a plate. Rub an inflated balloon against your hair. Moving slowly, hold the balloon over the salt and pepper to see the pepper jump up and attach to the balloon. Add more pepper to the plate and repeat. (Optional: Provide enough supplies for groups of four children to complete the experiment.)

BIBLE STORY CENTER

FOR YOUNGER CHILDREN • MATTHEW 25:14-30

INTRODUCTION

Welcome your rainforest explorers by saying **I'm going to name something that lives in the rainforest. If it is something small, squat and make yourself small. If I name something that is middle-sized, stand up and put your hands on your hips. If I name something that is VERY big, stand on your tiptoes and put your hands in the air as high as you can!** In random order, name small things like tree frogs, ants and baby fish; name larger things like monkeys or jaguars; name very large things like tall trees, the Amazon River and rainclouds. Then show Adventure Box. **What do you think is in our Adventure Box today? Let's find out!** Untie box. Remove items from box and use them to demonstrate story action as you tell the story.



ADVENTURE BOX

In a cardboard or wooden box labeled "Adventure," place a Bible, a large grocery bag, a medium-sized grocery bag and a small grocery bag, each stuffed nearly full with newspaper. Tie rope or brown yarn around the box or crate.

TELL THE STORY

Jesus had told His friends that He was going away someday. He wanted them to know what to do while He was gone. This is a story Jesus told to help His friends know what He wanted them to do.

A very rich man was getting ready to go on a trip. Before he left, he called three of his workers. *(Beckon.)*

The rich man gave the first worker a BIG bag of money. *(Set out largest grocery bag.)* The next worker got less money, but it was still a LOT. *(Set out medium grocery bag.)* Then, the man gave another worker a smaller bag of money—but it was still a lot of money, too! *(Set out smallest bag.)* Then the rich man left on his trip.

The first worker went right to work! He said, "I'll use this BIG bag of money to make MORE money for my master!" And that's what he did! He did such a good job that he made another BIG bag of money. *(Hold up largest grocery bag.)* Now he had twice as much!

The second worker went right to work, too! He used every bit of the money and worked and worked. Soon, he had TWO middle-sized bags of money. *(Hold up medium grocery bag.)* He had made twice as much as he started with!

The third worker didn't want to DO anything with the money. He was afraid it would get lost or stolen. So the worker dug a deep hole and BURIED the bag of money. *(Place small bag behind your back.)*

After a very long time, the rich man returned. He sent for his workers. The worker who had the biggest bag of money came first. He was EXCITED to give the rich man the TWO big bags of money! "Great job! You worked hard!" the man said. *(Clap hands.)*

Then the second worker came. He was glad to give the rich man TWO middle-sized bags of money! The man was very happy. "Great job! You worked hard, too!" he said. *(Clap hands.)*

Then the last worker came. He told the rich man, "Here it is—the very same bag of money you gave me. I took care of it!"

The rich man was angry! He said he wanted his money to be used, not hidden away. The man sent the worker away.

GOD'S WORD & ME

Jesus told this story to show us that God wants us to use the special way He made us to help other people. The Bible says, "God made you and wants you to serve others." You don't have to wait to be a grown-up to do good things. God made you able to do good things and to help others right now! When we help others, we show that we love Him. Pray, Dear God, thank You for the gifts You give us. We want to help others and show we love You. In Jesus' name, amen.



BIBLE STORY CENTER

FOR OLDER CHILDREN • MATTHEW 25:14-30

INTRODUCTION

Let's have a quick quiz. If your answer is "yes," stand and pat your head. If your answer is "no," sit and wiggle your fingers in front of you. Say, **I have some money with me right now.** Children respond as instructed. Repeat with other sentences: **I have a savings account at a bank. I spend money as soon as I get it. My parents have invested money for me. I have a college fund. I have a piggy bank. I hide my money to keep it safe. I know what the word "interest" means.** (Explain terms as needed.) **Today we're going to hear about some people who did different things with a LARGE amount of money they were given.**

What do you think is in our Adventure Box today? Let's find out! Untie box. Remove items from box and use them to demonstrate story action as you tell the story.



ADVENTURE BOX

In a cardboard or wooden box labeled "Adventure," place a Bible and five grocery bags prepared in the following way: Place a good number of coins into two large grocery bags and place one bag inside the other; place additional coins into two medium-sized grocery bags and place one bag inside the other; in one small grocery bag, place one coin. Tie rope or brown yarn around the box or crate.

TELL THE STORY

Today, the word "talent" means an ability or skill a person has. But in Bible times, the word "talent" meant a large amount of money in the form of gold or silver coins. But the meaning of the word changed because of a story Jesus told called the parable of the talents. Here is Jesus' story.

A wealthy man was about to go on a journey. The man told three of his servants to take care of his money. *(Show and shake each of the grocery bags so that coins can be heard bouncing inside bags.)*

To one servant, the man gave five talents. Wow! That was a LOT of money—depending on the kind of metal, it might have been MILLIONS of dollars. *(Give largest bag to a volunteer to hold.)*

To another servant, the man gave two talents—maybe HUNDREDS OF THOUSANDS of dollars! *(Give medium-sized bag to a volunteer to hold.)*

The man gave one talent to a third servant—which was still a LOT of money, maybe TENS OF THOUSANDS of dollars! *(Give smallest bag to a volunteer to hold.)*

Once the rich man left, the first two servants put their money to work! Perhaps one of them bought a good field and grew grain, and then sold the grain at the marketplace. Maybe one of the servants bought spices from a traveling caravan and then packaged and sold the spices in the marketplace. Or maybe they bought sheep and sheared the wool and made clothes and blankets. Whatever they did with the money, they used what they had been given and made the most of it for the rich man! *(Two volunteers with biggest bags shake the bags.)*

Both of these servants were working really hard, investing what they'd been given to make more. But wasn't there another servant? Oh yes. There was the servant who'd been given one talent. What was HE up to?

This servant was a fearful man. No investing for HIM! Instead, he went out, dug a hole and buried his talent! But he wasn't doing anything to make more money for his master! *(Invite volunteer holding smallest bag to sit on it!)*

On the day when the rich man returned, he called those three servants into the house. The first one came in eagerly. *(Invite volunteer holding largest bag to pull out folded bag so that there are two large bags.)* "Look," he said. I have DOUBLED the money you entrusted to me!"

The rich man was DELIGHTED! He said, "Well done! You're a good servant, faithful to keep on working when I was gone. I'll give you even more important work to do!"

Then the second servant came in, eager to show what he'd done. *(Invite volunteer holding medium-sized bag to pull out folded bag so that there are two medium-sized bags.)* "I have good news!" he said. "I have also DOUBLED my investment." Once again, the rich man was DELIGHTED! He said, "Well done! You're a good servant, faithful to keep on working when I was gone. I am so pleased! I'll give you even more important work to do!"

Now there was one servant left. When he came in to see the rich man, he started with a little speech of excuses. He said, "I was afraid to LOSE your money. So instead, I carefully hid it in the ground. But now, here it is." *(Invite volunteer sitting on smallest bag to bring it out and dump out coin.)*

The rich man was NOT pleased! In fact, he said, "You should at LEAST have put this money into the bank and gotten some interest on it! You did NOTHING with what I gave you!" The master gave orders to have this servant thrown out—and he gave that one dusty talent to the hard-working first servant!

GOD'S WORD & ME

Jesus was telling us to use every gift God has given us to serve others, no matter how great or how small we think those gifts are. Every day, we can be on the lookout for opportunities to use the unique way God has made us to help others.

- **What are the two meanings of the word "talent"?** (A unit of money. A gift, skill or ability.)
- Invite a child to read aloud 1 Peter 4:10. **What is a gift, talent or ability God has given you? God has made each of us in a unique way with a combination of likes and dislikes and abilities that no one else has.**
- **What is a way you could use an ability given to you by God to serve others?** After children respond, pray with them, thanking God for their abilities and asking for His help to use those abilities to serve others and please Him.



GAME CENTER

FOR YOUNGER CHILDREN • MATTHEW 25:14-30

COLLECT

Bible, coins, lunch-size bag.

PREPARE

Hide coins around room or outdoor playground.

DO

1. At your signal, children collect the hidden coins and place them in bag. (If needed, limit the number of coins each child may collect.)
2. Repeat game, allowing several children to hide the coins for each round.
3. For an additional challenge, hide the bag of coins. One child searches for the bag as you lead group in calling out "Hot" when child is moving close to the bag and "Cold" when child is moving far away from the bag.

TALK ABOUT

- It's fun to look for the hidden money. Jesus told a story about a man who gave his workers money called "talents." The workers were supposed to use the money in good ways. Jesus told this story so we would know that each of us can do good things to help others.
- The Bible says, "God made you and wants you to serve others." When we serve others, it means we help them have the things they need. Who is in your family? What is something they need? (Something to eat or drink. Help to carry something.) How can you help them?
- God has made each of us in special ways so that we can serve others. Being friendly is a good way to help others. Who are your friends? What can you do to be a good friend? (Help a friend with a chore. Let a friend choose what game to play.)
- Pray briefly, Dear God, thank You for making us in special ways. Please show us how we can help and serve others. In Jesus' name, amen.

FOR OLDER CHILDREN

Children collect coins, but do not place them into the bag until all have been found. Then, as each child places a coin into the bag, he or she tells a way to use an ability to serve someone, or says a word of the verse in order.

GOD'S WORD

"Each one should use whatever gift he has received to serve others."
1 Peter 4:10

FOR YOUNGER CHILDREN:

"God made you and wants you to serve others."

GOD'S WORD & ME

God created us as unique people who can use His gifts to serve others.



GAME CENTER

FOR OLDER CHILDREN • MATTHEW 25:14-30

COLLECT

Bible, masking tape, plastic grocery bags (one for each pair of children), small ball.

PREPARE

Use masking tape to make a line dividing an open area in your room.

DO

1. Divide the group into two teams. Teams stand on either side of the masking-tape line and form pairs within their teams.
2. Give each pair a grocery bag. Pairs take turns tossing small ball across the line to each other, attempting to catch the ball inside their grocery bags.
3. Once a ball has been tossed and caught three times in a row, members of team who last caught the ball tell a way to use an ability to serve others or says the words of 1 Peter 4:10. Repeat game as time permits, occasionally asking children to form new pairs.

TALK ABOUT

- Read 1 Peter 4:10 aloud with children. **What does this verse tell us to do? When do you think this would be easy to do?** (When your best friend needs help.) **When might it be hard?** (When your little brother asks you for help over and over again.) **Why?**
- **In what ways have you seen kids your age use their abilities to serve others?** (Help a younger child read a book. Practice a sports skill with a friend.) **How did their actions make a difference?** (Helped others learn to do something.)
- **Who are some groups of people in your school or our city who might need to be served? What can you, your family or the people in our church do to serve them? What is something you think your family could do that is different from what others can do? What abilities has God given the people in your family?**
- Lead children in prayer, asking God to show them the abilities God has given them and ways to use the abilities to serve others.

FOR YOUNGER CHILDREN

Children sit in a circle on the floor. As each child takes a turn to roll the ball to someone else in the circle, he or she tells the name of someone to help and/or a way to help the person.

GOD'S WORD

"Each one should use whatever gift he has received to serve others."
1 Peter 4:10

FOR YOUNGER CHILDREN:

"God made you and wants you to serve others."

GOD'S WORD & ME

God created us as unique people who can use His gifts to serve others.



ART CENTER

FOR YOUNGER CHILDREN • MATTHEW 25:14-30

COLLECT

Bible, a variety of craft construction materials (cardboard tubes; craft sticks; various lengths of straws, yarn and/or chenille wire; buttons; yarn lengths; etc.), construction paper scraps, glue, tape, scissors.

DO

1. Children create constructions using the materials you have provided.
2. As children glue and tape their constructions together, encourage each child in creating a unique construction.

TALK ABOUT

- I like to see all the things you are building. Each person is constructing something different. God made us so that we can do different things.
- The Bible says, “God made you and wants you to serve others.” When we serve others, it means we can do good things to help them. Some of you have brothers or sisters at home. What is something good you can do to help your (brother)?
- What do you like to do to help in our classroom? At home? God made each of us in special ways so that we can serve and help others. Pray briefly, thanking God for each child and asking His help in showing children ways to help and serve others.

FOR OLDER CHILDREN

Provide additional materials such as rubber bands, toothpicks, buttons, string and paper clips. Encourage children to work in pairs to build constructions.

GOD'S WORD

“Each one should use whatever gift he has received to serve others.”
1 Peter 4:10

FOR YOUNGER CHILDREN:

“God made you and wants you to serve others.”

GOD'S WORD & ME

God created us as unique people who can use His gifts to serve others.



ART CENTER

FOR OLDER CHILDREN • MATTHEW 25:14-30

COLLECT

Bible, construction paper, several rulers, scissors, pencils, markers.

PREPARE

Make a sample name silhouette and drawing by following the directions below.

DO

1. Show the name silhouette and drawing you prepared and describe the way in which it shows you can serve someone using an ability. Ask children to suggest situations and abilities appropriate to themselves.
2. Give each child a sheet of construction paper. Child folds paper in half lengthwise and draws a light pencil line about 1 inch (2.5 cm) above the fold (see sketch a). Then child uses marker to write his or her first name on the line, writing the letters as large as possible to fill up the paper. Children cut around the top of name without cutting through the fold (see sketch b).
3. Once their names are cut out, children unfold papers. Inside the name silhouettes, children draw a picture of a situation in which they can use an ability to serve someone (see sketch c).

TALK ABOUT

- Read 1 Peter 4:10 aloud with children. **How does someone act who is obeying this verse? When have you seen examples of someone serving others?** (A friend who helped me practice baseball. My big sister who helped me with my homework.)
- **How many ways can you think of to serve someone in your home? In our class at church? In our city?** Invite children to tell their ideas. **What is a special interest or ability you'd like to learn about? As you grow, you can ask God to help you discover the unique abilities He's given you.**
- **What can you do when you don't feel like serving and helping someone?** (Ask parent to serve with me. Pray to God for help to obey. Remember the good things God has given me that He wants me to share with others.) Pray, thanking God for the unique way in which He has created each person and asking His help in serving others, even when it's difficult.

FOR YOUNGER CHILDREN

Instead of making name silhouettes and drawing situations, children draw themselves and friends who they can serve by helping.

GOD'S WORD

"Each one should use whatever gift he has received to serve others."
1 Peter 4:10

FOR YOUNGER CHILDREN:

"God made you and wants you to serve others."

GOD'S WORD & ME

God created us as unique people who can use His gifts to serve others.

a.

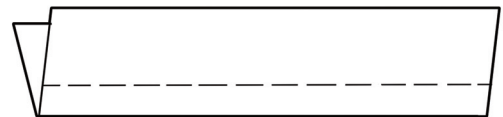

b.

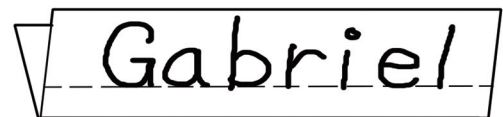

c.

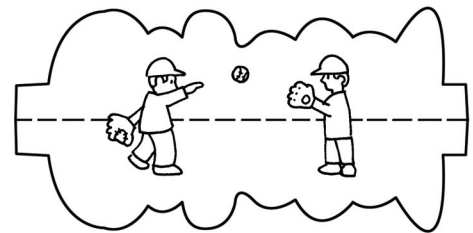

WORSHIP CENTER

MATTHEW 25:14-30

COLLECT

Bibles, Lesson 13 Pattern Page (p. 224), *Parable Quest* CD-ROM and CD player, song charts (pp. 246-248), two to four objects that children can use to serve others (plastic cup, individually wrapped snack, marker, baseball, etc.), wrapping paper, tape.

PREPARATION

Photocopy Lesson 13 Pattern page and cut apart. Make enough copies so that each child will have a verse card. Wrap two to four objects with many layers of wrapping paper.

TEAM GAME

Divide group into two to four teams. Ask for a volunteer from each team. At your signal, each volunteer begins unwrapping a gift. Teams cheer for their volunteer. Volunteer who unwraps gift first wins for his or her team. When each gift is unwrapped, have teams tell how the object can be used to serve someone.

BIBLE VERSE GAME

Repeat 1 Peter 4:10 aloud with children. In random order, give each child a verse card you prepared. At your signal, children stand and begin moving around the room, trying to find others who are holding the same verse card. When all children are grouped, they call out the words of the verse in order. Repeat as time permits, redistributing verse cards for each round.

SONG

You, or another leader, lead children in singing "All of the Time," adding motions and/or clapping if desired.

PRAYER

Ask volunteers to tell how they would complete the following sentence: "One way a kid can serve someone is by . . ." Repeat with two other sentences: "God wants me to serve others because . . ." and "The best way someone served me was . . ." Then lead children in prayer, thanking God for creating us as unique people and asking Him to show us opportunities to serve others.

SONG

You, or another leader, lead children in singing "Following Jesus," adding motions and/or clapping if desired.

GOD'S WORD

"Each one should use whatever gift he has received to serve others."
1 Peter 4:10

FOR YOUNGER CHILDREN:

"God made you and wants you to serve others."

GOD'S WORD & ME

God created us as unique people who can use His gifts to serve others.



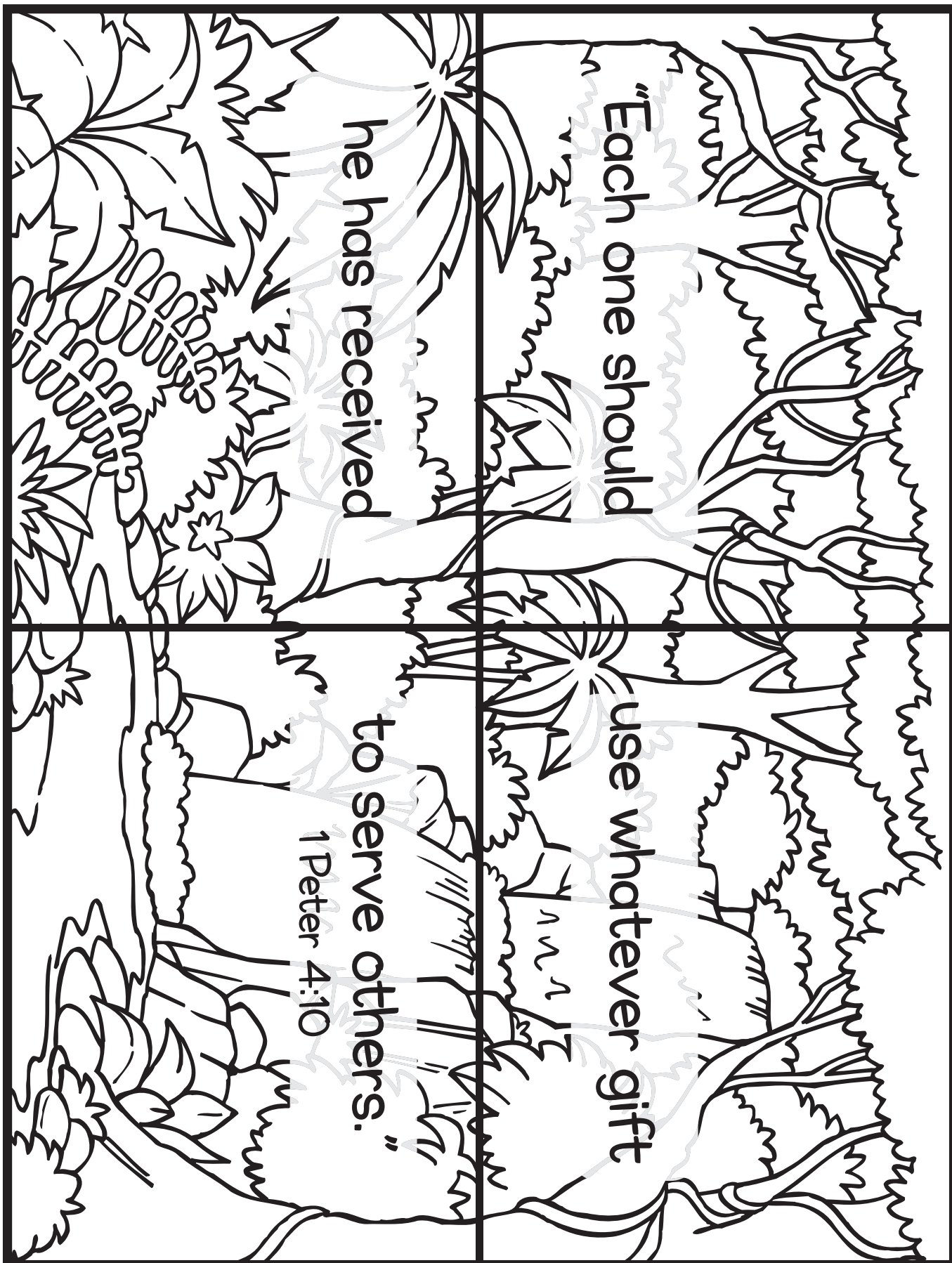

Each one should

use whatever gift

he has received

to serve others.

1 Peter 4:10

Jesus tells about a master and three workers.

Matthew 25:14-30

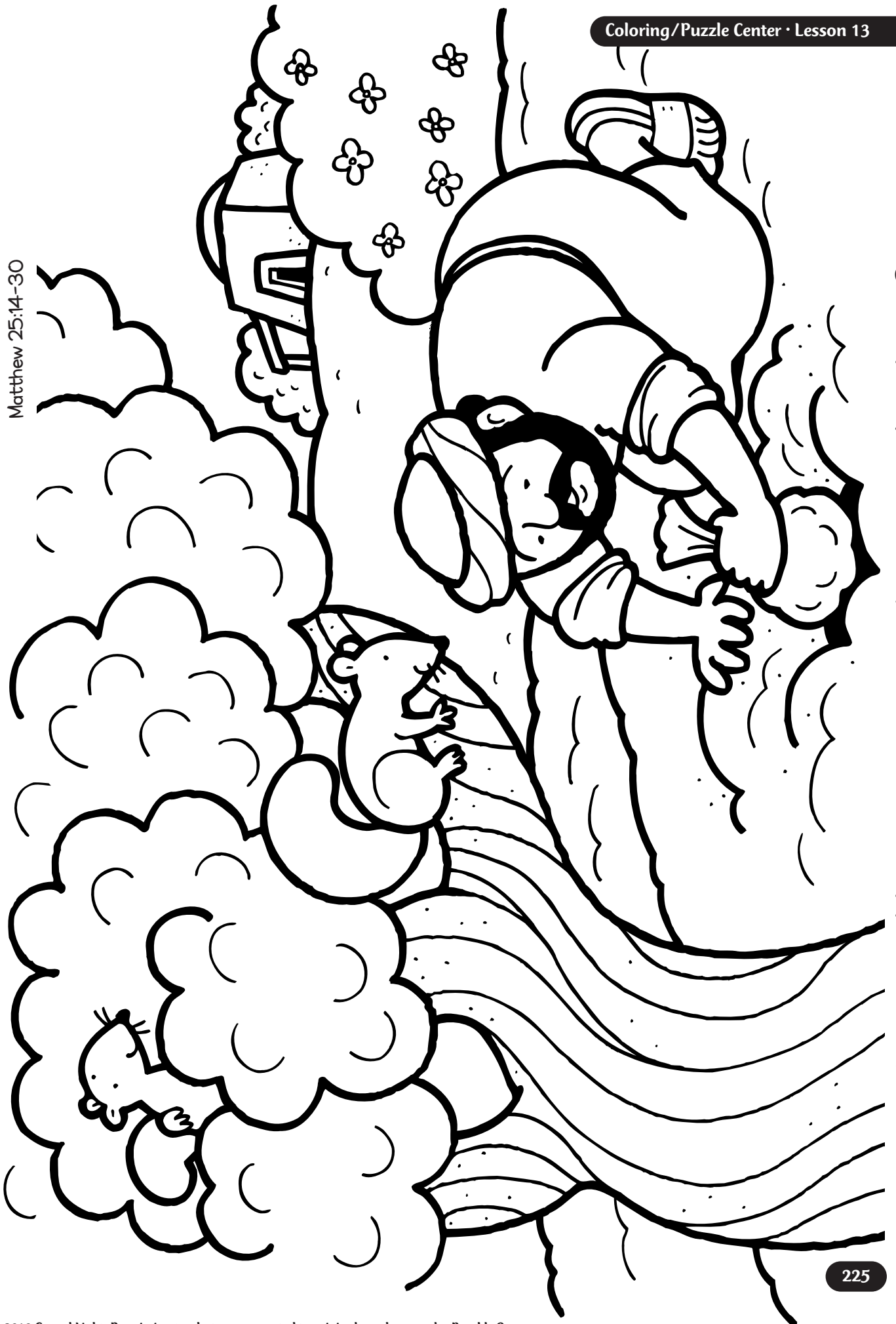

One worker did not serve his master. Who can you help and serve?

RAINFOREST ROCKS!

1. Find the hidden animal names and write them in the puzzle.
2. Then write the circled letters in order in the blanks.
3. Read down the center column AND the blanks for an important message.

boa constrictor

caiman

chameleon

pounces!

Moves slowly

Changes color!

Clings to walls!

Hides in bromeliads!

Hides frogs!

squeezes HARD!

Rainforest alligator!

Flies at night!

In your yard and in the rainforest!

Food for Caiman!

Slides on it's belly!

What's a way you can serve others this week?

bat

gecko

snake

sloth

fish

jaguar

TO _____ VE
_____ RS!

Grid letters: Row 1: J A [] A []; Row 2: [] [] O [] H; Row 3: C [] [] [] [] n; Row 4: [] [] G [] [] []; Row 5: B R O M E L I A D; Row 6: [] [] [] [] [] [] []; Row 7: [] A [] A []; Row 8: [] A [] S []; Row 9: [] A [] [] E []; Row 10: [] [] [] [] [] [] []



RESOURCES

Look in this section to find helpful resources that you can customize for use in your church. You will find theme-related art, decorating patterns, a lesson-planning page, song charts, publicity flyers and more!

CERTIFICATES

Use these certificates to recognize and honor children, teachers and helpers.

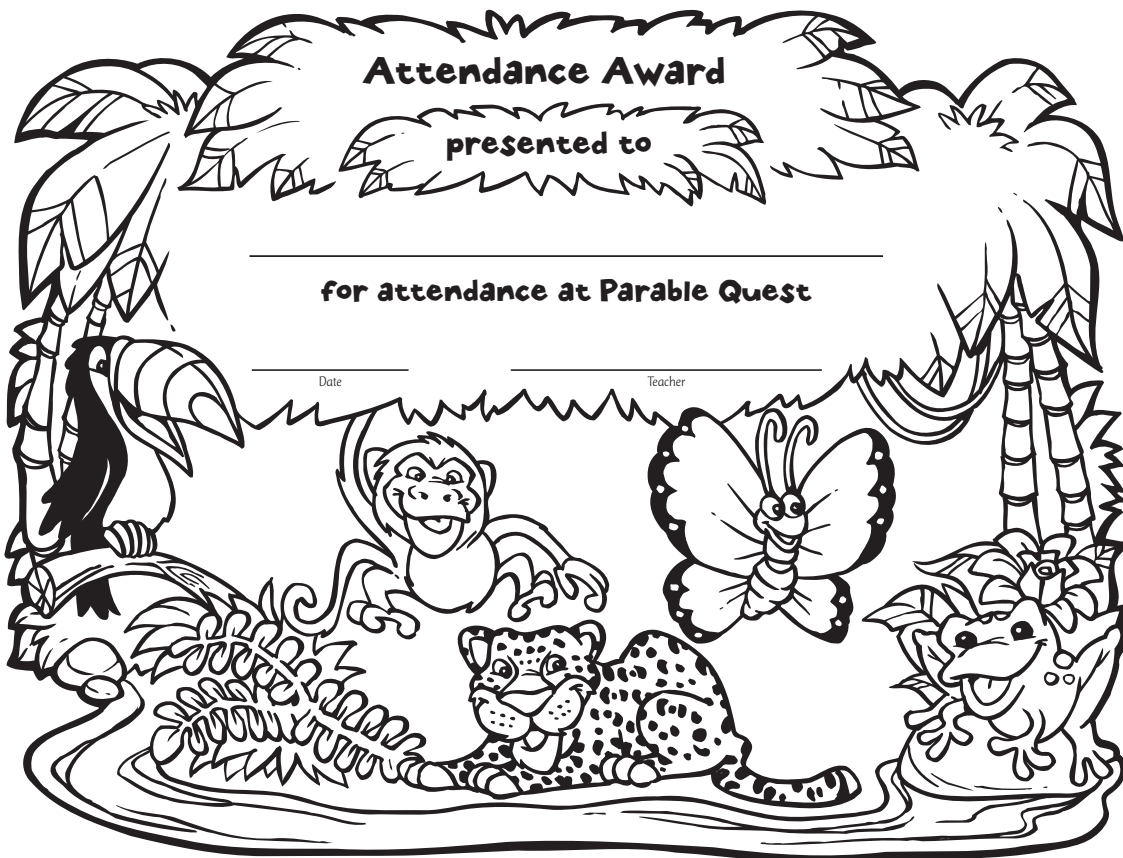
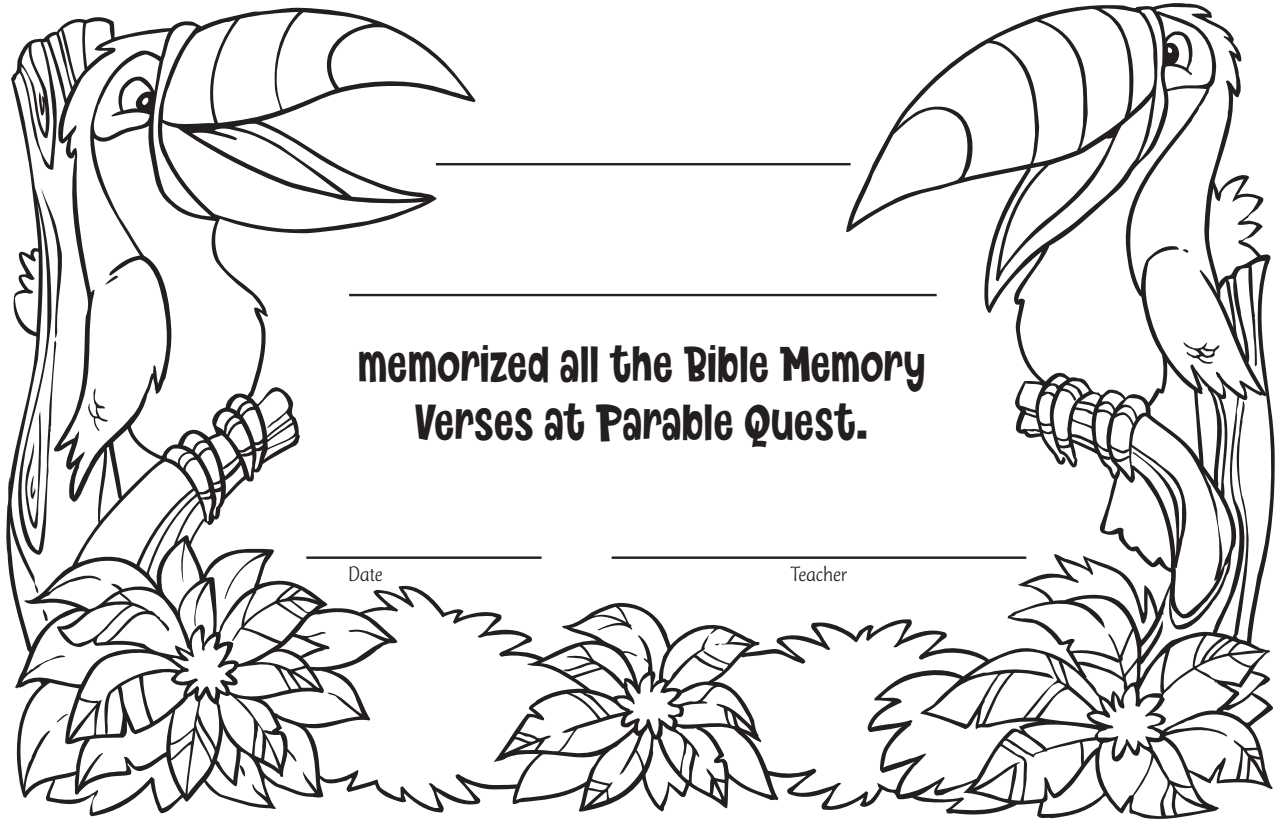

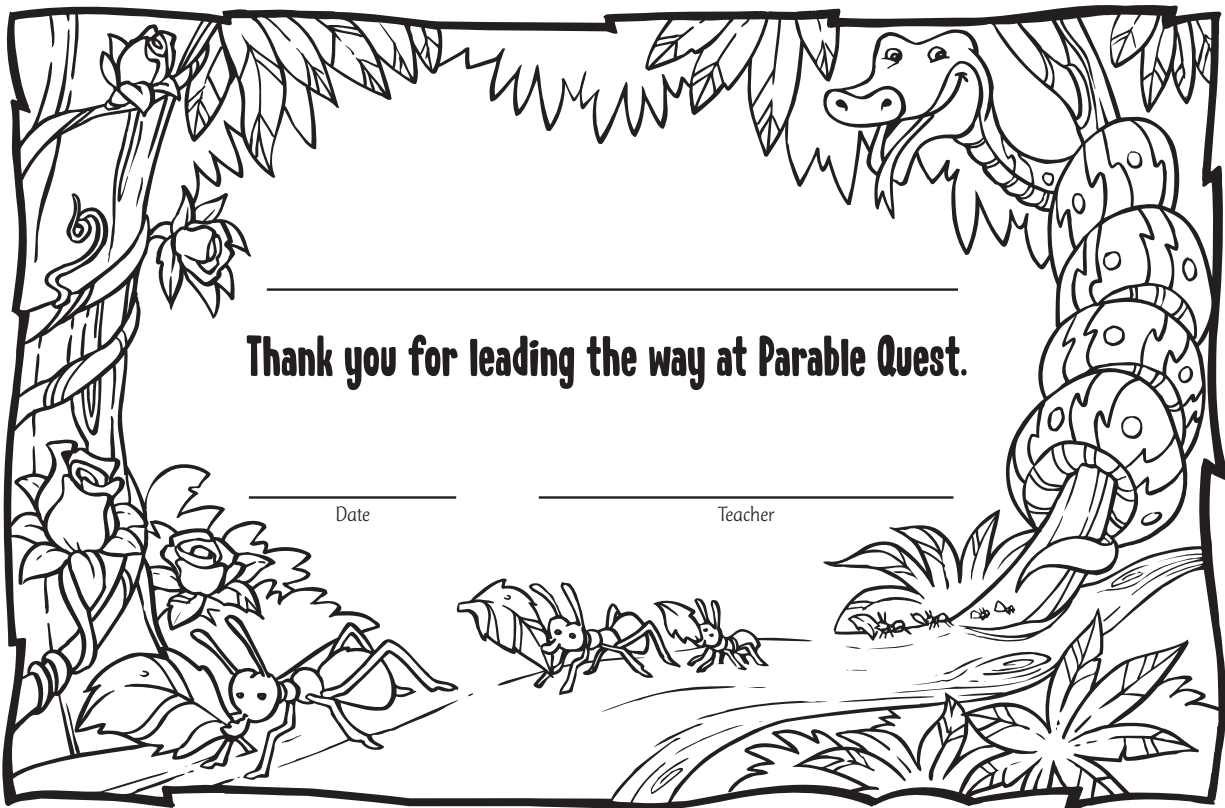

Thank you for leading the way at Parable Quest.

Date

Teacher

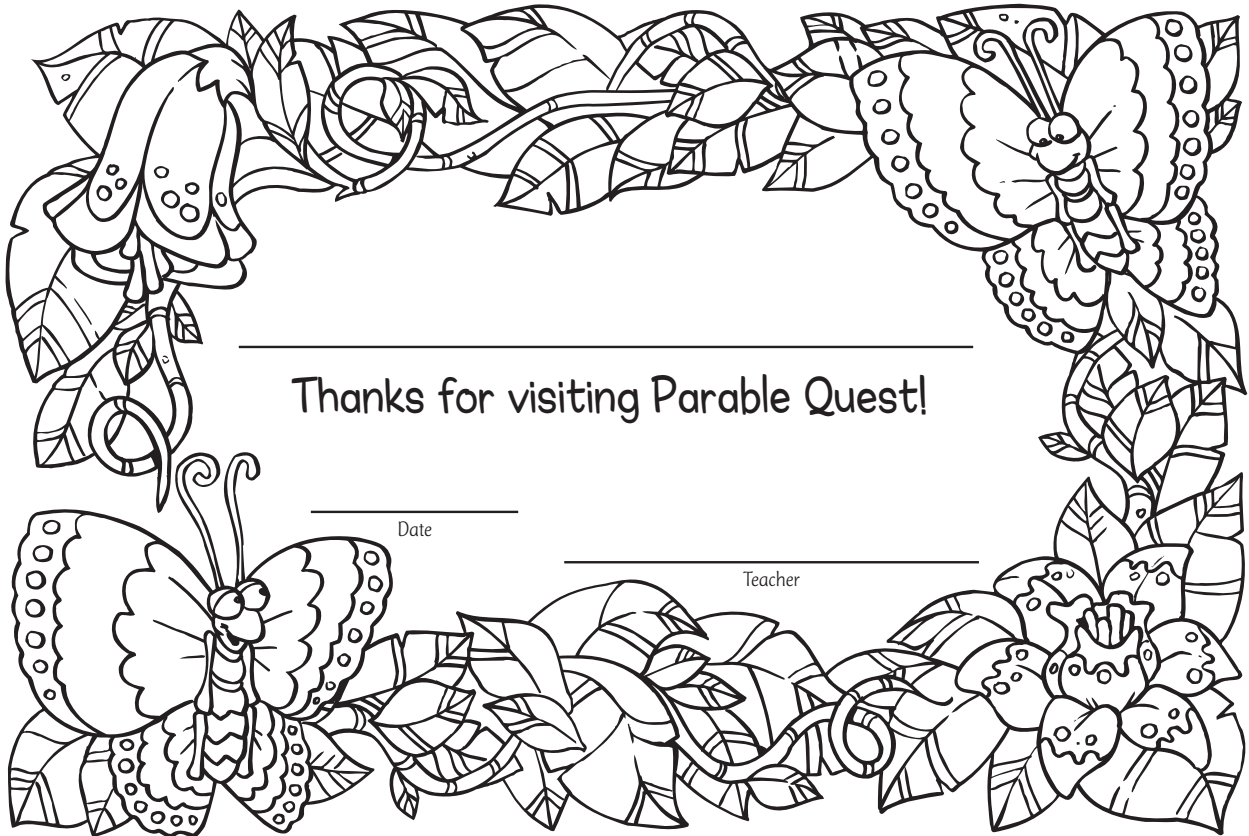

Thanks for visiting Parable Quest!

Date

Teacher

FAMILY TALK

ONE THING WE ALREADY KNEW

ONE THING WE DID NOT KNOW

Today's Date

WHAT WE READ

ONE TRUTH WE LEARNED FROM JESUS'
PARABLE

ONE WAY THE BIBLE MEMORY VERSE
HELPS US KNOW HOW TO LIVE

ONE THING TO THANK JESUS FOR

ONE THING TO ASK JESUS FOR

PARENT LETTERS

Help parents become familiar with *Parable Quest* and encourage their child's attendance by sending a letter to each family several weeks before the program begins. Use this sample letter as inspiration to create your own letter. On page 233 you'll find two invitations you can modify to invite parents to join in on the fun at *Parable Quest*. The *Parable Quest* CD-ROM contains modifiable versions of these letters.

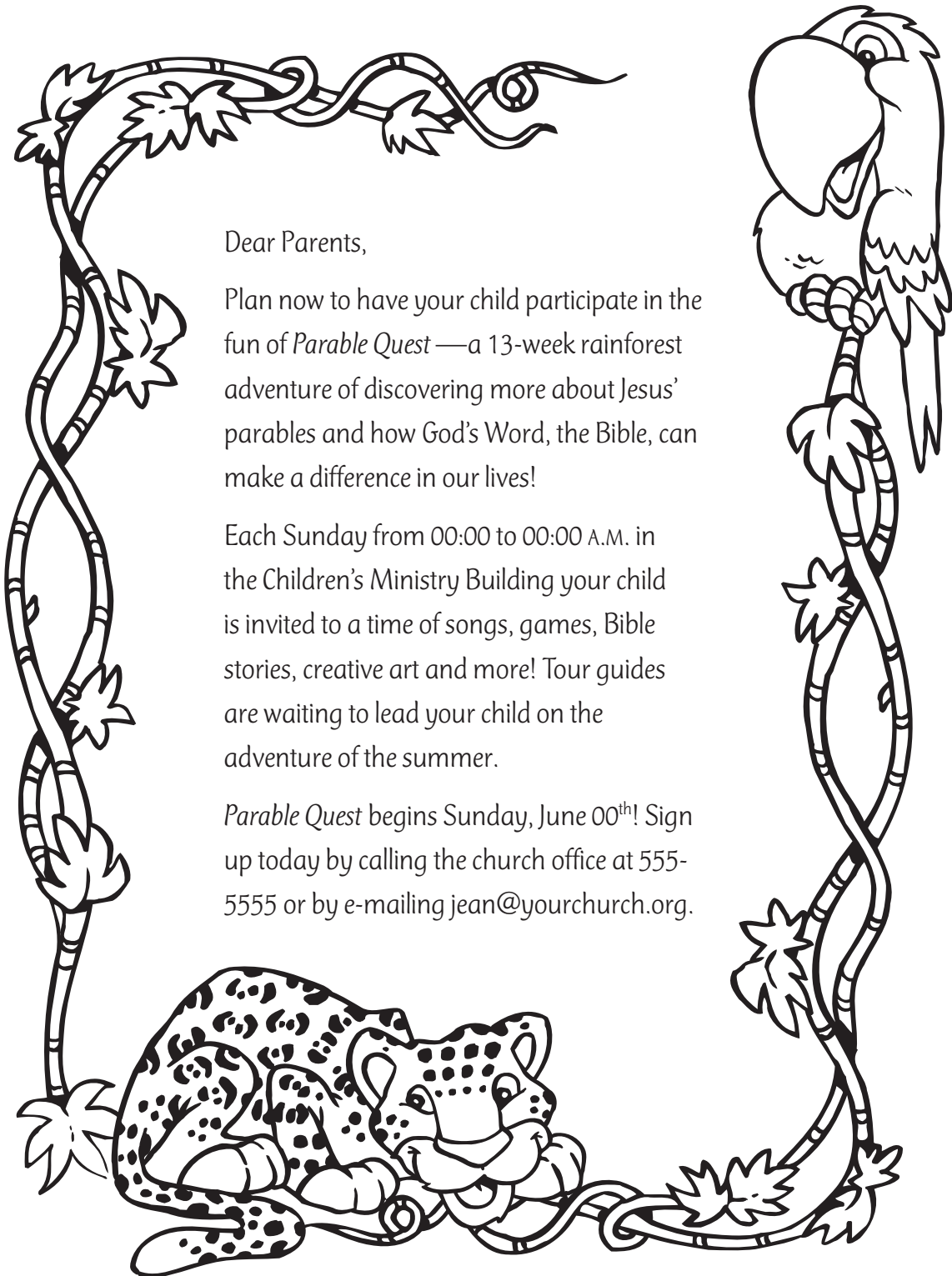

Dear Parents,

Plan now to have your child participate in the fun of *Parable Quest* — a 13-week rainforest adventure of discovering more about Jesus' parables and how God's Word, the Bible, can make a difference in our lives!

Each Sunday from 00:00 to 00:00 A.M. in the Children's Ministry Building your child is invited to a time of songs, games, Bible stories, creative art and more! Tour guides are waiting to lead your child on the adventure of the summer.

Parable Quest begins Sunday, June 00th! Sign up today by calling the church office at 555-5555 or by e-mailing jean@yourchurch.org.

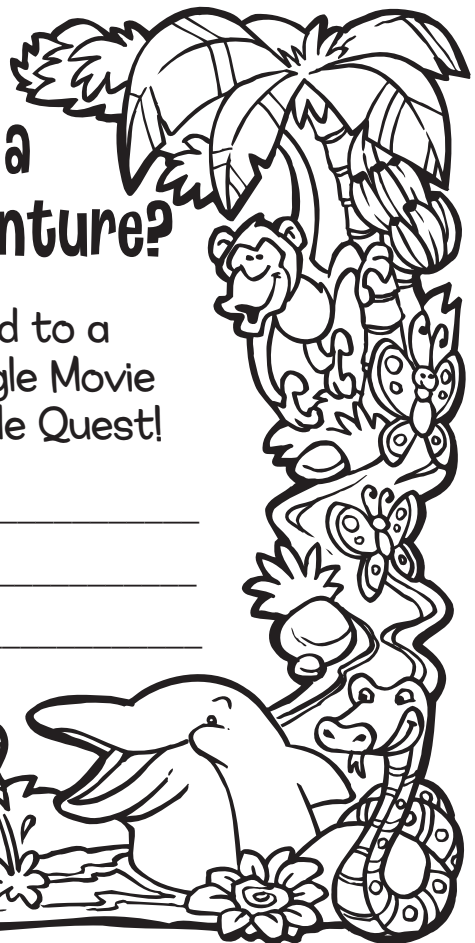

Ready for a rainforest adventure?

You're invited to a Family Fun Jungle Movie Night at Parable Quest!

Date _____

Time _____

Place _____

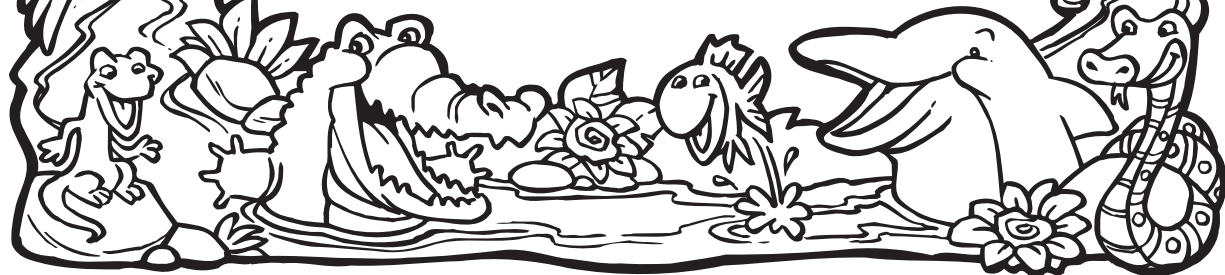

You're invited to a HILARIOUS Family Adventure Day at Parable Quest!

Date _____

Time _____

Place _____

Come join your kids on a rainforest adventure!
Please bring an outdoor game to share (soccer ball, Frisbee, etc.).
Call Jean Brown at 555-5555 for more information.



PATTERNS

Use these patterns to enhance bulletin announcements, forms and flyers. Patterns can also be used to decorate bulletin boards, classrooms, hallways and church buildings. Follow these three easy steps to enlarge patterns:

1. Make overhead transparencies of the patterns using a photocopier, and then project patterns onto butcher paper taped onto wall or onto portions of large appliance boxes.
2. Trace patterns with pencil.
3. Cut out patterns and then use markers or paint to color them. (Hint: To save time, you may also project patterns directly onto construction paper.)

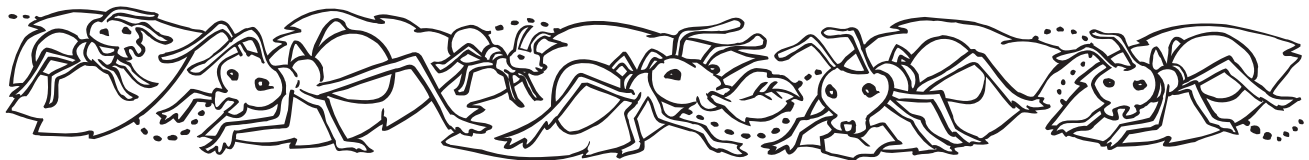
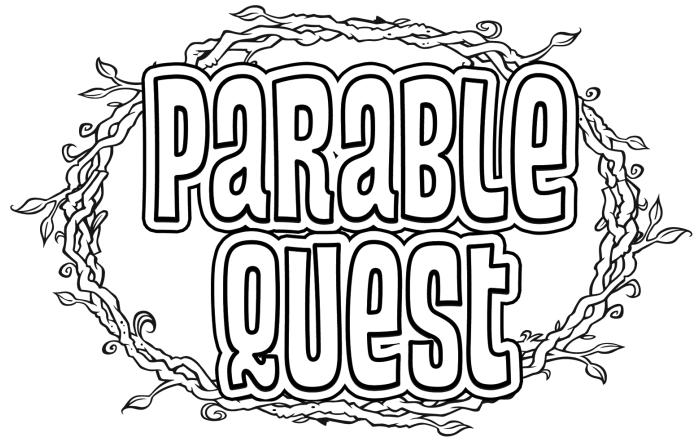
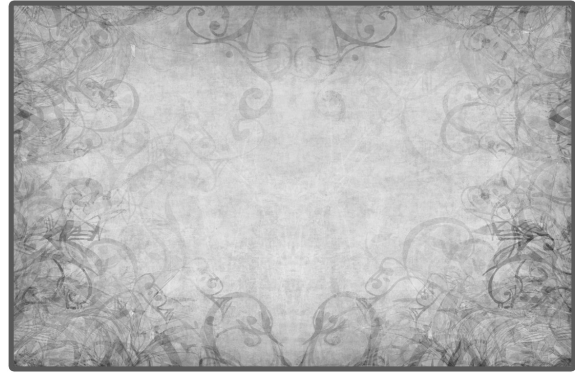
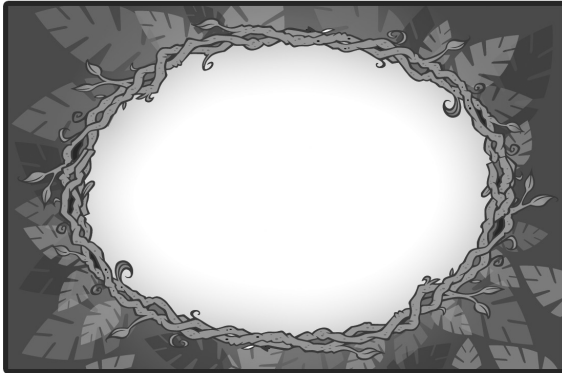





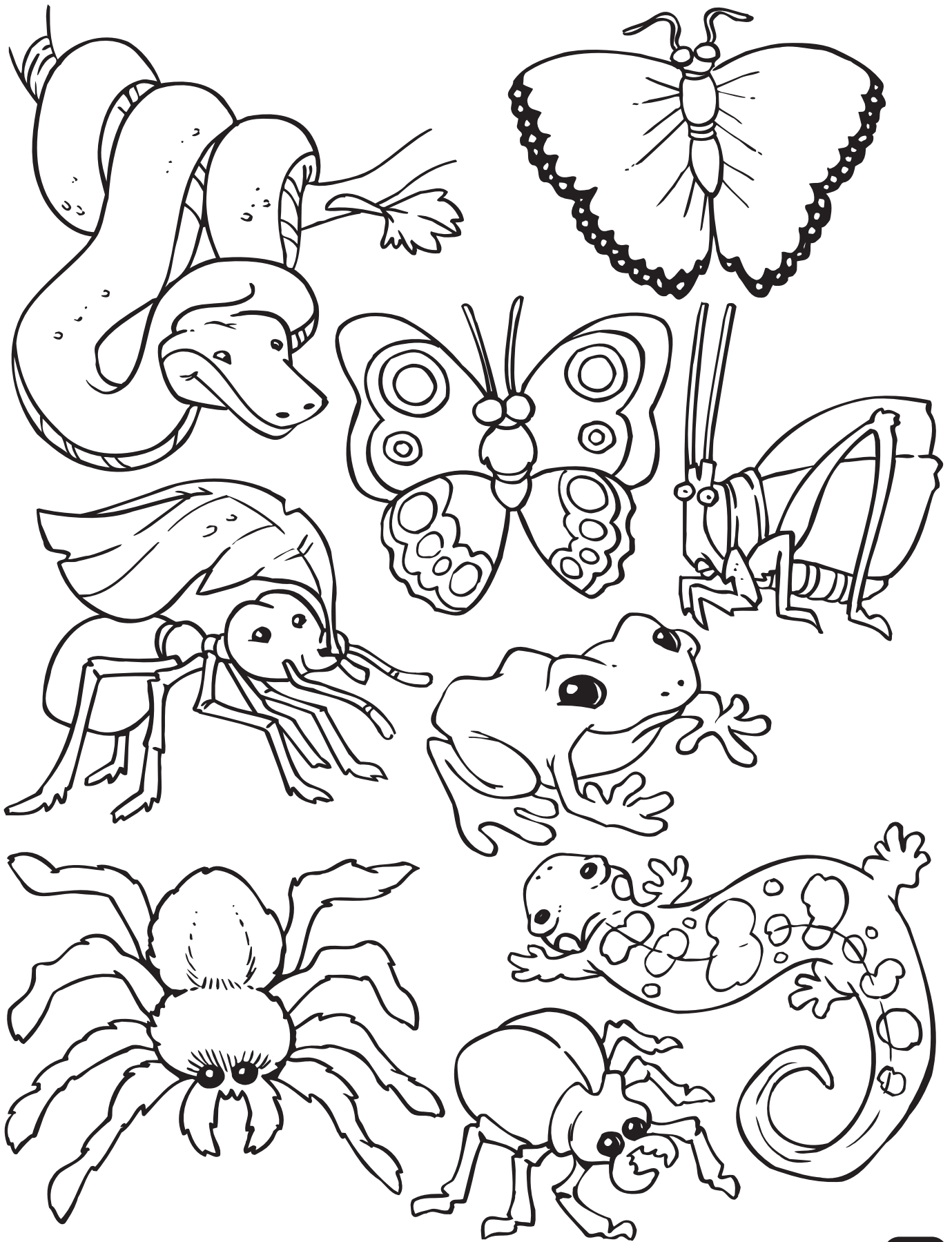

PARABLE QUEST

DATE(S)

LESSON # AND TITLE

TEACHING TEAM

TIME

CENTER

MATERIALS

TEACHERS

HELPERS

PUBLICITY FLYERS

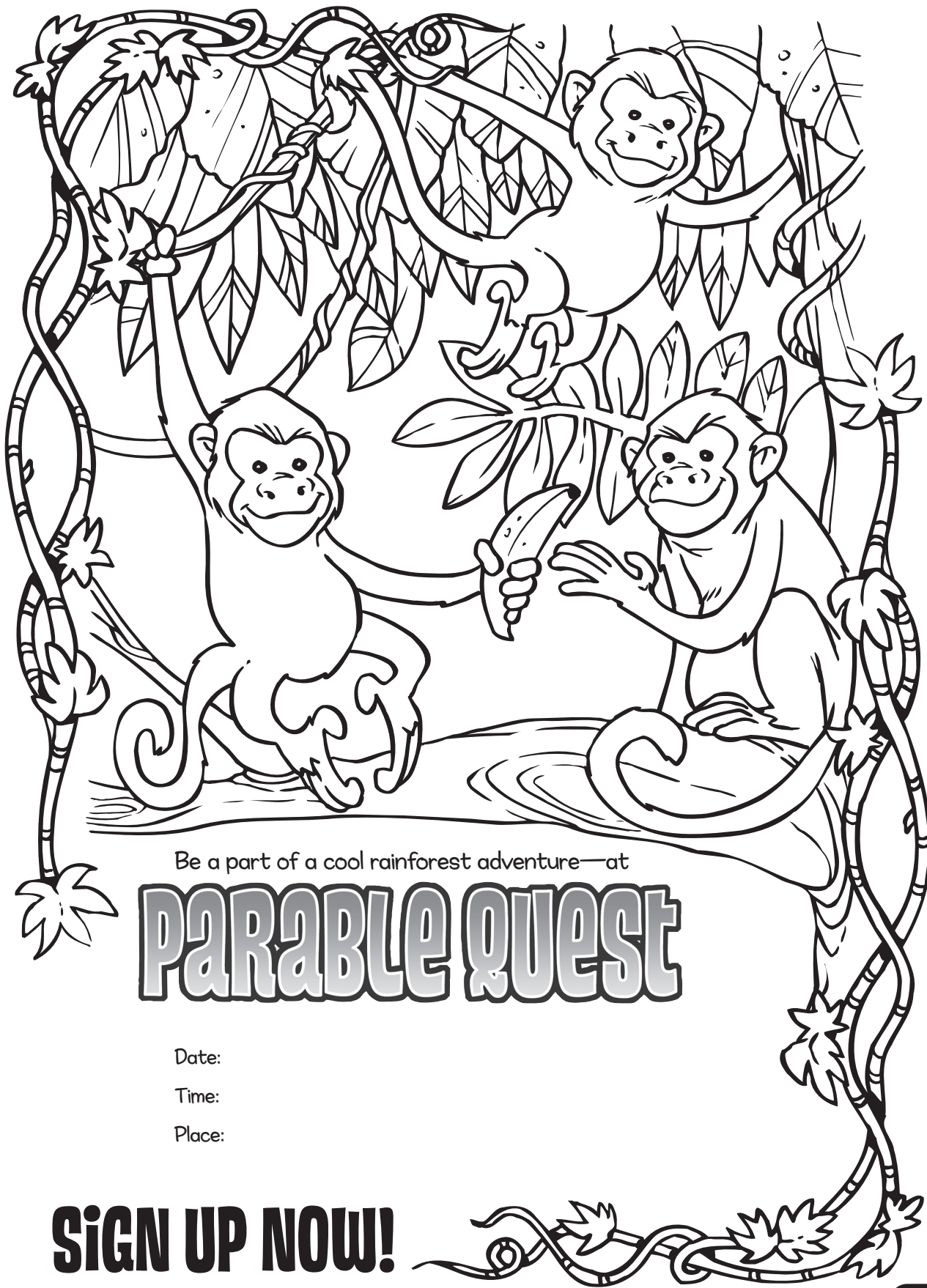

Be a part of a cool rainforest adventure—at

PARABLE QUEST

Date:

Time:

Place:

SIGN UP NOW!



**Come for fun and more at Parable Quest—
don't miss it!**

Date:

Time:

Place:

SIGN UP NOW!

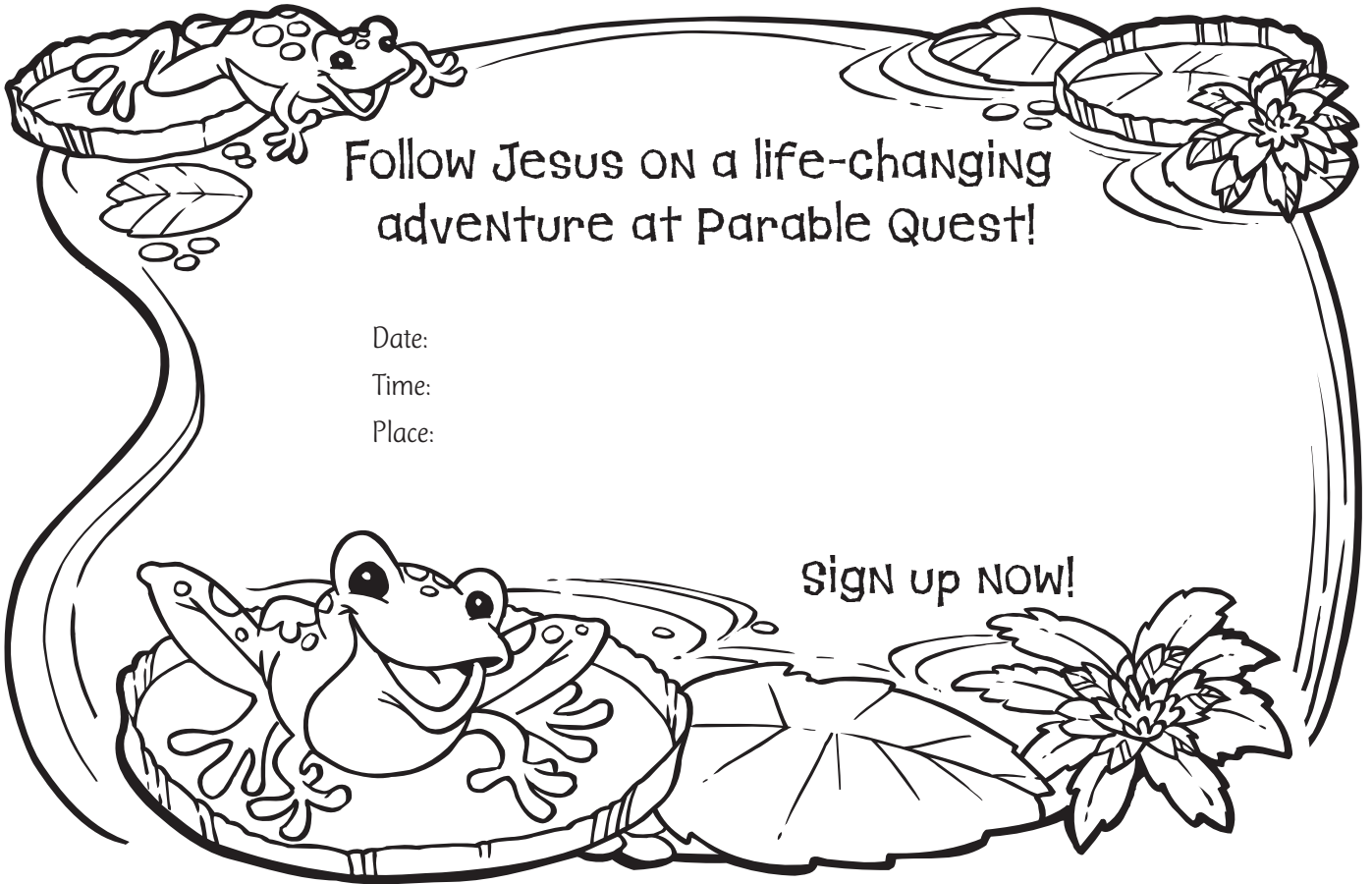

Follow Jesus on a life-changing
adventure at Parable Quest!

Date:

Time:

Place:

Sign up NOW!



At Parable Quest,
we'll keep the rainforest fun going on and on!

Date:

Time:

Place:

Sign up today!

PUZZLE ANSWERS

Lesson 1 • Coloring/Puzzle Center

PARTY BALLOONS!

It's party time! And every balloon holds letters to unscramble. Write them in order below to find out why we're partying!

What's a way to celebrate becoming part of God's family?

Draw your happy face!

John 1:12 Write it here!

To all who received him to those who believed in his name he gave the right to become children of God.

58 © 2010 Gospel Light. Permission to photocopy granted to original purchaser only. Parable Quest

Lesson 2 • Coloring/Puzzle Center

SHINE EVERY DAY!

Help Reuben and Rachel move through the maze—and through every box!

Tip #1: There may be more than one path!

Tip #2: It's OK to go "under" paths!

Which of these everyday ways to shine will you do today?

You're a shiner!

SHINE!

START

72 © 2010 Gospel Light. Permission to photocopy granted to original purchaser only. Parable Quest

Lesson 3 • Coloring/Puzzle Center

FROM FOOL TO WISE!

First, use the clues below to change "fool" to "wise." Then, start at the dot to circle every other letter. Write the circled letters below to read what James has to say about being wise! (The dots show where words start.)

Someone who doesn't listen—

What sheep wear—

What trees become—

What isn't narrow—

Someone who listens and does God's commands!

What's a command you want to obey?

J M R P O L A B B M C C N D E F G H I J K L A
O M N O O L E S . . . O M J U G A N C O W T A J A R P C

Do not merely listen to the word . . . do what it says.

86 © 2010 Gospel Light. Permission to photocopy granted to original purchaser only. Parable Quest

Lesson 4 • Coloring/Puzzle Center

FRUITFUL!

What's a way you can work on being fruitful today?

learn to love and obey God's Word to be fruitful!

100 © 2010 Gospel Light. Permission to photocopy granted to original purchaser only. Parable Quest

Big, Big Tree!

Unscramble the letters to fill in the blanks. Then read UP from the bottom for the message!

5. is t h e l o v e o f C h r i s t .

4. a n d h i g h a n d d e e p

3. h o w w i d e a n d l o n g

2. m a y h a v e p o w e r . . . t o g r a s p

1. I p r a y t h a t y o u , b e i n g r o o t e d . . . i n l o v e .

What's a way you know God loves you?

114

© 2010 Gospel Light. Permission to photocopy granted to original purchaser only. Parable Quest

START

Who is a person you need to forgive today?

G O D F O R G I V E S Y O U !

FINISH

MERCY ME!

When the first letter of each object next to the object. Then as you go through the maze, write the correct letters to fill in the blanks below.

128

© 2010 Gospel Light. Permission to photocopy granted to original purchaser only. Parable Quest

a COORDINATED MESSAGE!

Use the letters and numbers (called coordinates) to fill in the blanks below.

A	E	L	X	F	K	d	a	S	k	S
B	U	Z	D	h	e	O	T	G	j	h
C	a	n	Y	b	Y	c	Z	O	W	L
D	M	O	b	X	l	W	a	L	i	Z
E	p	e	P	C	v	R	Q	d	u	t
F	F	R	Y	O	W	X	B	C	v	B
G	G	q	J	M	P	v	g	W	A	D
H	J	q	i	l	g	i	C	q	T	S
I	R	N	n	h	K	E	F	U	K	L
	1	2	3	4	5	6	7	8	9	10

G-8, W
F-4, O
D-6, W

What's a way you can do this?

D O M O R E
B-3 F-4 C-9 D-2 I-1 E-2

T H A N
H-9 B-4 D-7 C-2

T A L K
B-7 G-9 A-2 I-5

P U T Y O U R
E-1 I-8 E-10 C-3 F-4 E-9 E-6

W O R D S I N T O
D-6 F-4 F-2 E-8 A-10 H-6 C-2 B-7 F-4

A C T I O N !
C-1 E-4 H-9 D-5 F-4 C-2

142

© 2010 Gospel Light. Permission to photocopy granted to original purchaser only. Parable Quest

MAKE A MOUNTAINOUS EFFORT!

Crack the code to discover what these mountain climbers (and you) should keep on doing! Cross out the Qs, Xs and Zs. Then read your way across the mountains. Write the letters in order below, and divide them into words.

What's something you can pray about every day this week?

156

© 2010 Gospel Light. Permission to photocopy granted to original purchaser only. Parable Quest

a HEART IN SHAPE!

Find the letter in each shape to discover how to make your heart strong!

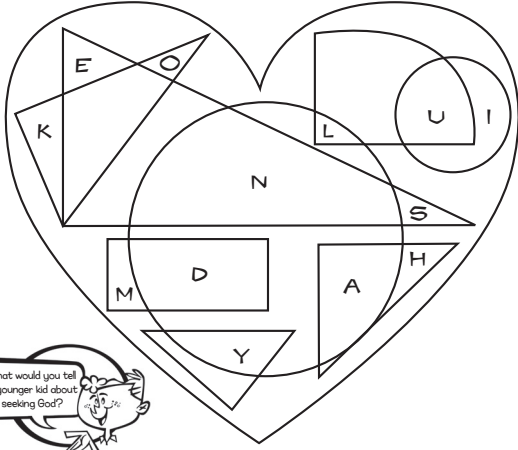

I seek you with
all my heart...

a PUZZLING INVITATION!

Some of the letters fell off this invitation! They're all vowels. Help Henry figure out what it says.



u i e e o i e
i i e a e i a i o
o o i e o u

Unscramble the words on the balloons below to help Henry answer!

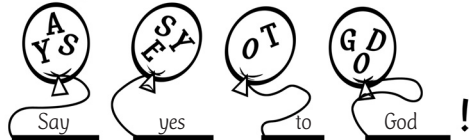

a STEP IN THE RIGHT DIRECTION!

Help the lost boy get home—and discover an important message!

Starting at "I," collect every other letter. When you get to the pippen, turn around! Start with "A" to collect every other letter. As you go, write down every letter. Then draw lines to separate the words!

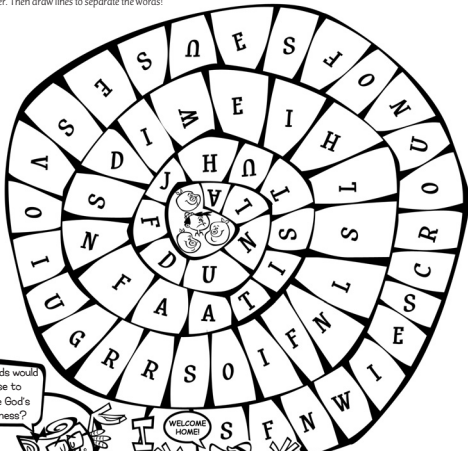

Write the collected letters below:
IF/WE/CONFESS/OUR
SINS/HE/IS/FAITHFUL
AND/JUST/AND/WILL
FORGIVE/US/OUR/SINS

RHYME TIME

Do each letter equation below. Then fill in the blanks in order to complete the poem!

- s+prince-pr = since
- valley-ley+ues = values
- eager-ger+child-ild = each
- helper-hel+son = person
- sea-a+e = see
- re+inspect-in+ful = respectful
- w+hat = what
- shoulder-er = should
- bee-e = be
- life-l-e = if
- gentleman-man = gentle



- kindergarten-ergarten = kind
- remind-re = mind
- fraction-r-ion = fact
- simple-sim+asked-k = pleased



Since God values each person we see,
respectful is what we should be.
if we're gentle and kind, God really won't mind—
In fact, He'll be pleased as can be!

RAINFOREST ROCKS!

1. Find the hidden animal names and write them in the puzzle.
2. Then write the circled letters in order in the blanks.
3. Read down the center column AND the blanks for an important message.

boa constrictor
chameleon
sloth
gecko
frog
bat
snake
grass
bromeliad
claiman
fish

What's a way you can serve others this week?

TO SERVE OTHERS!

FOLLOWING JESUS

by Joey Walker

I have decided to follow Jesus,
To go where He may go;
Now undivided, I live to worship;
My heart is His alone.
I will not cease to praise His name;
My life's been changed by His grace!

CHORUS:

I'm following Jesus (Hey! Hey! Hey!)
I'm following Jesus (Hey! Hey! Hey!)
I'm following Him today.
I'm following Jesus (Hey! Hey! Hey!)
I'm following Jesus (Hey! Hey! Hey!)
I'm following Him today.

I have decided to be His witness,
To take a stand for Him;
There's nothing better,
There's nothing greater
Than a life with Him.
I will not cease to praise His name;
My life's been changed by His grace!

REPEAT CHORUS

The cross before me,
The world behind me,
I fix my eyes on Him;
My Creator, my living Savior,
Forgiver of my sin.

The cross before me,
The world behind me,
I fix my eyes on Him;
My Creator, my living Savior,
Forgiver of my sin.

REPEAT CHORUS

I'm following Jesus (Hey! Hey! Hey!)
I'm following Jesus (Hey! Hey! Hey!)
I'm following Him today.

GOD GAVE JOHN 3:16

by Jamie Owens Collins

CHORUS:

**For God so loved the world
That He gave His one and only Son;
That whoever believes in Him
Shall not perish.**

**For God so loved the world
That He gave His one and only Son;
That whoever believes in Him
Shall not perish
But have eternal life.**

God gave because He loves us;
God gave His Son.
God gave because He loves us,
Loves us every one.

Jesus died and rose again
To lead us safely home again
And if we put our trust in Him
We will live forever.

REPEAT CHORUS

But have eternal life.

ALL OF THE TIME

by Judy and Marc Roth

CHORUS:

**You gotta trust (trust!), trust (trust!) in the Lord;
You gotta trust in the Lord with all of your heart.
You gotta trust (trust!), trust (trust!) in the Lord
And obey God all of the time.**

REPEAT CHORUS

God knows how the world works;
God knows what's best for you.
God knows where you're goin'
And He will help you through!

REPEAT CHORUS THREE TIMES

God knows how the world works;
God knows what's best for you.
God knows where you're goin'
And He will help you through!

REPEAT CHORUS

**And obey God all of the time.
And obey God all of the time.**

CALL UPON ME

by Judy and Marc Roth

CHORUS:

**“Call upon me and come and pray to me,
And I will listen to you.
Call upon me and come and pray to me,
And I will listen to you.”**

God will hear and answer you.
He loves you; He will listen to you.
God will hear and answer you.
He loves you; He will listen to you.
And God says,

REPEAT CHORUS

FORGIVING AND GOOD

by Mary Gross Davis and Lynnette Pennings

CHORUS:

**You are forgiving and good, O Lord,
Abounding in love to all who call to You, to all who call to You.**

**You are forgiving and good, O Lord,
Abounding in love to all who call to You, to all who call to You.**

Would You answer the phone? (Oh, no.)

Would You answer my e-mail? (No, no.)

Well, what should I say?

You just ask me to pray

When I call to You.

**You are forgiving and good, O Lord,
Abounding in love to all who call to You, to all who call to You.**

To all who call to You, to all who call to You.

GOD FORGIVES US

by Jamie Owens Collins

CHORUS:

**God forgives us when we do wrong, oh oh,
So we'll forgive each other,
God forgives us when we do wrong, oh oh,
So let's forgive each other, too.**

When a friend's unfair or doesn't seem to care,
When he makes a promise he won't keep,
When I'm feeling bad 'cause someone's made me mad,
I stop and think how God's forgiven me.

REPEAT CHORUS

People speak their minds with words that are unkind,
But we know there are times we've done the same,
So we will not react, or try to get them back.
Instead we will forgive in Jesus' name.

REPEAT CHORUS TWICE

LOVE NEVER FAILS

by Darla Plice

Love is patient, love is kind,

Love never fails.

It does not envy, it does not boast,

Love never fails.

It is not proud, it is not rude,

It is not self-seeking.

It is not easily angered; it keeps no record of wrongs.

CHORUS:

Love never fails.

Love never fails.

Love does not delight in evil, but rejoices with the truth.

It always protects, and always trusts,

Always hopes, always perseveres,

Love never fails.

Love never fails.

sALT

by Tim and Carla White

**You are the salt of the earth.
You are the salt of the earth.**

But if the salt loses its saltiness,
How can it be made salty again?
It is no longer good for anything,
Except to be thrown out and
trampled by men.

**You are the salt of the earth.
You are the light of the world.**

A city on a hill cannot be hidden.
Neither do people light a lamp
And put it under a bowl.
Instead they put it on its stand,
And it gives light to everyone in the house.

**You are the light of the world.
You are the light of the world.**

In the same way, let your light
shine before men,
That they may see your good
deeds and praise
Your Father in heaven.

**You are the salt of the earth.
You are the light of the world.
You are the salt of the earth.
You are the light of the world.**

Shine your light! Shine your light!

Wise Up!

by Jamie Owens Collins

Everybody knows what's wrong and right,
But knowing doesn't make you wise.
Wisdom lies in doing what you know is right
With strength that comes from Jesus Christ.

CHORUS:

Wise up!
Put your trust in the Lord.
Wise up!
Don't rely on your own
understanding.
Wise up!
Fill your heart with His Word
And you'll wise up.

Trusting in your feelings, that's not smart.
Feelings change from day to day.
But if you keep God's wisdom in your heart,
He will always lead the way.

REPEAT CHORUS

Put your trust in the Lord.
Wise up!
Don't rely on your own
understanding.
Wise up!
Fill your heart with His Word
And you'll wise up.
And you'll wise up.
And you'll wise up!